

*Lightalarms*

**Life safety equipment  
Emergency lighting systems**



**by ABB**

**Lightalarms**<sup>®</sup> is a life safety solutions provider, delivering state-of-the-art systems and products into the emergency lighting marketplace. Our products and services are designed to provide the most effective protection and safety, in line with customer needs, relevant industry standards and regulations.

# Table of contents

	Page		Page		Page
Company profile	2	<b>Battery Units</b>	<b>64</b>	<b>Battery packs</b>	<b>144</b>
Nexus® monitoring system	4	Table of contents	65	Table of contents	145
High output MR16 LED	6	Introduction	66	Introduction	146
LED emergency lighting	7	Hazardous Location Classifications	67	Ballast/ Lamp reference chart	147
Circuitry	8	Typical Class Locations & Nema Enclosures	68	LALDR Series	148
Popular options	9	Quick Reference Chart	69	LALDR CEC Series	150
<b>Exit Signs</b>	<b>10</b>	RP Series	70	LADL Series	152
Table of contents	11	LSCN Series	72	LADL 4 Pin Series	153
Introduction	12	Recessed mount Phantom™ Series	74	<b>Central &amp; Inverter Systems</b>	<b>154</b>
Quick Reference Chart	13	Recessed mount Mini-Phantom™ Series	76	Table of contents	155
Simplicity™ Premium SLED & SLED Series	14	Recessed mount TBR Series	78	EPC Fixture Mounted Series	156
6" Simplicity™ Accessibility Series	16	Recessed mount RD Series	80	EPC 2 Series	158
Simplicity™ Economizer SE, SES & SEN Series	18	Wall mount Protector™ Series	82	Mini Inverter Compatibility checklist	161
Simplicity™ Universal Edge-Lit Series	20	Surface mount LCAB-2SQLED Series	84	Low Capacity Mini Inverter Series	162
Simplicity™ Universal Combination Edge-Lit Series	22	Cluster™ LED LCA-2LEDR & ELF652D Remote	86	125W-720W Mini Inverter Series	164
Genesis™ Door/Floor Proximity Tandem Series	24	Surface mount Grande™ Compact Series	88	1000W Mini Inverter Series	166
Genesis™ GX & GXE Series	26	Surface mount Grande™ Series	90	Light Support Power Inverter Systems	168
Galaxy™ XD & XDN Series	28	Surface mount indoor Camray™ LED Series	92	Light Support Power Systems Compact Series	170
Galaxy™ XDPC Series	30	Surface mount MG/MN-SP Series	94	IPS Single Phase Series	172
Galaxy™ Slim TX & TXE Series	32	Surface mount MG & MN Series	96	FTC Single Phase Series	174
Galaxy™ XLD & XLED Series	33	Surface mount PG, PQ, P12G & P12Q Series	98	3FTC Three Phase Series	176
UX4 LED steel exit & combination Series	34	Surface mount S12E & S24E Series	100	FTC3R & 3FTC3R Series	178
Grande™ Exit Series	36	Surface mount Severe™ Series	102	Control Panel & Display Functions	180
Grande™ Combination Series	38	Surface mount SP Series	104	AC Central Systems Request Data	181
Quick™ QLX & QLXN Series	40	SPRL Series Surface mount Remote Fixture	106	<b>Accessories and General Information</b>	<b>182</b>
LAXC LED Series	42	Surface mount SPH Series	108	Table of contents	183
Square Head LED Combination Series & Remote	44	Surface mount SPHRL Remote Fixture Series	110	Lamp data	184
Cluster™ LED Round Head & ELF652D Remote	46	Surface mount Severe™ VH Series	112	Unit accessories	185
Severe™ XV & XVE Series	48	Surface mount EXP6N & EXP12N LED Series	114	Wire guards	186
Severe™ XV12E & XV24E Combination Series	50	LCA-2RHL Series	116	National Electrical Code	189
Severe™ XVHZ & XVEHZ Series	52	<b>Remote &amp; Heads</b>	<b>118</b>	Life Safety Code	193
Severe™ XVH & XVH12N Combo Series	54	Table of contents	119	Limited warranty	197
X402 AC-only, AC/DC & Self-Powered LED units	56	Introduction	120	Product index	198
EXP LED Series	58	RPR Series	122		
XT Tritium™ Self-Luminous Series	60	LSCN Series	124		
Special Wordings Series	62	Remote Fixture Decorative™ Series	126		
		Remote Fixture Phantom™ Series	128		
		Remote Fixture Saf-T-Ray™ Series	129		
		Remote Fixture Camray® LED Series	130		
		Remote Head & Unit Head DR Series	132		
		Remote Head and Unit Head ELF3 Series	133		
		LCARDSQLED Series	134		
		ELF612D/LED Series	135		
		Vandal-resistant ELF640 Series	136		
		NEMA-4X ELF650 Series	137		
		NEMA-4X SPRL Series	138		
		Hazardous location ELF651 Series	140		
		Hazardous location EPF401 LED Series	142		

# Depend on Lightalarms® for safety expertise

The experts at our state-of-the-art North American manufacturing center are at your service. The Lightalarms® Global Emergency Lighting Research & Innovation Center in Canada is part of the ABB Group, a pioneering technology leader.

Since 2001, the Thomas & Betts manufacturing facility has been ISO 1400 & OHSAS 18001 compliant.

## Highly skilled emergency lighting specialists

By partnering with Lightalarms®, you have access to our team of specialists with proven expertise in the emergency lighting industry. Our mechanical, electrical and software engineers and product designers work together under one roof. The team synergy and collaboration at our manufacturing center gives us unparalleled capabilities in design, innovation, quality, final assembly, testing, and service.

## Long-term reliability

Lightalarms® products are built to last, with quality, safety, reliability, and ease of installation built into each product from the earliest design stage. We use specialized quality inspection capabilities to perform functional testing on Lightalarms® products. By meeting high internal quality and performance standards at every step from design to production to order fulfillment, we ensure excellence.

## We are innovators and builders

As part of Thomas & Betts, a member of the ABB Group, our center of excellence benefits from frequent investment in the latest manufacturing technology. Automation is integrated throughout our manufacturing operations, optimizing efficiency to produce thousands of precision final assemblies each day.

## Custom, flexible solutions meet your specialized requirements

- Architectural
- Industrial
- Commercial

We have the design expertise and capacity to create solution-based products that meet your needs. Our experts take great pride in developing products that solve challenging problems.

## Fast delivery for express service

We keep ready-to-ship stock in warehouses across the U.S. for express service. As a North American manufacturer, we have complete control over lead time, quality, and service. Our manufacturing team of over 150 people is ready to produce exactly what you need without waiting for a large production run or overseas shipment.

## Energy-efficient, innovative solutions

The Lightalarms® product design team is at the forefront of new lighting design applications. We've expanded our capabilities to transform your existing lighting into emergency lighting with our newest high-capacity mini inverters. With the low energy requirements of our high-performance LED fixtures you can use fewer units to provide necessary illumination.

We put the power of automation in your hands with our Nexus® emergency lighting management system. From one central location, you can see the status of every unit at a glance.

## A partner you can trust

With Lightalarms®, you have

- Proven safety solutions
- A reliable business partner
- Industry experts
- Knowledgeable service
- North American manufacturing
- Peace of mind

To ensure your satisfaction, our knowledgeable North American service team works with you as your emergency lighting partners



The ABB North American facility is an emergency lighting center of excellence thanks to the commitment, expertise, and creativity of every employee.

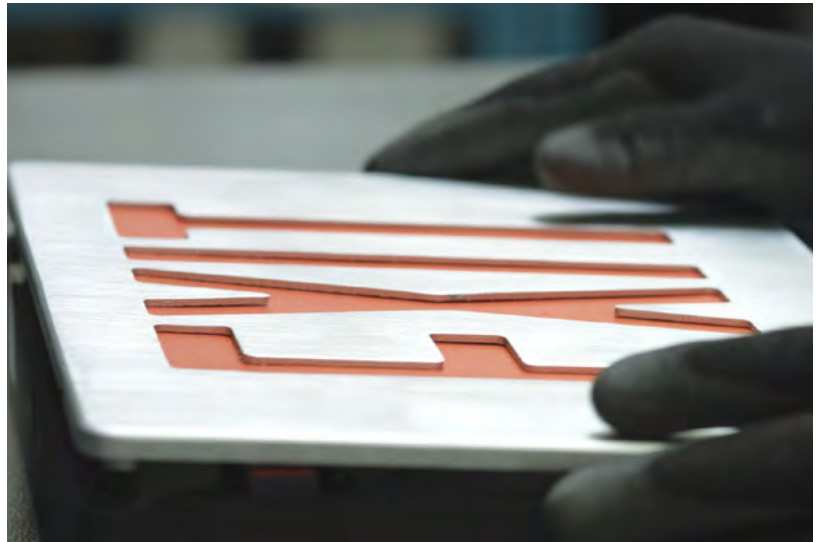
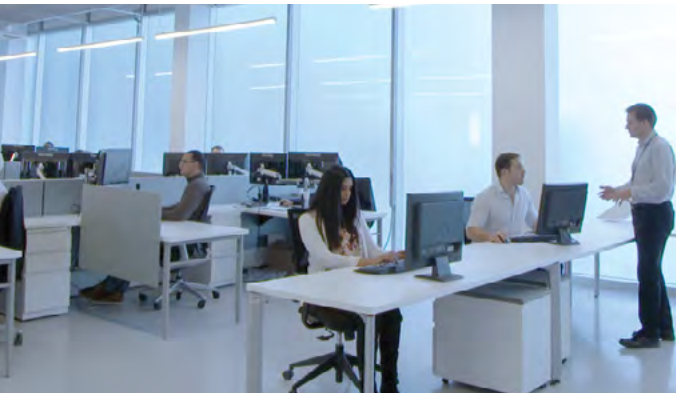

The new AOI (automated optical inspection) machine added to the ABB printed circuit board operation in 2012 is one of the first of its kind in use in North America.

# Nexus®

## Emergency lighting management system

Building & Life Safety Codes oblige building owners/ managers to ensure the safe evacuation of a building in the event of an emergency.

Nexus® is a proven system supported by a 5-year warranty, and can contribute to LEED certification and support green building initiatives.

### Are you prepared for a safety inspection?

In the interest of public safety, building owners/ managers must meet the outlined requirements for exit signs and emergency lighting equipment, including the following:

- Conduct a discharge test every month.
- Conduct functional tests annually.
- Keep a log book of maintenance information.

Complying with these requirements can be labor intensive and costly, especially in large buildings where testing every emergency light requires many man-hours. Disrupting the power supply during lengthy inspections can also put public safety at risk.

### Manage testing with Nexus® to save time and costs

Nexus® is a real-time monitoring system that manages the status of your entire emergency lighting and Exit Sign system from a central control unit. Nexus® runs diagnostics, performs required monthly and annual functional tests, generates maintenance logs and runs compliance reports. Available in wired or wireless (RF) versions, Nexus® installations often pay for themselves in less than two (2) years. In addition to operational savings, Nexus® helps increase system reliability and performance and reduces the risk of failed inspections. One building or a group of properties under the same management can be monitored with Nexus®.

### Maximize system availability

By allowing maintenance personnel to easily maintain and monitor the emergency lighting system without having to manually check each unit, Nexus® reduces the hours required to disrupt the power supply for inspections. With Nexus®, monthly tests and reports on the status of all emergency lights and exit signs can be done individually, in groups, or together.

Advantages of the Nexus® system include saving labor; maximizing system availability by testing units in groups and stages rather than setting all units in recovery mode; and the convenience of self-monitoring. Nexus® indicates the location of a faulty unit and reports it instantly without requiring a manual search.



One building or a group of properties under the same management can be monitored with Nexus®.

**Update Status Instantly**

Nexus® passes messages both to and from the emergency units to instruct the units to perform all mandatory testing by communicating between the emergency units and a centrally located controller. Nexus® is a proven system supported by a 5-year warranty, and can contribute to LEED certification and support green building initiatives.

As with the small system example, site performance will be optimized through the careful selection and placement of Area Controller Routers to form efficient clusters. Building layout and materials will also play some role in determining the best solution to deliver a highly effective means of testing and maintenance requirements.

**Small System Example**

In a system of less than 100 units it is most likely that the only hardware required, other than the emergency units themselves, is a controller. All communication would occur wirelessly and installation would not vary greatly from a nonmonitored system. Once the units are in place, the system will establish the mesh network. The building itself could be quite large as each unit only needs to be able to communicate with its close neighbors and does not need to communicate directly with the controller.

**Large System Example**

Nexus® is designed to enable building owners and managers to easily maintain and test emergency lighting, without the need to visually verify performance or disrupt the power supply.

With digital solutions, building owners now can have peace of mind knowing their buildings are safer than ever. All operations can be managed remotely, giving building owners and managers complete control wherever they are, whenever they need it most while preventing any human error in the process.

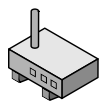
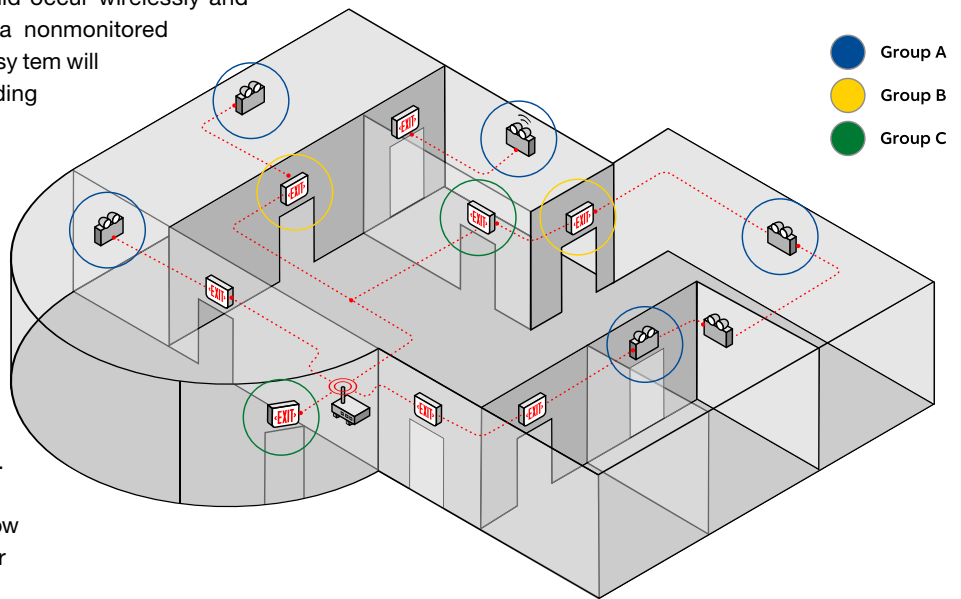

Area Controller Router



Radio Frequency (mesh network)



Exit Sign



Battery Unit

For Nexus® compatibility please refer to individual product pages for complete details.

# High output MR16 LED

## Emergency lighting

### MR16 LED Illumination

With the remarkable technology development in the last decade, the light-emitting diode (LED) is becoming the preferred solution in lighting applications. The emergency lighting industry is no exception: today virtually every new product introduced to market includes “white light” light LEDs for emergency illumination. Extremely efficient and long-lasting, LED lamps become the natural alternative to incandescent lamps due to three main advantages:

- Lamp efficacy: 50 - 100 lumen per watt compared to 15 - 30 lumen per watt for the best halogen lamp. Allowing for smaller batteries and units and/or remote capacity
- Operational life: 30,000+ hours, equivalent to a lifetime warranty in emergency lighting.
- Lower lamp temperature: (80 - 120°C) is a huge benefit for lighting in hazardous locations.

### MR16 LED Lamp Benefits

- Reduces total cost of ownership, uses few fixture due to superior illumination, thus reducing installations cost and future maintenance of the entire system.
- UL-recognized components.
- Available for standard battery voltages 6V, 12V and 24V as well as 120V operation.
- Energy-efficient LED MR16 lamp provides equivalent lighting performance to a much higher watt halogen MR16 lamp.
- Reduces required battery capacity by 75%, for battery units and remote heads.
- Small profile, compact white lighting is ideal for architectural applications.
- Typical 30,000 hours of operational life.
- Vibration-resistant LED stands up to industrial environments.
- Ideal for indoor and outdoor use.



#### 200-220-Lumen 4W MR16 LED

Leading the technology trend, **Lightalarms®** offers a complete series of 4W MR16 LED lamps available for all the standard battery voltages: 6V, 12V, 24V and 120V. With up to 30,000 hours of operational life and a luminous flux of typically 200 to 220 lumens, they are available with most emergency heads designed to hold an MR16 lamp and meet the majority of illumination specifications. For example: one pair of LED emergency heads installed at a height of 7.5ft illuminates a 6ft by 55ft path of egress.

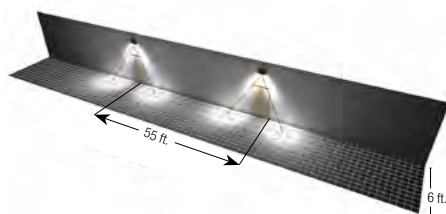

#### 55-ft. Path of egress 2 X 4W MR16 LED

Based on an average of 1 foot candle

#### 340-Lumen 5W MR16 LED

Keeping pace with technology, in 2012 we introduced a 12V-5W MR16 LED lamp. With a typical luminous flux of 340 lumens, this lamp has the same lighting performance as a 20W high-output halogen MR16. A twin emergency head installed at a height of 7.5ft illuminates 70ft path of egress. 6V-5W MR16 has been introduced in January 2020. A twin emergency head installed at a height of 7.5ft illuminates 70ft path of egress 70 ft.

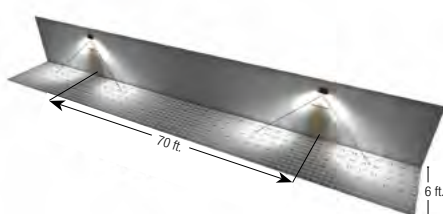

#### 70-ft. Path of egress 2 X 5W MR16 LED

Based on an average of 1 foot candle

#### 540-590 Lumen 6W MR16 LED

A 6W MR16 LED lamp delivers up to 590 lumens for an average spacing in emergency lighting of 106 feet with an efficacy of 98.3 Lm/w, it is over 6 times the efficacy of a MR16 35W halogen with similar light output. This lamp can deliver the highest linear foot of illumination per watt on a path of egress! (spacing in feet / watt) 8.83ft compare to 1.37ft for a MR16 35W.

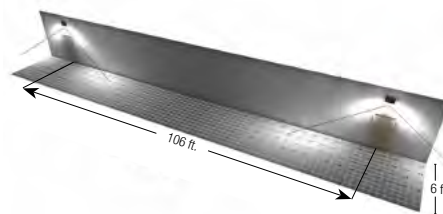

#### 106-ft. Path of egress 2 X 6W MR16 LED

Based on an average of 1 foot candle



## High output MR16 LED

### Emergency lighting

#### Case Study: Fewer MR16 LED units required

Emergency lighting units with MR16 LED lamps provide the same illumination at floor level using significantly less units.

- Reduced Installation Costs, less product needed and labor.
- Reduced Energy Costs, keeping batteries charged at full capacity to be ready to respond to an emergency situation at any time.

- Reduced Maintenance and Testing Cost, less units to maintain and test in the Emergency Lighting System.
- Reduced Lamp Replacement Cost, LED lamps have a 30,000+ hour lamp life compare to only a few hundred hour typical with incandescent lamps.
- Reduced Environmental impact, less product materials, less batteries, less transportation, less packaging, less labor, less waste.

#### Compare

Where the building code requires an average of 1 foot-candle and a minimum of 0.1 foot-candle at floor level along the path of egress on a 150' x 9' x 9' corridor with an egress door at one end, a 150' x 6' path of egress, and a 7.5' unit mounting height.

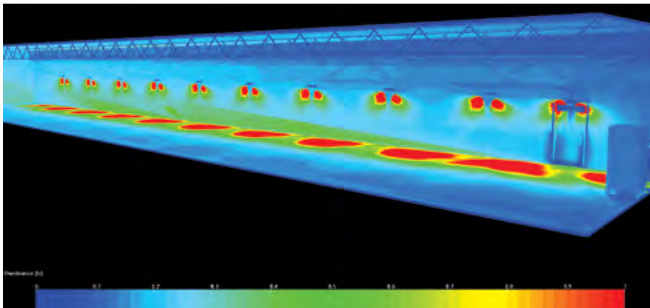

#### Standard wedge-base 9W Incandescent Lamp

Standard Emergency Lighting Units with 9W wedge-base incandescent lamps requires a total of 10 double-head units or remotes

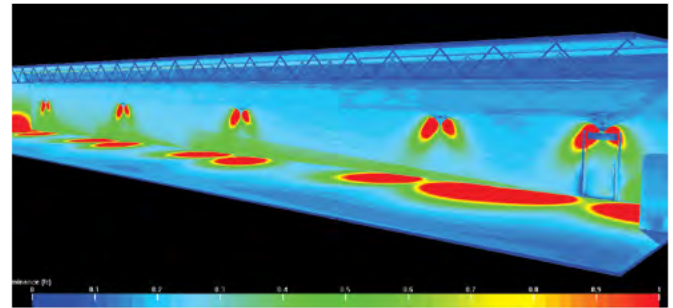

#### 4W MR16 LED lamps

Same Standard Emergency Lighting Units with 4W MR16 LED lamps requires a total of 5 double-head units or remotes.

MR 16 LED LAMPS				
Lamp suffix	Voltage	Wattage	Lumens	Replacement number
LD1	6	4	199	580.0097-L
LD7	12	4	220	580.0093-L
LD13	24	4	220	580.0098-L
LD25	120	4	204	580.0095-L

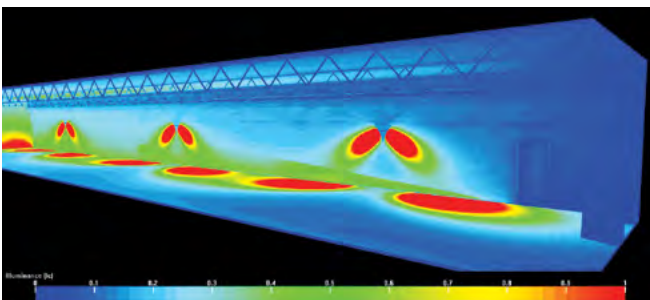

#### 5W MR16 LED lamps

Same Standard Emergency Lighting Units with 5W MR16 LED lamps requires a total of 3 double-head units or remotes

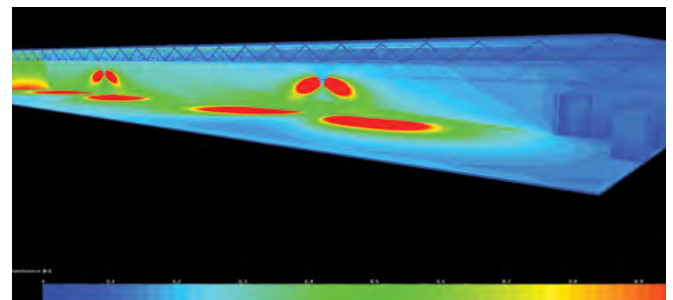

#### 6W MR16 LED lamps

Same Standard Emergency Lighting Units with 6W MR16 LED lamps requires a total of 2 double-head units or remotes

MR 16 LED LAMPS				
Lamp suffix	Voltage	Wattage	Lumens	Replacement number
LD2	6	5	415	580.0122-L
LD9	12	5	340	580.0104-L

MR 16 LED LAMPS				
Lamp suffix	Voltage	Wattage	Lumens	Replacement number
LD10	12	6	540	580.0106-L
LD14	24	6	590	580.0100-L

# Circuitry

## Emergency lighting

### Improved Diagnostics Circuitry

#### Self-Testing & Monitoring Diagnostic Circuitry

By incorporating diagnostics features with a high-powered 8-bit microcontroller, our Improved Diagnostics system ensures unsurpassed reliability in one, totally contained system. In the event of a unit malfunction, the Improved Diagnostics system produces an audible warning in the form of an intermittent beep and the LED indicator associated with the fault will illuminate continuously. When the problem is acknowledged by depressing the alarm/silence/test button, the alarm is silenced and the LED indicator changes to a flashing mode until the problem is corrected. Continually monitors system parameters

- Incorporates state-of-the-art microcontroller technology
- D includes audio and visual service alarms
- DNA non-audible version for visual service alarms only
- Self-testing in accordance with NFPA101, Life Safety Code minimum 30 seconds every 30 days, 30 minutes every six months and 90 minutes annually.

#### Features

##### Battery Failure

(Red) Illuminates if the battery is shorted or battery voltage drops below preset value. Will also detect incorrect battery (ie. 6VDC vs. 12VDC)

##### Battery Disconnect

(Red) Illuminates if the battery circuit is open.

##### Charger Failure

(Red) Illuminates when charger is not functioning properly by monitoring the charger current.

##### Lamp Failure

(Red) Illuminates when one or more emergency lamps fail. Also monitors remote lamps.

##### Service Alarm

(Red) Illuminates when a fault is detected that requires a qualified service technician.

##### AC-On

(Green) Lit when line voltage is present.

##### Charger On

(Amber) Illuminates when charger is recharging the battery.

##### Alarm Silence / Manual Test Switch

Button is used to acknowledge and silence audible alarms. Also functions as a manual test switch to simulate a power failure.

##### Self Testing

Unit tests itself every thirty days for a minimum 30 seconds, thirty minutes on the sixth month and ninety minutes annually.

#### To Order for Compatible Unit

**Add Suffix:** -ID (for audible circuit) to model number

**Add Suffix:** -IDNA (for non-audible circuit) to model number

Improved diagnostics (ID or IDNA) includes a Time Delay function, if needed it can be enabled/disabled in the field (15 min) or it can be preset at the factory by including the suffix ID-TD\* or IDNA-TD\*

### Pulse Type Circuitry

#### Prolongs the life of a battery through pulse charging

**Lightalarms®** PulseType circuitry utilizes the latest in solid state design to provide a technically advanced charger combined with features and functions that promote long reliable battery life and excellent unit performance.

The design of the PulseType circuit takes into account the long periods of inactivity typical of standby emergency equipment. Batteries are kept at full capacity by a pulse charge that allows the battery to cycle continuously. This greatly reduces the problem of grid corrosion and dramatically increases battery performance.

**Lightalarms®** computer-tests all active components on the circuit boards during assembly. Critical functions such as brownout, low voltage disconnect, and charge voltage are individually monitored and adjusted at the factory.

#### Features

##### 120/277V Input

Capability to operate with 120V or 277V input.

##### Fused Output Circuit for Units with Remote Capacity

Emergency units up to 54W have a single fused output circuit. Units over 54W have two fused output circuits supplied standard.

##### Dual Diagnostic Indicator Lights

Dual indicators, red and amber continuously monitor the condition of the battery, charge circuit and presence of AC.

##### Temperature Compensation

- At high ambient temperatures, batteries need less charge voltage to recharge.
- At low temperatures, batteries require a higher charge to maintain full capacity.
- The PulseType charger automatically adjusts the charge voltage to precisely what the batteries require at a given temperature.

##### Sealed Relay

- Sealed relay protects against environmental contaminants.
- Low Voltage Battery Disconnect
- The lighting load is disconnected from the battery at 87.5% of nominal battery voltage. This prevents deep discharge damage to the battery.

##### Brownout Protection

Emergency lamps energized when AC voltage falls to approx. 80% of nominal voltage, the level at which most fluorescent and HID fixtures extinguish.

##### Battery Lockout

This labor saving feature prevents the battery from discharging when the unit is installed to a non-energized circuit. The battery is electronically locked out until the unit is energized with AC power. Contractors do not have to return to a job site to connect batteries when the building's main power is turned on. They can install the unit and connect the battery in one convenient operation.

##### Reverse Polarity Protection

A polarized plug is used to connect the battery to the circuit board, thus preventing damage from occurring to the system.

##### Current Limited Output

Extends battery life by preventing overheating and battery gassing during recharge.

# Popular Options

## Emergency lighting

Lightalarms® Emergency Lighting Units and Exit Signs are available with a range of options that can be added to enhance performance, simplify testing or adapt emergency battery units or exit signs for use in specific environments. Please refer to individual product pages to verify availability of individual options on specific equipment.

### Dual Circuit (Exit Signs)

Option provides two AC input circuits to permit 2 separate AC sources to energize the sign.

**Add Suffix: -2**

### Tamper Proof/Vandal Resistant Screws

Tamper proof screws may be used on certain units to avoid unauthorized entry to circuitry or vandalism.

**Add Suffix: -VR**

### Lamp Disconnect Switch

Option will disconnect lamp load when area is not in use during prolonged power failure. The switch may also be used to reactivate emergency power to remote or unit heads.

**Add Suffix: -DS**

### Photocell Test Switch

Allows for testing of an emergency battery unit, a Self-Powered battery back-up exit sign or combination unit by means of illuminating, with a flashlight, a photocell mounted in the bottom of the fixture. For product compatibility please contact the factory.

**Add Suffix: -P or -PST depending on series**

### Flasher

The flasher option is used within Exit Signs to draw additional attention to the exit discharge area. When there is an emergency situation, the exit legend will illuminate as well as begin to flash thus drawing additional attention to the Exit Sign leading to a exit discharge.

**Add Suffix: -FL**

### Flasher/Buzzer

The flasher/buzzer option is used within Exit Signs to draw additional attention to the exit discharge area. When there is an emergency situation, the exit legend will illuminate as well as begin to flash and admit an audible buzzer thus drawing additional attention to the Exit Sign leading to a exit discharge.

**Add Suffix: -FB**

### Fire Alarm Activated Flasher

Fire Alarm Activated Flasher option is for an Exit Sign that is wired into the Fire Alarm system of a building via 24 volt wire. When the fire alarm is activated the exit legend will flash to draw additional attention to the exit discharge area. This flashing option will only activate when the fire system is activated.

**Add Suffix: -FAF**

### Fire Alarm activated Flasher/Buzzer

Fire Alarm activated Flasher/Buzzer option is for an Exit Sign that is wired into the Fire Alarm system of a building via 24 volt wire. When the fire alarm is activated, the exit legend will flash and the Exit Sign will buzz to draw additional attention to the exit discharge area. This option will only activate when the fire system is activated.

**Add Suffix: -FBF**

### Time Delay

Option is designed to be used in areas where HID type lamps are used for normal lighting. As these lamps require several minutes to re-strike and to produce their nominal lighting output, it is necessary to also hold the emergency lighting on for this period, even after the AC utility has been restored. A time delay unit can be helpful in areas where it is difficult to directly access an emergency lighting unit's test switch. The power to the unit can be briefly switched off and on at the breaker panel, and the maintenance person can then return to the unit and observe a timed emergency operation.

**Add Suffix: -T3 (15 minutes)**

### Damp Location

Option for environments that are subject to moderate amounts of moisture (humidity), and a temperature range between 10°C (50°F) and 40°C (104°F). Example: partially protected exterior areas such as canopies, stairwells, etc.

**Add Suffix: -DL**

### Improved Diagnostic Circuitry (for exit signs)

Option is designed to continuously monitor the charger assembly, battery and LED assembly current. If a fault is indicated, the external service required indicator will illuminate. The diagnostic/self test will self test for minimum 30 seconds every 30 days, 30 minutes every six months and 90 minutes annually. Meets NFPA 101 Life Safety Code requirements for periodic testing.

**Improved Diagnostic (Audible) Add Suffix: -ID, -DA**

**Improved Diagnostic (Non-Audible) Add Suffix: -IDNA, -D**

### Improved Diagnostic Circuitry (for battery units)

**Improved Diagnostic (Audible) Add Suffix: -ID**

**Improved Diagnostic (Non-Audible) Add Suffix: -IDNA**

For complete Improved diagnostic circuitry details, refer to page 8.























#### EXIT SIGNS SERIES

Exit signs are required in every type of environment. Lightalarms® manufactures exit signs to meet the requirements of most environments and applications.

# Table of contents

## Exit & Combination Unit Series

					
Introduction About exit signs & reference chart	Architectural Simplicity™ Premium SLED & SPLED Series	Commercial 6" Simplicity™ Accessibility Series	Commercial Simplicity™ Economizer SE, SES & SEN Series	Commercial Simplicity™ Universal Series	Commercial 6" Combo Edge-Lit Series
12-13	14-15	16-17	18-19	20-21	22-23
					
Architectural Genesis™ "Over The Door & Floor Proximity" Tandem Series	Architectural Genesis™ GX & GXE Series	Commercial Galaxy™ XD & XDN Series	Commercial Galaxy™ XDPC Series	Commercial Galaxy™ Slim TX & TXE Series	Commercial Galaxy™ XLD & XLED Series
24-25	26-27	28-29	30-31	32	33
					
Commercial UX4 LED steel exit & combination Series	Architectural Grande™ Exit Series	Architectural Grande™ Combination Series	Commercial Quick™ QLX & QLXN Series	Commercial LAXC LED Series	Commercial Square Head LED Combination Series & Remote head
34-35	36-37	38-39	40-41	42-43	44-45
					
Commercial Cluster™ LED Round Head UQLXN500 & ELF652D Remote Head Series	Industrial NEMA-4X Severe™ XV & XVE Series	Industrial NEMA-4X Severe™ XV12E & XV24E Combination Series	Industrial Class I, Division 2 Severe™ XVHZ & XVEHZ Series	Industrial Class I, Division 2 Severe™ XVH, XVH12N & XVH12H Combination Series	Industrial Class I, Division 1 & 2 Class II, Division 1 & 2 X402 AC-ONLY, AC/DC & Self-Powered LED exit sign & combination units
46-47	48-49	50-51	52-53	54-55	56-57
					
Industrial Class I, Division 1 & 2 Class II, Division 1 & 2 EXP6N & EXP12N LED Series	Industrial XT Tritium™ Self-Luminous Series	Commercial Special Wording Series			
58-59	60-61	62-63			

# About Exit Signs

Unlike battery units, exit signs must be illuminated at all times, 24 hours, 7 days a week, during normal operation. During an emergency operation situation, such as a loss of AC power, the exit sign must be illuminated for a minimum of 90 minutes.

## Legend

An exit sign legend is defined as a single word "EXIT" with chevron indicators to direct occupants of a building to the nearest exiting point of that building. Legends are required to meet visibility, brightness, uniformity, and lettering/background contrast maximum to minimum ratios. Legend standards require EXIT lettering dimensions to be a minimum of 6" high with a 3/4" stroke, and chevron indicators that are visible at 50 feet. Exit legends are available in red or green as required by local code requirements.

## Illumination

The most popular light source to illuminate an exit sign is Light Emitting Diodes (LED) which all our Exit signs offer. We use red or green long-life, energy-efficient LEDs. LEDs are very energy efficient, limiting the energy each exit sign uses 24 hours a days, 7 days a week. The long life limits the maintenance required to replace lamps. There are two different methods typically used to illuminate an EXIT legend. The most common method is found in back-lit signs, which use an LED light source located behind the legend, illuminating through a red or green diffuser. The edgelit method uses a clear, white or mirrored acrylic face panel on which the legend is etched or silk-screened, and the LED light source is installed in the Exit Sign housing along the top edge of the panel, allowing the light to travel through the acrylic to illuminate the etched or a silk-screened legend. In general, back-lit exit signs are more economical and acrylic edge-lit exit signs are more high-end, elegant fixtures.

## Operational types

There are typically 3 types of exit sign designs, AC-Only, AC/DC and Self-powered that ensure that an Exit sign will work under normal operation conditions and in emergency operation mode.

An AC-Only exit sign is illuminated under normal operation conditions by the AC utility power supplied to a building; emergency operation mode power is supplied by an AC inverter or generator.

An AC/DC exit sign is illuminated under normal operation by the AC utility power supplied to a building; emergency operation power is supplied by a DC power source, such as a battery unit with extra battery capacity to ensure that both the exit sign and the battery unit will run for 90 minutes.

A Self-powered or battery back-up exit sign is illuminated under normal operation by the AC utility power supplied to a building; emergency operation power is supplied by a battery contained inside the exit sign housing, providing illumination for a minimum of 90 minutes. A Combination Unit is also self-contained and commonly includes an exit sign and a two-headed battery unit combined into one unit. The exit sign is illuminated under normal operation, while the two heads only illuminate during emergency operation mode.

## Environments

For vandal-resistant applications, standard exit signs can be made vandal resistant by using polycarbonate shields and/or tamper resistant screws, or a vandal-resistant exit sign such as the Severe™ Family Exit Series can be used. A damp location is an area that is indirectly subjected to moisture and typically uncontrolled temperatures, for example in a courtyard under an eave. NEMA-4X-rated exit signs are designed for harsh or corrosive environments where oil-, water-, and dust-tight construction is required. There are different NEMA ratings based on the application environment. Hazardous Location-rated equipment must be a type which will NOT itself contribute to the ignition of flammable or explosive substances present in the location of the emergency lighting unit. Hazardous locations include oil refineries, paint shops, dry cleaning plants, textile mills etc. Hazardous location-rated equipment is divided into different Classes and Groups, depending on the specific gases or chemicals present.

## Options

Besides offering many different types of exit sign housings for various environments Lightalarms® also provides a wide choice of options to meet specific customer requirements. Self-Diagnostic/Self-test features are designed to continuously monitor every critical function of the exit sign, battery, charger, LED lamps and lamp heads supplied with a combination Unit to ensure that the unit is working properly and is ready for an emergency situation. The flasher option allows the exit panel to flash to indicate that there is an emergency situation, thus drawing attention to the exit. The flasher/buzzer option allows the exit panel to flash and sound a buzzer to indicate that there is an emergency situation, thus drawing attention to the exit. A Fire Alarm activated flasher/buzzer is connected to a fire alarm system via a 24V wire and will cause the exit sign panel to flash and sound a buzzer when a fire alarm is activated.

The Dual circuit feature allows input from a utility AC source as well as a secondary utility AC source. The Time Delay feature allows a Combination Unit to stay illuminated after the AC power is restored thus allowing HID lamps that may need re-striking to reach full illumination before returning to normal operation. Damp location operation is for exit signs that will be subjected to slight moisture and typically uncontrolled temperatures. The Cold Weather option allows the batteries inside of an exit sign to maintain an optimal temperature range to work properly to provide emergency back-up operation. Vandal-resistant screws and polycarbonate shields provide extra protection in areas where the exit sign may be subject to vandalism.

# Exit Signs Series

## Quick reference chart

Product description	Simplicity™ Premium Series	Simplicity™ Accessibility Sign	Simplicity™ Economizer Series	Simplicity™ Universal Series	Genesis™ Floor Proximity Series	Genesis™ GX, GXE Series	Galaxy™ XD, XDN Series	Galaxy™ XDPC Series	Galaxy™ Slim Series	Galaxy™ XLD & XLED Series	Ux4 Led Series	Grande™ Series	Grande™ Combination Series	Quick™ QLX, QLXN Series	LAXC LED Series	Square Head LED Combo Series	Cluster LED Round Head & ELF652D	Severe™ XV Series	Severe™ XV Combination Series	Severe™ XHZ Series	Severe™ XVH Combo Series	X402 AC-only AC/DC	EXP LED Series	XT Tritium™	
<b>Application</b>																									
Architectural	+				+	+						+	+												
Commercial		+	+	+			+	+	+	+	+			+	+	+	+								
Industrial																		+	+	+	+	+	+	+	
Remote capacity											+		+						+		+		+		
Damp listed						+	+	+	+			+	+	+				+	+						
NEMA 4X																		+	+						
Hazardous locations																				+	+	+	+	+	+
<b>Housing</b>																									
Aluminum	+	+	+	+	+	+	+	+	+	+													+	+	+
Thermoplastic												+	+	+	+	+	+				+			+	
Steel											+														
Polyvinyl chloride																		+	+	+					
<b>Exit legend</b>																									
6 inch letters	+	+	+	+	+	+	+	+	+	+	+	+	+	+	+	+	+	+	+	+	+	+	+	+	+
8 inch letters	+		+			+																			
<b>Color</b>																									
White	+	+	+		+	+	+	+	+	+	+	+	+	+	+	+	+	+	+						+
Black	+				+	+	+	+	+	+	+	+	+				+	+	+						+
Aluminum body or face	+	+	+	+	+	+	+	+	+	+	+	+	+					+	+						
Gray																		+	+	+	+	+	+		
Custom	+					+																			
<b>Illumination</b>																									
Red LED	+	+	+	+	+	+	+	+	+	+	+	+	+	+	+	+	+	+	+	+	+	+	+	+	+
Green LED	+		+	+	+	+	+	+	+	+	+	+	+	+	+	+	+	+	+	+	+	+	+	+	+
Self-luminous tritium																									+
<b>Available options</b>																									
Self-diagnostic	+			+		+	+	+		+	+	+	+		+	+	+	+	+	+	+	+	+	+	+
Flasher/Buzzer	+					+	+	+		+	+	+	+					+	+						
Fire alarm active flasher	+					+	+	+		+	+	+	+					+	+						
Dual circuit	+				+	+	+			+	+	+	+					+							
Time delay								+					+												
Cold weather																		+	+	+					
Vandal resistant screws						+	+	+		+	+	+						+	+	+					
Vandal resistant screws & face plate					+	+	+	+		+	+	+													
SPECIAL WORDING	+		+			+	+	+		+	+	+						+	+	+	+	+	+	+	+
<b>Accessories</b>																									
Pendant mount	+	+		+		+	+				+		+			+	+	+	+	+	+	+	+	+	+
Wire guard - (wall)						+		+		+	+	+		+	+	+	+								
Wire guard - (ceiling)						+		+		+	+			+	+										
Wire guard - (end)						+				+	+			+	+										
Vandal resistant shield - (wall)					+	+						+	+												
Vandal resistant 4X shield - (wall)						+																			
<b>Origin</b>																									
North America	+		+		+	+	+				+	+	+					+	+	+	+	+	+	+	+

NOTE: This is a quick reference guide only. Refer to individual product pages for complete details regarding applicable models.

## Simplicity™ Premium SLED & SPLED Series

Premium die-cast aluminum and laser-etched acrylic edge-lit exit sign



### Construction

- Universal mount housing models use (D) dome and (P) pyramid, trim plate, trim ring and canopy made of die-cast aluminum
- Fully recessed only mount housing with (Z) flat trim plate includes steel back-box and hanger bars
- U-shaped clear acrylic legend panel features laser-etched letters and chevrons
- 6 inch EXIT lettering legend, available in red or green
- 8 inch EXIT lettering legend, available in red
- Choice of finishes: white, black or brushed aluminum, dark bronze, polished brass, polished chrome and painted

### Mounting

- (D) Dome and (P) pyramid trim models modular design allows for surface, wall, end or ceiling mount, as well as, recessed wall or ceiling applications
- (D) Dome and (P) pyramid trim models include a canopy for surface wall, end or ceiling mount and for recessed wall or ceiling applications a trim ring and hanger bars for installation into t-bar grid
- (D) Dome and (P) pyramid trim models housing is brushed aluminum with conduit knock-out 1/2", top back and end
- (Z) Flat trim models are for RECESS MOUNTING ONLY and can not be used for surface mount applications
- (Z) Flat trim models include a unfinished steel back-box and hanger bars for installation into ceiling and t-bar grid

### Housing color



Brushed aluminum

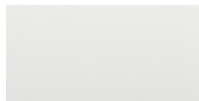

White



Black

Dark bronze  
(painted)

Polished brass



Polished chrome

### Chevrons

Chevron  
right (R)  
single faceChevron  
left (L)  
single faceSingle face, double  
chevron (1D) double face,  
double chevron (2D)Double face, single chevron (RL)  
represents each side of a double  
face panel.

### Special wording panels

Available. Contact your sales representative with your design requirements

### Electronics

- Optional Improved Diagnostics
- Optional Nexus® monitoring system
- 120-277 60Hz

### Approvals

- UL 924 listed
- Meets NFPA101 (Life Safety Code), NFPA 70 NEC, OSHA illumination standards
- ROHS compliant
- E-California Energy Commission Title 20

**Warranty** (subject to proper installation and maintenance)

Unit has a Five-year limited warranty

Detailed warranty terms located on **page 197** or online at: [www.lightalarms.com](http://www.lightalarms.com)



nexus



### Trim plates



(D) Dome Trim Plate



(P) Pyramid Trim Plate



(Z) Flat Trim

(D) Dome Trim Plate and (P) Pyramid Trim Plate photo/text  
(D) & (P) trims used with universal surface and recess mount  
housing models

For recess mount  
applications ONLY  
(housing is not universal)



**Dimensions** (Dimensions are approximate and subject to change):

**Mounting applications available with dome (D) and pyramid (P) trim plates**

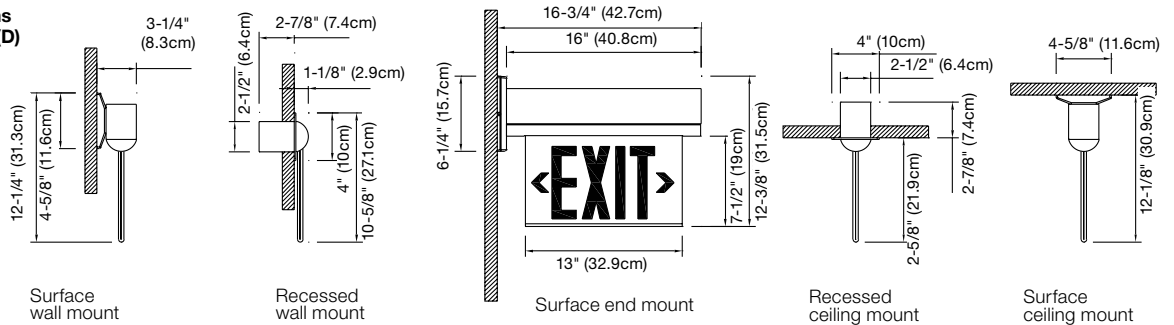

**Mounting application available with flat (Z) trim plate - recessed ceiling mount only**

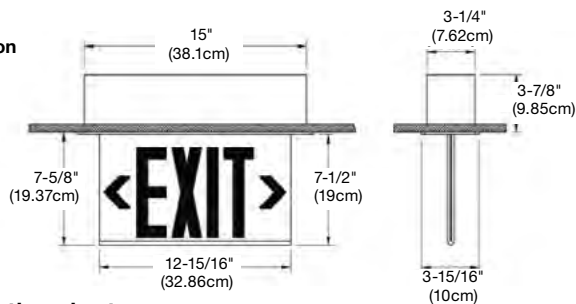

**When using (D) Dome Trim or (P) pyramid models:**

For Recessed mount, use these components

For Surface mount, use these components

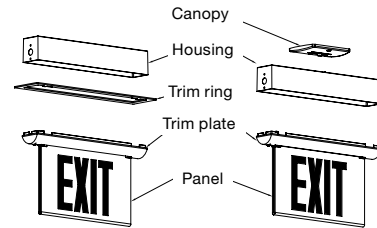

**Power consumption chart**

Model	AC Specs	DC Specs
AC-Only	120-277VAC, 60Hz (Less than 1.4W)	-
AC/DC	120-277VAC, 60Hz (Less than 1.4W)	6 to 24VDC (Less than 1.4W)
Self-powered	120-277VAC, 60Hz (Less than 2.3W)	Nickel-Cadmium battery (Min. 90 minutes)
Self-powered diagnostic	120-277VAC, 60Hz (Less than 2.3W)	Nickel-Cadmium battery (Min. 90 minutes)

**Accessories** (Order as a separate item)

Product code	Description
PW-*	Pendant, white
PB-*	Pendant, black
PA-*	Pendant, gray

\* Specify pendant length (12", 24", 36", etc).

**Ordering format**

Legend	Series	Housing color	Legend color	Panel background color	Trim plate	Chevron	Charger type	Options
<b>Blank</b> = 6" EXIT legend	<b>SLEDN</b> = AC-only	<b>A</b> = Brushed aluminum	<b>R</b> = Red	<b>C</b> = Clear (single face only)	<b>D</b> = Dome <sup>2</sup>	<b>Blank</b> = No chevron (single face sign)	<b>Blank</b> = AC only	<b>Blank</b> = No option
<b>8</b> = 8" EXIT legend	<b>SPLEDN</b> = Self-powered	<b>W</b> = White	<b>G</b> = Green	<b>W</b> = White (single or double face)	<b>P</b> = Pyramid <sup>2</sup>	<b>2</b> = No chevron (double face sign)	<b>-DC</b> = AC/DC model 6 to 24VDC	<b>-FAF</b> = Fire alarm flasher (SP only)
		<b>B</b> = Black		<b>M</b> = Mirror (single or double face)	<b>Z</b> = Flat trim <sup>3</sup>	<b>L</b> = Left chevron (on a single face sign)	<b>-ID</b> = Self-test and diagnostic (SP only)	<b>-FB</b> = Flasher & buzzer (SP only)
		<b>DB</b> = Dark bronze (painted)				<b>R</b> = Right chevron (on a single face sign)	<b>-NEX</b> = Nexus <sup>®</sup> Wired <sup>1</sup>	<b>-LP</b> = Panel shipped separately
		<b>PB</b> = Polished brass				<b>RL</b> = Left & right chevron (double face sign, one chevron on each side)	<b>-NEXRF</b> = Nexus <sup>®</sup> Wireless <sup>1</sup>	<b>-X</b> = Back box shipped separate
		<b>CH</b> = Polished chrome				<b>1D</b> = Double chevron (on single face)	<b>-Y</b> = Two circuits (AC only)	
						<b>2D</b> = Double chevron (double face sign, two chevrons on each side)		
						<b>UA</b> = Single face with universal stick on chevrons (2 Qty)		
						<b>2UA</b> = Double face with universal stick on chevrons (4 Qty)		

**Example: SLEDNARWDLY**

<sup>1</sup> Consult your sales representative.

<sup>2</sup> Universal housing for Surface or Recessed mount applications

<sup>3</sup> Fully Recessed ONLY applications (not to be used for surface mount)

## 6" Simplicity™ Accessibility Series

Slim profile LED edge-Lit exit accessibility sign



### Construction

- Housing made of extruded aluminum, canopy made of die-cast aluminum
- Legend panel features a curved contour for maximum illumination and clarity
- 6 inch EXIT lettering legend available in red with accessibility symbol
- Choice of housing and trim plate finishes, off white or textured aluminum
- Universal field selectable chevrons

### Mounting

- Canopy included for wall, end or ceiling mount applications

### Special Wording Panels

Available. Contact your sales representative with your design requirements

### Approvals

- UL 924 listed
- RoHs compliant
- Connecticut State Fire Safety Code

### PARA 1011.1.2

1011.1.2 Accessible exits. Where exit signs are required by Section 1011.1 of this code, accessible exit doors at the level of exit discharge that lead directly to accessible paths of exit discharge shall additionally be marked by the International Symbol of Accessibility. Such symbol shall be not less than 6 inches high and shall be incorporated into the required exit sign or shall be located directly adjacent to it. Such symbol shall meet the requirements of Section 1011.

**Warranty** (subject to proper installation and maintenance)

Five-year limited warranty

Detailed warranty terms located on **page 197** or online at: [www.lightalarms.com](http://www.lightalarms.com)



### Housing color



Textured aluminum

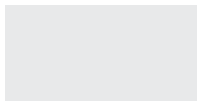

Off white

**Dimensions** (Dimensions are approximate and subject to change):

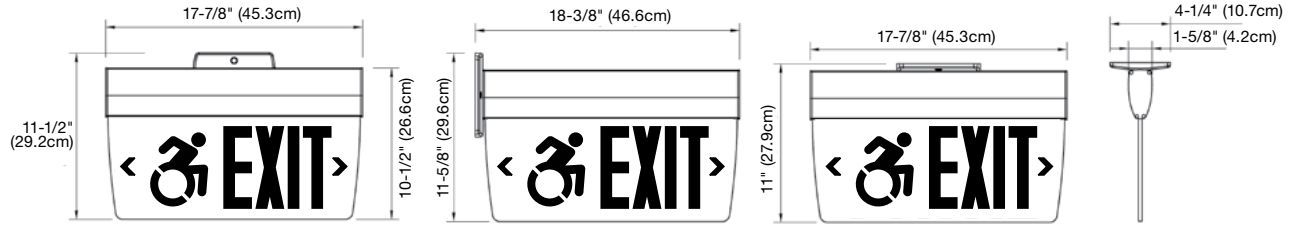

**Panel configuration**

**Symbol left**

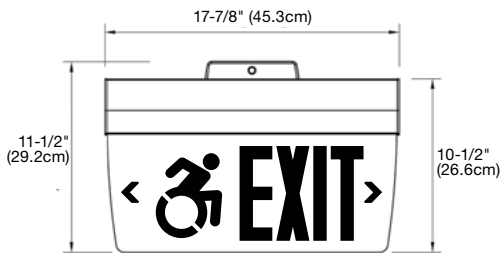

**Symbol right**

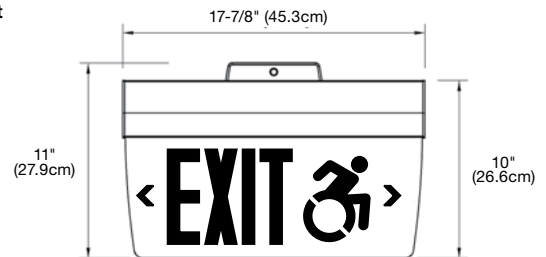

**Power consumption chart**

Model	AC Specs	DC Specs
AC-Only	120/277VAC, 50/60Hz (Less than 2W)	-
AC/DC	120/277VAC, 50/60Hz (Less than 2W)	6 to 24VDC (Less than 1.5W)
Self-powered	120/277VAC, 50/60Hz (Less than 3W)	Ni-Cd battery (Min. 90 minutes)

**Ordering format**

Panel configuration	Series	Housing color	Legend color	Face
<b>RISA</b> = Right side, 6" letters & International Symbol of Accessibility <sup>1</sup>	<b>SE</b> = AC Only <b>SES</b> = AC/DC	<b>TA</b> = Textured aluminum <b>OW</b> = Off White	<b>RC</b> = Red on clear <sup>2</sup> <b>RW</b> = Red on white <b>RM</b> = Red on mirror	<b>1</b> = Single face <b>2</b> = Double face
<b>LISA</b> = Left side, 6" letters & International Symbol of Accessibility <sup>1</sup>	<b>SEN</b> = Self-powered 90 Minutes			

**Example: LISASENTARW2**

<sup>1</sup> Red legend / surface mount only

<sup>2</sup> Single face Only

## Simplicity™ Economizer SE, SES & SEN Series

Surface or recessed mount edge-lit exit sign



### Construction

- Recessed model steel housing with extruded aluminum trim plate
- Surface mount model extruded aluminum housing
- Panel features a curved contour for maximum illumination and clarity
- 6 inch EXIT lettering legend available in red or green
- 8 inch EXIT lettering legend available in red
- Choice of housing and trim plate finishes, off white or textured aluminum
- Universal field selectable chevrons

### Mounting

- Recessed model: Fully recessed ceiling mount
- Recessed model includes hanger bars for lay-in installation in T-bar grid
- Surface mount model includes canopy for ceiling, wall or end mount

### Special Wording Panels

Available. Contact your sales representative with your design requirement

### Electronics

120/277 60Hz

### Approvals

- UL 924 Listed
- Meets NFPA101 (Life Safety Code), NFPA 70 NEC, OSHA illumination standards
- E-California Energy Commission Title 20

**Warranty** (subject to proper installation and maintenance)

Five-year limited warranty

Detailed warranty terms located on **page 197** or online at: [www.lightalarms.com](http://www.lightalarms.com)



### Housing color



Textured aluminum

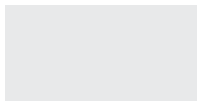

Off white

**Dimensions** (Dimensions are approximate and subject to change):

**Surface mount**

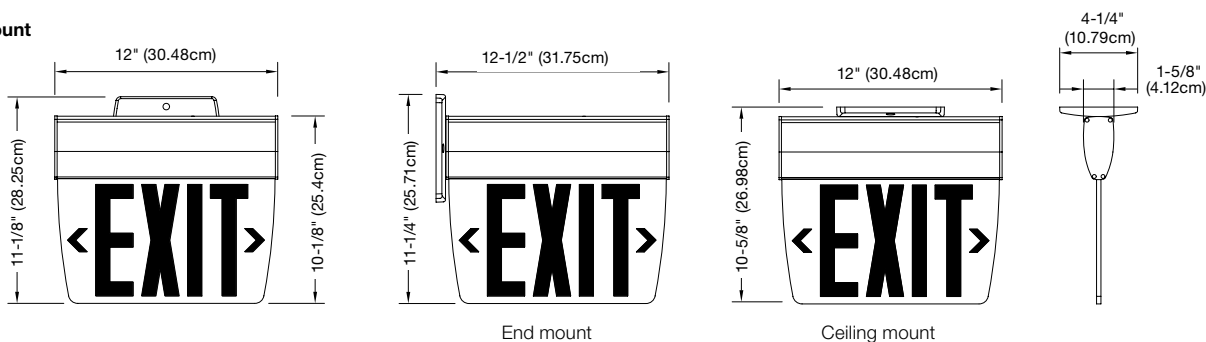

**Recessed ceiling mount only (F) flat trim plate**

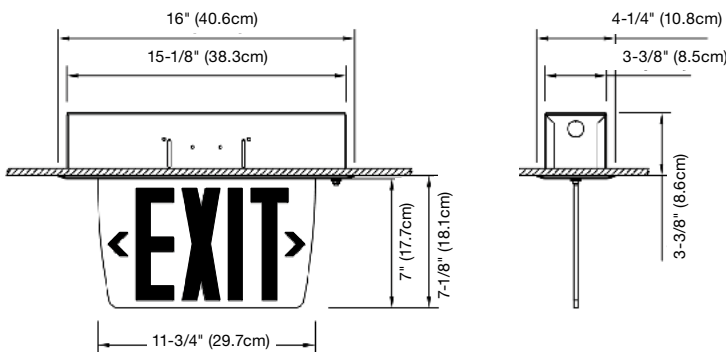

**Power consumption chart**

Model	AC Specs	DC Specs
AC-Only	120-277VAC, 50/60Hz (Less than 2W)	-
AC/DC	120-277VAC, 50/60Hz (Less than 2W)	6 to 24VDC (Less than 1.5W)
Self-powered	120-277VAC, 50/60Hz (Less than 3W)	Ni-Cd (Min. 90 mins)

**Ordering format**

6 inch Series	Trim	Housing color	Legend color	Face
SE = AC-only SES = AC/DC SEN = Self-powered	Blank = Surface mount only F = Recessed mount only (flat trim)	TA = Textured aluminum OW = Off white	RC = Red on clear <sup>1</sup> RW = Red on white RM = Red on mirror GC = Green on clear <sup>2</sup> GM = Green on mirror	1 = Single face 2 = Double face
<b>Example: SEFOWRC1</b>				

<sup>1</sup> Single face only.

<sup>2</sup> Green on white not available.

8 inch Series	Trim	Housing color	Legend color	Face
8SE = AC-only 8SES = AC/DC 8SEN = Self-powered	Blank = Surface mount	TA = Textured aluminum OW = Off white	RC = Red on clear <sup>1</sup> RW = Red on white RM = Red on mirror	1 = Single face 2 = Double face

<sup>1</sup> Single face only. Green not available in 8".

**Example: 8SEFOWRC1**

## Simplicity™ Universal Edge-Lit Series

Single and double face, surface and recessed\* mount edge-lit exit sign



### Construction

- High grade acrylic panel
- 6 inch EXIT lettering legend, available in red or green
- Field-selectable chevrons
- Satin aluminum housing

### Mounting

- Universal mount model
- Double face acrylic panel with mirror background, field adaptable for single face
- Pivoting panel design allows for recessed, surface, wall or ceiling mount installation
- A ratcheting mechanism allows the panel to be set in place from 0° to 180° for wall or sloped ceiling mounting
- Canopy included for surface wall, end or ceiling mount application
- Trim plate, 27 inch adjustable T-bar hangers and a junction box included for recessed\* application

\* Not intended for closed ceilings such as plaster and sheetrock.

### Electronics

Compatible with Lightalarms Mini Inverters (contact your sales representative for more information)

### Approvals

- UL 924 listed
- Damp location 50°F to 104°F (10°C to 40°C)
- Meets, NFPA101, (Life Safety Code) NFPA 70-NEC and OSHA illumination Standards

**Warranty** (subject to proper installation and maintenance)

Three-year full warranty

Detailed warranty terms located on **page 197** or **online at: [www.lightalarms.com](http://www.lightalarms.com)**



**Dimensions** (Dimensions are approximate and subject to change):

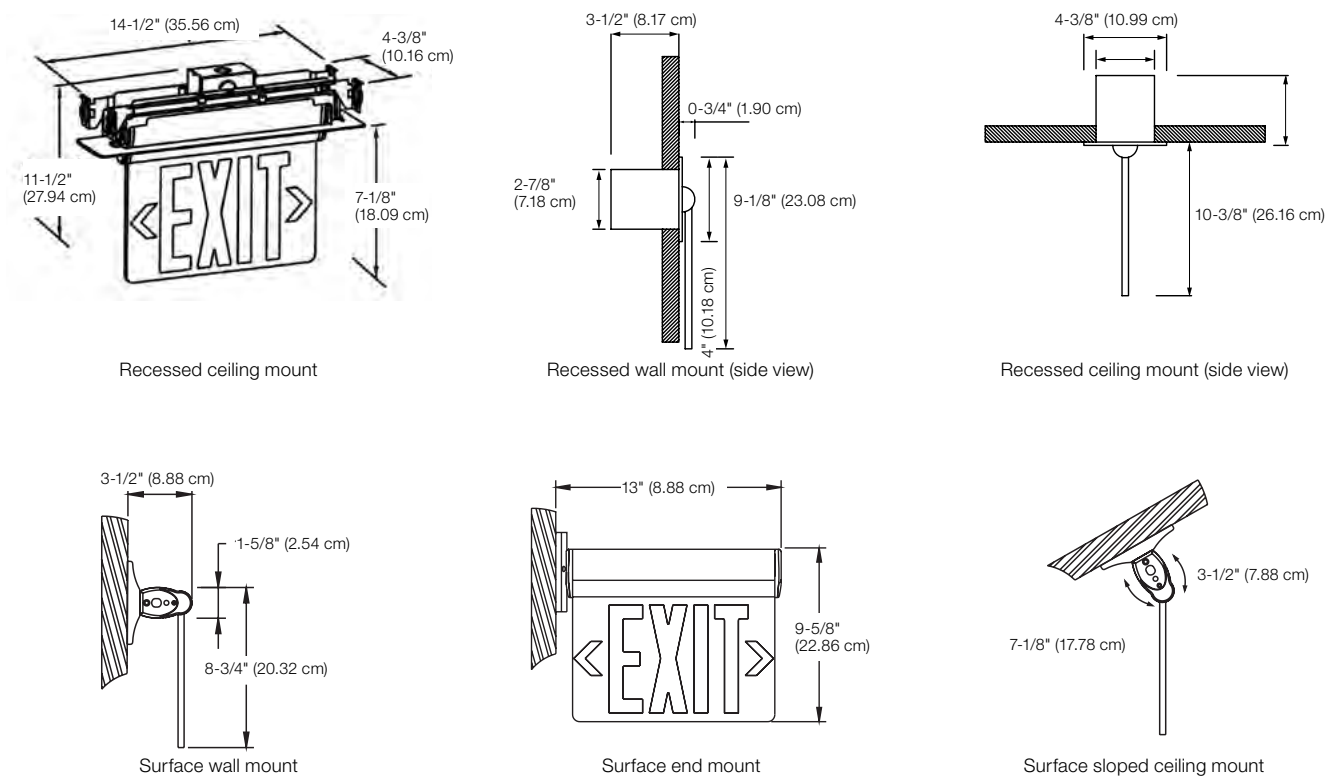

**Power consumption chart**

Model		AC Specs	DC Specs
Red	AC-Only	120VAC, 60Hz (2.0-2.6W)	-
		277VAC, 60Hz (2.6-3.1W)	-
	Self-powered	120VAC, 60Hz (2.0-2.6W)	Ni-Cd battery (Min. 90 Minutes)
		277VAC, 60Hz (2.6-3.1W)	Ni-Cd battery (Min. 90 Minutes)
Green	AC-Only	120VAC, 60Hz (2.8-3.3W)	-
		277VAC, 60Hz (3.5-4W)	-
	Self-powered	120VAC, 60Hz (2.8-3.3W)	Ni-Cd battery (Min. 90 Minutes)
		277VAC, 60Hz (3.5-4W)	Ni-Cd battery (Min. 90 Minutes)

**Ordering format**

Legend	Series	Legend color
6= 6" EXIT single and double face with universal chevrons and mounting for surface or recessed	UEA= AC only UEN= Self-powered	RM= Red on mirror GM= Green on mirror

**Example: 6UEARM**

## Simplicity™ Universal Combination Edge-Lit Series

Extruded aluminum edge-lit combo

EXIT SIGNS



### Construction

- Extruded aluminum housing and trim plate
- Brushed aluminum finish
- Trim plate includes two fully tool-free adjustable, 2.5W LED heads, 400 Lumens each
- Acrylic panel featuring 6 inch silk-screened EXIT legend with field selectable chevrons
- Single face red or green on clear, double face red or green on mirror

### Mounting

- Wall and ceiling surface and recessed mount
- Universal mounting on wall or ceiling, for surface or recessed applications
- Adjustable bar hanger included for recessed applications

### Electronics

- High temperature long life Nickel Metal Hydride battery provides 90 minutes of emergency operation
- 120/277VAC 60Hz
- Optional: Improved-Diagnostics

### Approvals

- UL 924 listed
- Damp location 41°F to 104°F (5°C to 40°C)

### Warranty (subject to proper installation and maintenance)

Unit has a three-year limited warranty

Detailed warranty terms located online at: [www.lightalarms.com](http://www.lightalarms.com)



### Photometric performance

	Spacing center-to-center (feet)
Series	7.5 feet mounting height
C6UEN*6	30'

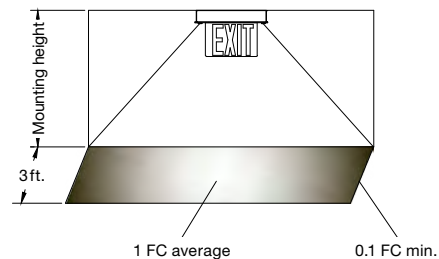



**Dimensions** (dimensions are approximate and subject to change):

**Surface ceiling mount**

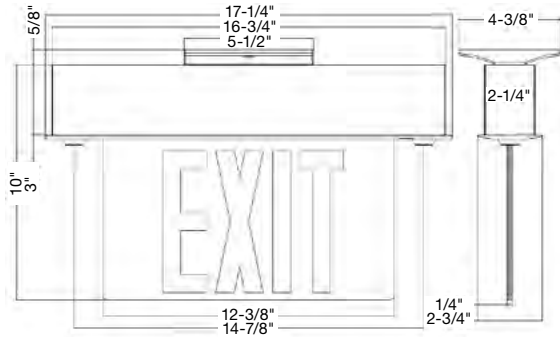

**Surface recessed wall mount**

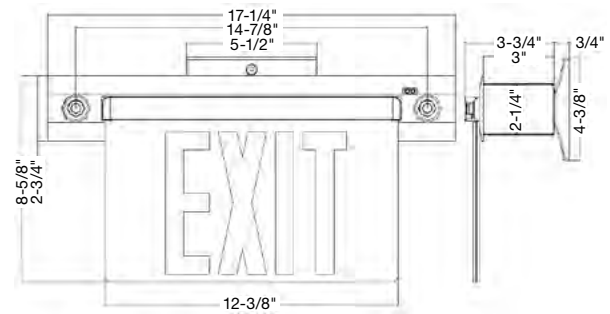

**Recessed ceiling mount**

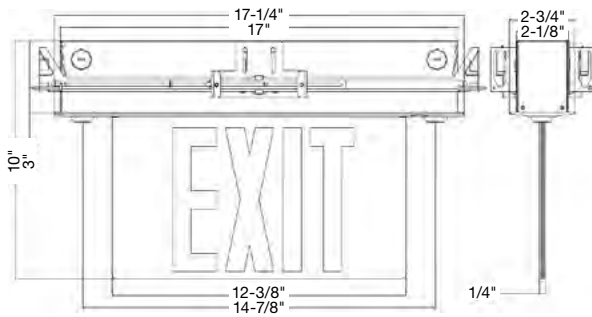

**Recessed wall mount**

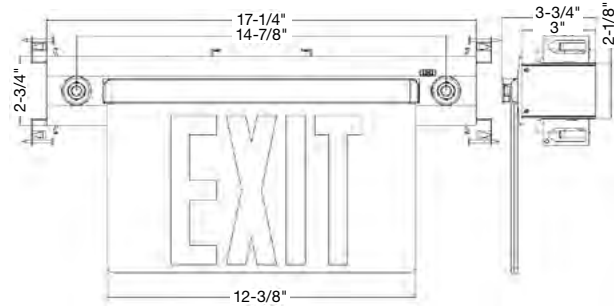

**Power consumption chart**

Series	AC input	Voltage	Battery
C6UENRM-2HO	120/277VAC, 60Hz	3.6V	NiHM 1800mAH
C6UENGM-2HO			NiHM 1800mAH
C6UENRM-2HO-ID			NiHM 2500mAH
C6UENGM-2HO-ID			NiHM 2500mAH

**Ordering format**

Model	Legend	Series	Legend color	Heads	Options
<b>C</b> = Combo	<b>6</b> = 6" EXIT single and double face with universal chevrons and mounting for surface or recessed	<b>UEN</b> = Self-powered	<b>RM</b> = Red <b>GM</b> = Green	<b>2HO</b> = Two high output LED heads	<b>Blank</b> = Standard <b>ID</b> = Improved-Diagnostics

**Example: C6UENRM-2HO-ID**

## Genesis™ ‘Over The Door & Floor Proximity’ Tandem Series

Single and double face, surface and recessed\* mount edge-lit exit sign



### Construction

- DX, DXN ‘Over the door’ exit faceplate, backplate and canopy are made of die-cast aluminum
- DX, DXN offers 6 inch EXIT lettering legend, available in red or green
- LL “Floor Proximity” exit faceplate is made of die-cast aluminum; backbox is made of steel
- LL offers 6 inch EXIT lettering legend, available in red or green
- Choice of finishes: white, black or brushed aluminum
- Universal field selectable chevrons

### Mounting

- GXM, GXEM surface mount only
- Canopy included for ceiling mount applications
- Backplate features universal knockouts for a standard 4 inch junction box, used in wall mount applications
- FPGXLD surface mount or recessed mount
- Single face model only

### Special Wording Panel

Not available

### Electronics

- Standard Improved Diagnostics on GXEM
- Optional Nexus® monitoring system
- 120-277 60Hz

### Approvals

- CSA-US (To UL 924 standards)
- Meets NFPA101 (Life Safety Code), NFPA 70 NEC, OSHA illumination standards

**Warranty** (subject to proper installation and maintenance)

Five-year limited warranty

Detailed warranty terms located on [page 197](#) or online at: [www.lightalarms.com](http://www.lightalarms.com)



### Power consumption chart

Model		AC Specs	DC Specs
Red	AC-Only	120/277VAC, 60Hz (1.5W)	-
	AC-2 Circuit	120/120VAC & 277/277VAC, 60Hz (2.6W)	-
	Self-powered	120/277VAC, 60Hz (3.8W)	Nickel-Cadnium battery (Min. 90 minutes)
Green	AC-Only	120/277VAC, 60Hz (0.9W)	-
	AC-2 Circuit	120/120VAC & 277/277VAC, 60Hz (3.3W)	-
	Self-powered	120/277VAC, 60Hz (5W)	Nickel-Cadnium battery (Min. 90 minutes)

### Accessories (Order as a separate item)

Description	Product code
Wire Guard	WG11-L

### Frame/Face plate color



Brushed aluminum



Black

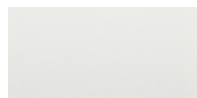

White

**Dimensions** (Dimensions are approximate and subject to change):

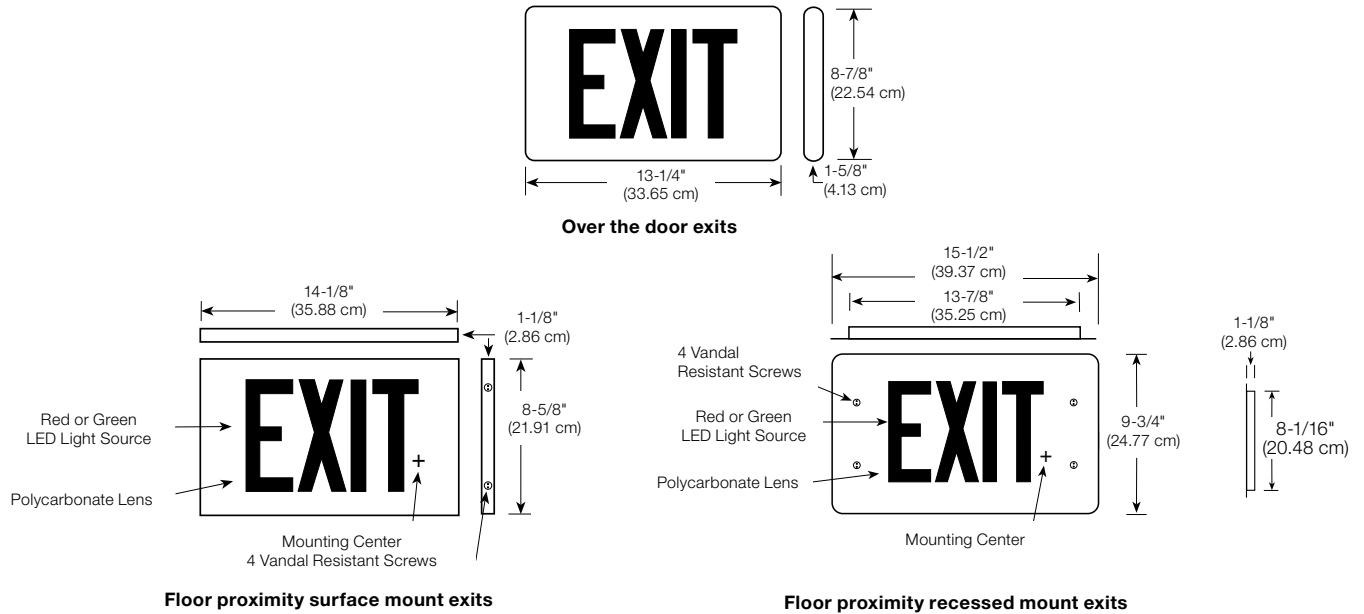

**How to order typical applications** (Must be ordered as a Tandem, over the door with a floor proximity Exit sign):

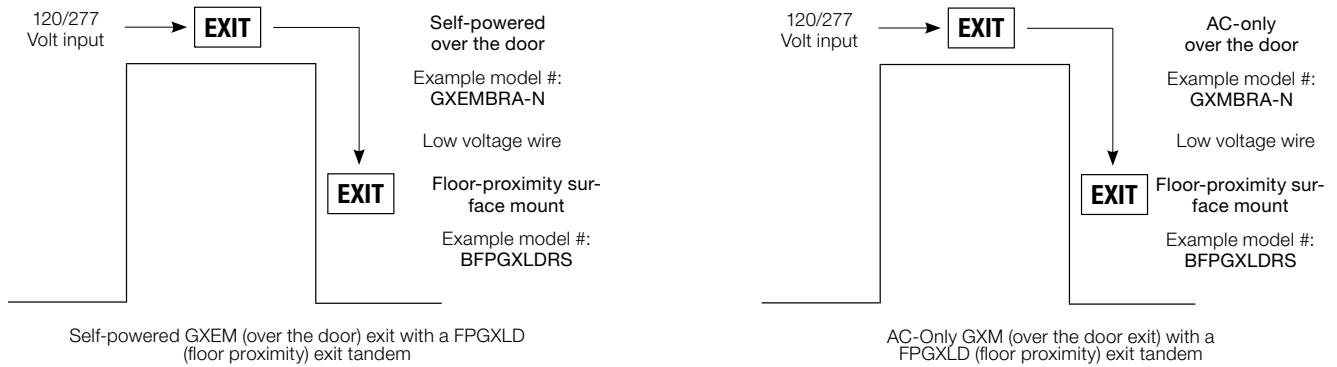

**Ordering format** (Must order 'Over the Door' GX or GXM Exit sign and a "Floor Proximity" FP-GL exit sign as a tandem)

**Over the door exit sign**

Series	Frame color	Legend color	Face plate color	Version	Option
<b>GXM</b> = AC-Only or 2 circuit model <b>GXEM</b> = Self-powered	<b>A</b> = Brushed Aluminum Body <b>B</b> = Black Body <b>W</b> = White Body	<b>R</b> = Red <b>G</b> = Green	<b>A</b> = Brushed Aluminum <b>B</b> = Black <b>W</b> = White	<b>-N</b>	<b>-2</b> = 2 circuit (120/120 or 277/277) (For use with GXM Series)
<b>Example: GXEMBRA-N</b>					

**Floor proximity exit sign**

Frame color	Series	Legend color	Trim	Option
<b>A</b> = Brushed aluminum body <b>B</b> = Black body <b>W</b> = White body	<b>FPGXLD</b> = Floor Proximity Exit	<b>R</b> = Red <b>G</b> = Green	<b>R</b> = Recessed mount <b>S</b> = Surface mount	<b>LVR</b> = Vandal resistant polycarbonate lens and screws
<b>Example: AFGXLDRR</b>				

## Genesis™ GX & GXE Series

Die-cast aluminum LED exit sign



### Construction

- Faceplate, backplate and canopy are made of die-cast aluminum
- 6 inch EXIT lettering legend, available in red or green
- 8 inch EXIT lettering legend, available in red
- Choice of finishes: white, black, brushed aluminum or dark bronze

### Mounting

- Surface mount
- Canopy included for end or ceiling mount applications
- Universal J-Box mounting

### Special Wording Panel

Available. Contact your sales representative with your design requirements

### Electronics

- Standard Improved Diagnostics on GXE
- Optional Nexus® monitoring system
- 120-277 60Hz
- Compatible with Lightalarms Mini Inverters (contact your sales representative for more information)

### Approvals

- CSA-US (To UL 924 standards)
- Damp location optional 50°F to 104°F (10°C to 40°C)
- Meets NFPA101 (Life Safety Code), NFPA 70 NEC, OSHA illumination standards
- E-California Energy Commission Title 20

**Warranty** (subject to proper installation and maintenance)

Five-year limited warranty

Detailed warranty terms located on [page 197](#) or online at: [www.lightalarms.com](http://www.lightalarms.com)



### Power consumption chart

Model (6 inch Exit legend)	AC Specs	DC Specs
AC-only	120 to 347VAC, 50/60Hz (1.25W)	-
AC/DC	120 to 347VAC, 50/60Hz (1.25W)	6 to 48VDC (Less than 1.5W)
Self-powered	120 to 347VAC, 50/60Hz (1.6W)	Ni-Cd battery (Minimum of 90 minutes)
Model (8 inch Exit legend)	AC Specs	DC Specs
AC-only	120 to 347VAC, 50/60Hz (2.5W)	-
AC/DC	120 to 347VAC, 50/60Hz (2.5W)	6 to 48VDC (Less than 1.6W)
Self-powered	120 to 347VAC, 50/60Hz (2.9W)	Ni-Cd battery (Minimum of 90 minutes)

### Frame/Face plate color



Brushed aluminum



Black

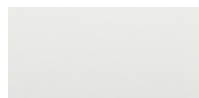

White



Dark bronze (painted)

**Dimensions** (Dimensions are approximate and subject to change):

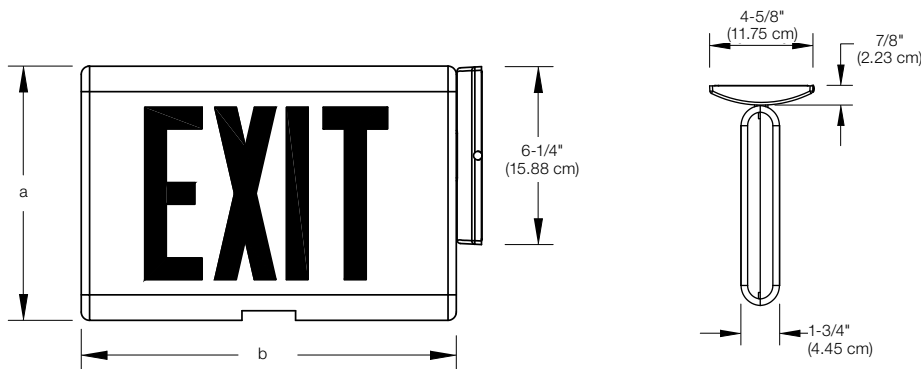

**Accessories** (Order as a separate item)

Description	Product code
Pendant mount white	GPW-*
Pendant mount black	GPB-*
Pendant mount gray	GPA-*
Wire guard (wall mount) (6 in.)	WG13-L
Wire guard (ceiling mount) (6 in.)	WG14-L
Wire guard (end mount) (6 in.)	WG15-L
Vandal shield (wall mount)	VRC
Vandal shield, NEMA-4X (wall mount)	VRC-4X

\* Specify pendant length (12", 24", 36", etc).

**Housing cabinet**

Letters	Dimension A	Dimension B
6" (15.24 cm)	8-7/8" (22.54 cm)	13-1/16" (33.18 cm)
8" (20.32 cm)	10-1/2" (26.67 cm)	15-1/4" (38.74 cm)

**Ordering format**

No. of faces	Series	Back plate/ Frame color	Legend color	Face plate color	Diagnostic option <sup>1</sup>	Options	Version
<b>Blank</b> = 6" single face	<b>GX</b> = AC/DC Only	<b>A</b> = Brushed aluminum	<b>R</b> = Red	<b>A</b> = Brushed aluminum	<b>Blank</b> = Standard	<b>Blank</b> = No option	<b>-N</b> <sup>3</sup>
<b>2</b> = 6" double face	<b>GXE</b> = Self-powered	<b>B</b> = Black	<b>G</b> = Green	<b>B</b> = Black	Improved Diagnostics (non-audible)	<b>-DL</b> = Damp location screws	
<b>8</b> = 8" single face		<b>W</b> = White		<b>W</b> = White	<b>NEX</b> = Nexus® Wired <sup>2</sup> (consult your sales representative)	<b>-VR</b> = Vandal resistant screws	
<b>82</b> = 8" double face		<b>Optional</b> <b>DB</b> = Dark bronze (painted)		<b>Optional</b> <b>DB</b> = Dark bronze (painted)		<b>-LVR</b> = Vandal resistant polycarbonate lens and screws	
						<b>-Y</b> = Open faceplate and Special wording faceplate <sup>4</sup>	
						<b>-2</b> = 2 Circuit (120/120 or 277/277, AC-Only)	

**Example: GXEARA-N**

<sup>1</sup> Available with Self-Powered GXE exit only

<sup>2</sup> NEX is CSA-US approved only

<sup>3</sup> Include when ordering 6" models

<sup>4</sup> Available on 6" models only

## Galaxy™ XD & XDN Series

Die-cast aluminum LED exit sign



### Construction

- Die-cast aluminum housing
- 6 inch EXIT lettering legend available in red or green
- Field-selectable chevrons
- Choice of finishes: white, black or brushed aluminum

### Mounting

- Surface mount
- Canopy included for end or ceiling mount applications
- Universal J-Box mounting

### Electronics

- Optional Improved Diagnostics
- Optional Nexus® monitoring system
- 120/277 60Hz
- Compatible with Lightalarms Mini Inverters (contact your sales representative for more information)

### Special Wording Panels

Available. Contact your sales representative with your design requirements

### Approvals

- UL 924 Listed
- Damp location optional 50°F to 104°F (10°C to 40°C)
- Meets NFPA101 (Life Safety Code), NFPA 70 NEC, OSHA illumination standards
- E-California Energy Commission Title 20

**Warranty** (subject to proper installation and maintenance)

Five-year limited warranty

Detailed warranty terms located on **page 197** or online at: [www.lightalarms.com](http://www.lightalarms.com)



### Frame/Face plate color



Black

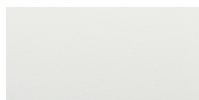

White



Brushed aluminum

**Dimensions** (Dimensions are approximate and subject to change):

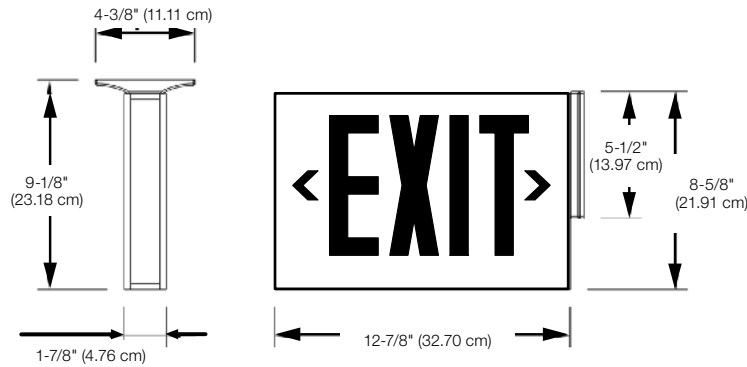

**Power consumption chart**

Model	AC Specs	DC Specs
AC-Only	120/277VAC, 60Hz (Less than 2.5W)	-
AC / DC-remote	120/277VAC, 60Hz (Less than 2W)	6 to 48VDC (Less than 1.5W)
Self-powered	120/277VAC, 60Hz (Less than 3.3W)	Nickel-Cadmium battery (Minimum. of 90 minutes)
Self-powered with diagnostic	120/277VAC, 60Hz (Less than 2.8W)	Nickel-Cadmium battery (Minimum of 90 minutes)

**Accessories** (Order as a separate item)

Product code	Description
Pendant mount white	XD-P*WT
Pendant mount black	XD-P*BK
Pendant mount gray	XD-P*TA
Wire guard (wall mount 6 inch)	WG11-L
Wire guard (ceiling mount 6 inch)	WG14-L
Wire guard (end mount 6 inch)	WH15-L
Vandal shield (wall mount)	VRC
Vandal shield, NEMA-4X (wall mount)	VRC-4X

**Ordering format**

No. of faces	Series	Backplate/ Frame color	Legend/ Face plate color	Option
1= Single face	<b>XDA</b> = AC-Only	<b>B</b> = Black	<b>RB</b> = Red/Black	<b>Blank</b> = No option
2= Double face	<b>XDC</b> = AC/DC	<b>W</b> = White	<b>GB</b> = Green/Black	<b>-DL</b> = Damp location (50°F minimum, 104°F maximum ambient, 10°C minimum, 40°C maximum)
	<b>XD21</b> = Dual AC circuit (2 x 120V)	<b>A</b> = Brushed aluminum	<b>RW</b> = Red/White	<b>-FAF</b> = Fire alarm flasher (not available with XDN model)
	<b>XD22</b> = Dual AC circuit (2 x 277V)		<b>GW</b> = Green/White	<b>-FB</b> = Flasher buzzer <sup>1</sup>
	<b>XDN</b> = Self-powered without Improved Diagnostics		<b>RA</b> = Red/Brushed aluminum	<b>-FBF</b> = Fire alarm activated flasher and Flasher buzzer <sup>1</sup>
	<b>XDND</b> = Self-powered with Improved Diagnostics		<b>GA</b> = Green/Brushed aluminum	<b>-FL</b> = Flasher <sup>1</sup>
	<b>XDNE</b> X= Nexus® Wired (consult your sales representative)			<b>-LVR</b> = Vandal resistant Polycarbonate lens and screws
	<b>XDNE</b> XRF= Nexus® Wireless (consult your sales representative)			<b>-VR</b> = Vandal resistant screws
				<b>-Y</b> = Open faceplate and special wording faceplate

**Example: 2XDABRB**

<sup>1</sup> Available with XDN, XDND, XDNE and XDNE XRF models only.

## Galaxy™ XDPC Series

Die-cast aluminum remote capacity exit sign



### Construction

- Die-cast aluminum housing
- Panel features a curved contour for maximum illumination and clarity
- 6 inch EXIT lettering legend available in red or green
- Field-selectable chevrons
- Choice of finishes: white, black or brushed aluminum

### Mounting

- Surface mount
- Canopy included for end or ceiling mount applications
- Universal J-Box mounting

### Electronics

- Optional Improved Diagnostics
- 120/277 60Hz

### Choice of battery

- XDPCL model, (Lead-calcium battery) 6V-9W remote load capacity
- XDPCN model, (Nickel-Metal Hydride battery) 6V-12W remote load capacity
- XDPCX model, (Nickel-Metal Hydride battery) 6V-24W remote load capacity

### Special Wording Panels

Available. Contact your sales representative with your design requirements

### Approvals

- UL 924 Listed
- Damp location optional 50°F to 104°F (10°C to 40°C)
- Meets NFPA101 (Life Safety Code), NFPA 70 NEC, OSHA illumination standards

**Warranty** (subject to proper installation and maintenance)

Five-year limited warranty

Detailed warranty terms located on **page 197** or online at: [www.lightalarms.com](http://www.lightalarms.com)



### Face plate color



Brushed aluminum



Black

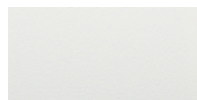

White



**Dimensions** (Dimensions are approximate and subject to change):

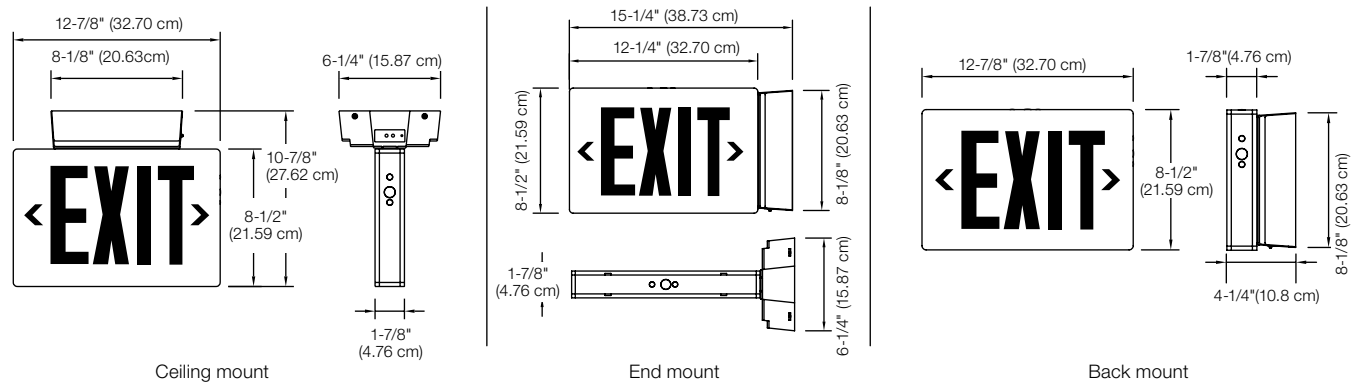

**Power consumption chart**

Series	AC Specs				DC Specs			
	AC Input	Maximum	Voltage	Battery	Battery capacity in watts			
					1-1/2 hrs.	2 hrs.	3 hrs.	4 hrs.
XDPCCL	120/277VAC, 60Hz	0.13/0.06A (15W)	6V	Lead-calcium	9	-	-	-
XDPCN	120/277VAC, 60Hz	0.13/0.06A (15W)	6V	Nickel-Metal Hydride	12	9	-	-
XDPCX	120/277VAC, 60Hz	0.13/0.06A (15W)	6V	Nickel-Metal Hydride	24	18	12	9

**Accessories** (Order as a separate item)

Product code	Description
WG13-L	Wire guard, back mount
WG14-L	Wire guard, ceiling mount

**Ordering format**

No. of faces	Series	Battery	Back plate/ Frame color	Legend/ Face plate color	Options
1= Single face 2= Double face	<b>XDPC</b> = LED exit	<b>Lead-calcium</b> L= 6V-9W remote capacity  <b>Nickel Metal Hydride</b> N= 6V-12W remote capacity X= 6V-24W remote capacity	<b>B</b> = Black <b>W</b> = White <b>A</b> = Brushed aluminum	<b>RB</b> = Red/Black <b>GB</b> = Green/Black <b>RW</b> = Red/White <b>GW</b> = Green/White <b>RA</b> = Red/Brushed aluminum <b>GA</b> = Green/Brushed aluminum	<b>Blank</b> = No options <b>-ID</b> = Improved Diagnostics (audible) <b>-IDNA</b> = Improved Diagnostics (non-audible)

**Example: 2XDPCCLBRAIDNA**

<sup>1</sup> Not available with ID and IDNA options  
<sup>2</sup> Comes standard with ID and IDNA options

## Galaxy™ Slim TX & TXE Series

Die-cast aluminum slim profile exit sign



### Construction

- Die-cast aluminum
- 6 inch EXIT lettering legend, available in red or green
- Choice of finishes: all white, or black with brushed aluminum faceplate
- Field-selectable chevrons

### Mounting

- Surface mount
- Canopy included for end or ceiling mount applications
- Universal J-box mounting

### Electronics

Compatible with Lightalarms Mini Inverters (contact your sales representative for more information)

**Dimensions** (Dimensions are approximate and subject to change):

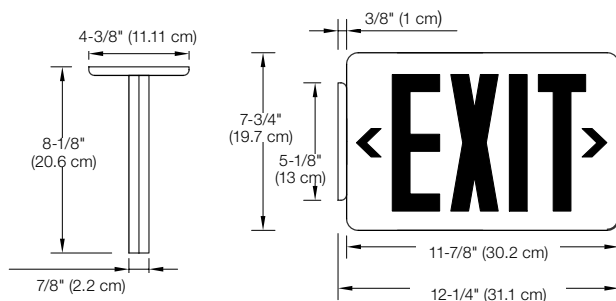

### Approvals

- UL 924 listed
- Damp location optional  
50°F to 104°F (10°C to 40°C)
- Meets NFPA101 (Life Safety Code), NFPA 70 NEC, OSHA illumination standards

### Warranty

Three-year full warranty

Detailed warranty terms located on [page 197](#) or online at: [www.lightalarms.com](http://www.lightalarms.com)



### Power consumption chart

Model	AC Specs	DC Specs
AC-only	120/277VAC, 60Hz, Typical 1W (Less than 1.5W)	-
Self-powered	120/277VAC, 60Hz, Less than 3.3W (Less than 1.5)	Nd-Cd battery (Min. 90 mins)

### Accessories (Order as a separate item)

Product code	Description
WG1-L	Wire Guard (Wall Mount)
WG5-L	Wire Guard (Ceiling Mount & End Mount)

### Face plate color



Brushed aluminum

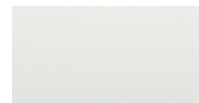

White

### Ordering format

No. of faces	Series	Backplate color	Legend color	Face plate color
Blank= Single face	TX= AC-Only	W= White	R= Red	W= White (only available with white backplate)
2= Double face	TXE= Self-powered	B= Black	G= Green	A= Brushed aluminum (only available with black backplate)

**Example: TXEWRW**

## Galaxy™ XLD & XLED Series

LED die-cast aluminum exit fully recessed mount AC, AC/DC or self-powered exit signs



### Construction

- Die-cast aluminum faceplate
- 6 inch EXIT lettering legend available in red or green
- Field-selectable chevrons
- Choice of finishes: white, black or brushed aluminum

### Mounting

Fully recessed mount

### Electronics

- Standard Improved Diagnostics (self -powered models)
- 120/277 60Hz

### Special Wording Panels

Available. Contact your sales representative with your design requirements

**Dimensions** (Dimensions are approximate and subject to change):

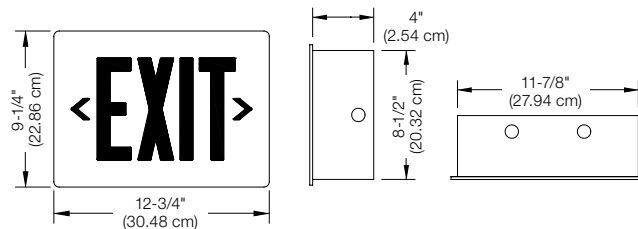

### Approvals

- UL 924 Listed
- CSA US ( to UL924 Standards)
- Meets NFPA101 (Life Safety Code), NFPA 70 NEC, OSHA illumination standards
- E-California Energy Commission Title 20

### Warranty

Five-year limited warranty

Detailed warranty terms located on [page 197](#) or online at: [www.lightalarms.com](http://www.lightalarms.com)



### Power consumption chart

Model	AC Specs	DC Specs
AC	120VAC, 60Hz (Less than 1.4W)	—
AC/DC	277VAC, 60Hz (Less than 2W)	6VDC-48VDC (Less than 1.5W)
Self-Powered	120VAC, 60Hz (Less then 1.7W)	Ni-Cd battery (Min. 90 Minutes)

### Face plate color

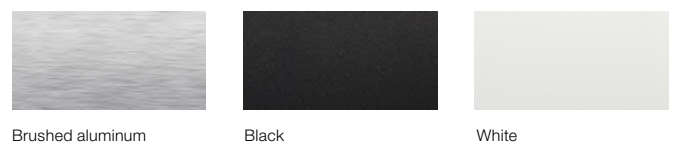

### Ordering format

Model	Series	Legend/stencil color	Housing color	Options
<b>R=</b> Fully recessed mounting (single face only)	<b>-XLD=</b> AC, AC/DC <b>-XLED=</b> Self-Powered standard with self-diagnostic Ni-Cd battery	<b>R=</b> Red <b>G=</b> Green	<b>A=</b> Aluminum face <b>W=</b> White face <b>B=</b> Black face	<b>-DL=</b> Damp location <b>-FB=</b> Flasher buzzer (Self-Powered) <b>-FAF=</b> Fire alarm activated flasher (AC) <b>-FAF=</b> Fire alarm activated flasher (Self-Powered) <b>-VR=</b> Vandal resist screws <b>-LVR=</b> Vandal resist shield and screws <b>-2=</b> Dual circuit operation (AC only) <b>-Y=</b> Open face
<b>Example: R-XLEDRW-N</b>				<b>-N=</b> New design

## UX4 LED Steel Exit and Combination Series

Steel LED exit signs and combination units



### Construction

- Steel housing
- Standard mist-white finish, optional black finish
- Heads available in thermoplastic
- 6 inch EXIT lettering legend, available in red or green
- Field-selectable chevrons

### Mounting

- Surface mount
- Canopy included for end or ceiling mount applications
- Universal J-Box mounting

### Combo units

- UX4E Model, Lead-calcium battery, 6V-30W total battery capacity
- UX4EN Model, Nickel-Cadmium battery, 6V-24W total battery capacity

### Exit sign

- UX4 Model, Exit Sign, AC-Only, 120/277VAC, 50/60Hz
- UX4N Model, Nickel-Cadmium battery

### Photometric performance

Lamp	Spacing center-to-center (feet)	
	7 feet mounting height	15 feet mounting height
LD1	43'	36'
LD2	81'	64'

### Unit Rating Chart (Combination unit)

Battery type	DC Voltage (Volts)	Model	Battery capacity in watts			
			1-1/2 hrs.	2 hrs.	3 hrs.	4 hrs.
Lead-calcium	6	UX4E	30	20	14	10
Nickel-Cadmium	6	UX4EN	24	18	12	9

### Lamp Head Source

- MR16 LED 6V 4W or 6V 5W

### Electronics

- Improved Diagnostics
- Optional Nexus® monitoring system
- 120/277 60Hz

### Special Wording Panels

Available. Contact your sales representative with your design requirements

### Approvals

- UL 924 listed
- Meets NFPA101 (Life Safety Code), NFPA 70-NEC and OSHA illumination standards
- E-California Energy Commission Title 20 (Exit sign only)

### Warranty (subject to proper installation and maintenance)

Three-year limited warranty

Detailed warranty terms located on [page 197](#) or online at: [www.lightalarms.com](http://www.lightalarms.com)

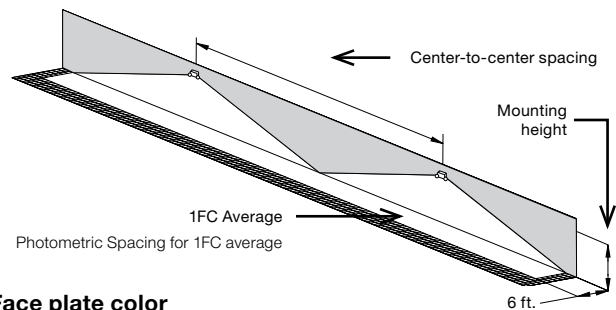

### Face plate color



Brushed aluminum



Black

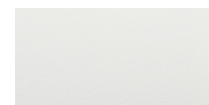

White

**Dimensions** (Dimensions are approximate and subject to change):

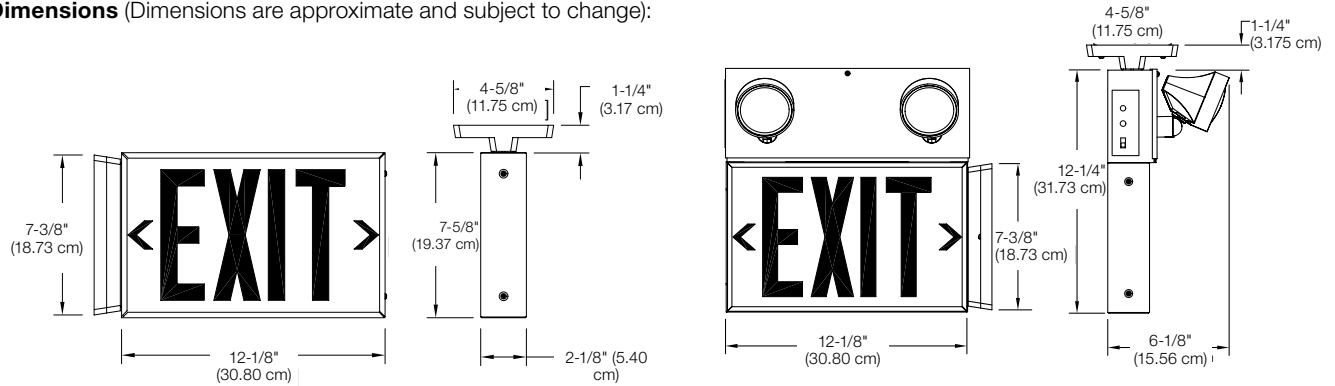

**Power consumption chart**

Model	AC Specs	DC Specs
AC-Only	120-277VAC, 50/60Hz (Less than 1.5W)	-
AC/DC	120-277VAC, 50/60Hz (Less than 1.5W)	6 to 24VDC (Less than 1.5W)
Self-powered	120-277VAC, 50/60Hz (Less than 3W)	Nd-Cd battery (Min. 90 minutes)
Combination	120-277VAC, 50/60Hz (Less than 5W)	See unit rating chart

**Accessories** (Order as a separate item)

Description	Product code
White pendant	PW-*
Black pendant	PB-*
Wire guard (exit-ceiling or end mount)	WG5-L
Wire guard (exit-wall mount)	WG12-L
Wire guard (combination unit-wall mount)	WG6-L

\*Specify pendant length (12", 24", 36" etc.)

**Ordering format – AC-only and Self-powered Models**

Series	Battery type	Back plate/ Frame color	Legend/ Face Plate Color	Legend source	Options
<b>UX4</b> = Universal (2) faceplates, (1) backplate and (1) canopy	<b>Blank</b> = AC-only <b>N</b> = Self-powered	<b>W</b> = White <b>B</b> = Black	<b>RW</b> = Red/White <b>RB</b> = Red/Black <b>RA</b> = Red/Aluminum <b>GW</b> = Green/White <b>GB</b> = Green/Black <b>GA</b> = Green/Aluminum	<b>LED</b> = LED	<b>Blank</b> = No options <b>-ID</b> = Improved Diagnostics <b>-NEX</b> = Nexus® wired <sup>1</sup> (consult your sales representative) <b>-NEXRF</b> = Nexus® wireless <sup>1</sup> (consult your sales representative) <b>-DC</b> = AC/DC 6V-24VDC <b>-VR</b> = Vandal resistant screws & lens

**Example: UX4WRWLED**

<sup>1</sup> Available in self-powered only

**Ordering format – UX4 LED Steel Exit & Combination units**

Series	Unit type	Back plate/ Frame color	Legend/ Face plate color	Legend source	Lamp head suffix	Lamp options	Options
<b>UX4</b> = Universal (2) faceplates, (1) backplate and (1) canopy	<b>E</b> = 6V-30W lead-calcium battery <b>EN</b> = 6V-24W Nickel-Cadmium battery	<b>W</b> = White <b>B</b> = Black	<b>RW</b> = Red/White <b>RB</b> = Red/Black <b>RA</b> = Red/Aluminum <b>GW</b> = Green/White <b>GB</b> = Green/Black <b>GA</b> = Green/Aluminum	<b>LED</b> = LED	<b>/0</b> = No heads <b>/1ELF3</b> = (1) ELF3 head <b>/2ELF3</b> = (2) ELF3 heads	<b>LD1</b> = 6V-4W MR16 LED <b>LD2</b> = 6V-5W MR16 LED	<b>Blank</b> = No options <b>-ID</b> = Improved Diagnostics (audible) <sup>1</sup> <b>-IDNA</b> = Improved Diagnostics (non-audible) <sup>1</sup> <b>-NEX</b> = Nexus® wired <sup>1</sup> - combo unit only (consult your sales representative) <b>-NEXRF</b> = Nexus® wireless <sup>1</sup> - combo unit only (consult your sales representative) <b>-T3</b> = Time Delay 15 minutes <b>-VR</b> = Vandal resistant screws

**Example: UX4EWRWLED/2ELFLD1**

<sup>1</sup> Not available with EN model

## Grande™ Exit Series

Specification-grade, LED, thermoplastic, snap together exit sign



### Grande™ Thermoplastic Family



Grande™  
Combo series  
PG. 38-39



Grande™ Compact  
Battery series  
PG. 88-89



Grande™  
Battery series  
PG. 90-91



ELF640 &  
ELF650  
Remote series  
PG. 136-137

#### Construction

- Mist white or black UV stabilized thermoplastic enclosure
- 6 inch EXIT lettering legend, available in red or green
- Field-selectable chevrons

#### Mounting

- Surface mount
- Canopy included for end or ceiling mount applications
- Universal J-Box mounting

#### Special Wording Panels

Available. Contact your sales representative with your design requirements

#### Electronics

- Optional Improved Diagnostics
- Optional Nexus®Pro IoT monitoring system
- Optional Nexus® wired and wireless monitoring system
- 120/277 60Hz
- Compatible with Lightalarms Mini Inverters (contact your sales representative for more information)

#### Approvals

- UL 924 Listed
- Damp location 32°F to 104°F (0°C to 40°C)
- Meets NFPA101 (Life Safety Code), NFPA 70 NEC, OSHA illumination standards
- E-California Energy Commission Title 20

#### Warranty (subject to proper installation and maintenance)

Five-year limited warranty

Detailed warranty terms located on [page 197](#) or online at: [www.lightalarms.com](http://www.lightalarms.com)



#### Housing color



Black

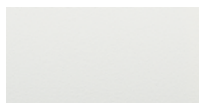

White

**Dimensions** (Dimensions are approximate and subject to change):

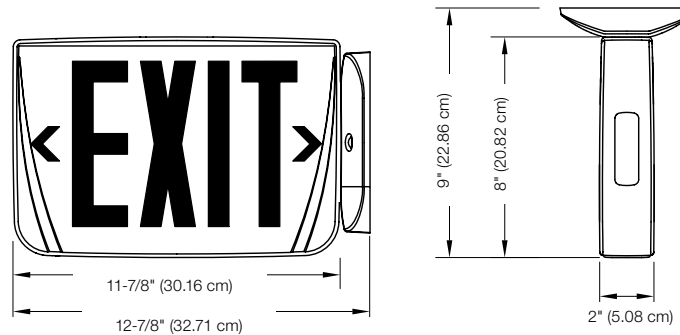

**Power consumption chart**

Model	AC Specs	DC Specs
AC-Only	120/277VAC, 60Hz (Less than 2.5W)	-
AC / DC-remote	120/277VAC, 60Hz (Less than 2W)	6 to 48VDC (Less than 1.5W)
Self-powered	120/277VAC, 60Hz (Less than 3.3W)	Nickel-Cadmium battery (Min . 90 minutes)
Self-powered with Diagnostic	120/277VAC, 60Hz (Less than 2.8W)	Nickel-Cadmium battery (Min . 90 minutes)

**Accessories** (Order as a separate item)

Description	Product Code
Wire guard, Back mount	WG1-L
Wire guard (ceiling mount and end mount)	WG5-L
Pendant white	GRA-P*-W
Pendant black	GRA-P*-B

\*Specify pendant length (12", 24", 36" etc)

**Ordering format**

Series	Unit type	Legend color/ # of face	Housing color	Options
<b>GRAN</b>	<b>AC</b> = AC-Only (120/277V) <b>DC</b> = 120/277VAC & 6 to 48VDC <b>21</b> = Dual AC circuit (2x120V) <b>22</b> = Dual AC circuit (2x277V) <b>N</b> = Self-powered Nickel-Cadmium <b>ND</b> = Self-powered with Improved Diagnostics circuitry - <b>NEX</b> = Nexus® wired <sup>1</sup> - <b>NEXP</b> = Nexus®Pro IoT <sup>1</sup> - <b>NEXRF</b> = Nexus® wireless <sup>1</sup>	<b>R</b> = Red universal <b>G</b> = Green universal <b>R1</b> = Red single face <sup>3</sup> <b>R2</b> = Red double face <sup>3</sup> <b>G1</b> = Green single face <sup>3</sup> <b>G2</b> = Green double face <sup>3</sup> <b>Open face</b> <sup>2</sup> <b>RW</b> = Red on white universal <b>GW</b> = Green on white universal  <b>Universal</b> = (2) faceplates, (1) backplate and (1) canopy <b>Single face</b> = (1) faceplate, (1) backplate and (1) canopy <b>Double face</b> = (2) faceplates and (1) canopy	<b>W</b> = White <b>B</b> = Black	<b>BA</b> = Brushed aluminum exit stencil - <b>FAF</b> = Fire alarm activated flasher (AC, DC, 21,22 or ND models only) - <b>FB</b> = Flasher buzzer (ND model only) - <b>FBF</b> = Flasher Buzzer + Fire alarm activated flasher (ND model only) - <b>FL</b> = Flasher (ND model only) - <b>LVR1</b> = Polycarbonate shield with tamper proof screws - <b>VR</b> = Vandal-resistant screws

**Example: GRANACRW**

<sup>1</sup> Consult your sales representative

<sup>2</sup> Open face required with special wording legends

<sup>3</sup> Specify single or double for LVR1 or VR options only

## Grande™ Combination Series

Specification-grade, LED, thermoplastic, snap-together combination unit



### Grande™ Thermoplastic Family



Grande™ Exit series PG. 36-37    Grande™ Compact Battery series PG. 88-89    Grande™ Battery series PG. 90-91    ELF640 & ELF650 Remote series PG. 136-137

#### Construction

- Mist white or black UV stabilized thermoplastic enclosure
- Clear polycarbonate lens covers
- Choice of MR16 LED lamp voltages and wattages
- 6 inch EXIT lettering legend, available in red or green
- Field-selectable chevrons

#### Mounting

- Surface mount
- Canopy included for ceiling mount applications
- Universal J-Box mounting

#### Choice of battery

- 6V or 12V lead-calcium battery
- 6V or 12V Nickel-metal hydride battery

#### Special Wording Panels

Available, contact your sales representative with your design requirements

#### Electronics

- Optional Improved Diagnostics
- Optional Nexus®Pro IoT monitoring system
- Optional Nexus® wired and wireless monitoring system
- 120/277 60Hz

#### Approvals

- UL 924 Standards listed
- Nickel-Metal Hydride battery combination units UL listed for damp location 50°F to 104°F (10°C to 40°C)
- Meets NFPA101 (Life Safety Code), NFPA 70 NEC, OSHA illumination standards

**Warranty** (subject to proper installation and maintenance)

Five-year full warranty

Detailed warranty terms located on **page 197** or online at: [www.lightalarms.com](http://www.lightalarms.com)



#### Photometric performance

Lamp	Spacing center-to-center (feet)	
	7 feet mounting height	15 feet mounting height
LD1	39'	34'
LD2	74'	57'
LD7	49'	39'
LD9	68'	54'
LD10	89'	60'

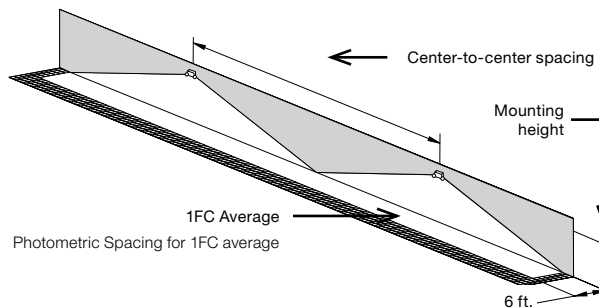

#### Housing color



Black

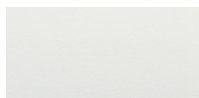

White



**Dimensions** (Dimensions are approximate and subject to change):

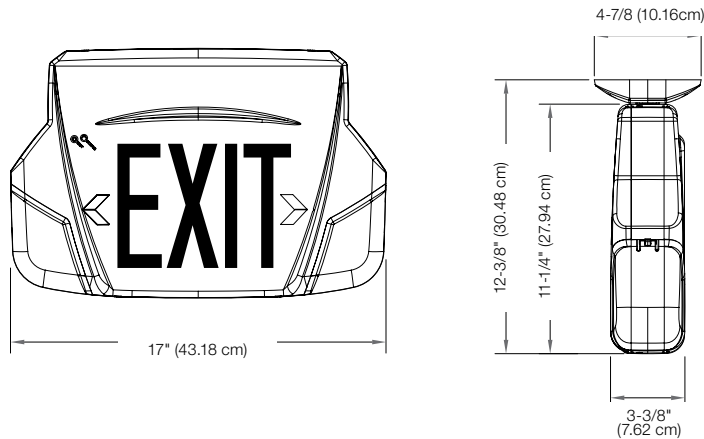

**Accessories** (Order as a separate item)

Description	Product code
Wire guard (wall mount)	WG2-L
Pendant white	GRA-P <sup>1</sup> -W
Pendant black	GRA-P <sup>1</sup> -B

<sup>1</sup>Specify pendant length (12", 24", 36" etc.)

**Convert to single face to double face in the field**

Description	Product code
Red/white	005715-L
Red/black	005716-L
Green/white	005717-L
Green/black	005718-L

**Power consumption chart**

Series	AC input	AC Specs		DC Specs				
		Current draw	Voltage	Battery	Battery capacity in watts <sup>1</sup>			
					1-1/2hrs	2 hrs	3 hrs	4 hrs
GR612M			6V	Lead-calcium	12	8	—	—
GR612H		0.11/0.05A	6V	Nickel-Metal Hydride	12	9	—	—
GR624M			6V	Lead-calcium	24	16	12	9
GR1224M	120/277VAC, 60Hz		12V	Lead-calcium	24	16	12	9
GR1224H			12V	Nickel-Metal Hydride	24	18	12	9
GR1240H		0.22/0.08A	12V	Nickel-Metal Hydride	40	30	20	15
GR1250H			12V	Nickel-Metal Hydride	50	36	24	18

<sup>1</sup>National Electrical Code specification. Note: LED Exit AC Illumination draws less than 2W.

**Ordering format**

Series/ battery type/ capacity	Legend color	# of face	Housing color	# of heads	Lamp type	Options
<b>Lead-calcium</b> GR612M= 6V-12W GR624M= 6V-24W GR1224M= 12V-24W	<b>R</b> = Red <b>G</b> = Green	<b>1</b> = Single face (ceiling or wall mount) <b>1N</b> = Single face no canopy (wall mount)	<b>W</b> = White <b>B</b> = Black	<b>Blank</b> = No heads <b>2</b> = Two heads	<b>MR16 LED Lamps</b> LD1= 6V-4W LD2= 6V-5W LD7= 12V-4W LD9=12V-5W LD10=12V-6W	<b>Blank</b> = No option <b>-ID</b> = Improved Diagnostics (audible) <sup>1</sup> <b>-IDNA</b> = Improved Diagnostics (non-audible) <sup>1</sup> <b>-NEX</b> = Nexus <sup>®</sup> wired <sup>1</sup> <b>-NEXP</b> = Nexus <sup>®</sup> Pro IoT <sup>1</sup> <b>-NEXRF</b> = Nexus <sup>®</sup> wireless <sup>1</sup> <b>-BA</b> = Brushed aluminum exit stencil <b>-FAF</b> = Fire alarm activated flasher <b>-FB</b> = Flasher buzzer <b>-FBF</b> = Flasher buzzer + Fire alarm activated flasher <b>-FL</b> = Flasher <b>-LVR1</b> = Vandal resistant Polycarbonate lens and screws <sup>2</sup> <b>-T3</b> = Time delay (15 minutes) <b>-VR</b> = Vandal resistant screws <sup>2</sup>
<b>Nickel Metal Hydride rated damp location</b> GR612H= 6V-12W GR1224H= 12V-24W GR1240H= 12V-40W GR1250H= 12V-50W		<b>2</b> = Double face (ceiling mount) <b>U</b> = Universal 2 faces, backplate and canopy				

**Example: GR612MR1W2LD10**

<sup>1</sup>Not available with GR1250H  
<sup>2</sup>Not available with universal faces

## Quick™ QLX & QLXN Series

Economical, thermoplastic LED exit signs



### Construction

- UV stabilized thermoplastic body
- 6 inch EXIT lettering legend, available in red or green
- Field selectable chevrons

### Mounting

- Surface mount
- Canopy included for end or ceiling mount applications
- Universal J-Box mounting

### Electronics

- Optional Improved Diagnostics
- 120/277 60Hz
- Sealed maintenance free Nickel-Cadmium battery for self-powered models
- Compatible with Lightalarms Mini Inverters (contact your sales representative for more information)

### Power consumption chart

AC input
120/277VAC, 60Hz maximum 2.5W

### Accessories (Order as a separate item)

Description	Product code
Wire guard (wall mount)	WG1-L
Wire guard (ceiling mount and end mount)	WG5-L

### Ordering format

Series	Legend color	Options
QLX500= AC-Only	RN= Red	Blank= No option
QLXN500= Self-powered	GN= Green	-ID= Improved Diagnostics (audible) <sup>1</sup>
<b>Example: QLXN500RN</b>		-RID= Remote capacity 3.6V-3.6W Improved Diagnostics (audible) <sup>1,2</sup>

<sup>1</sup> Available with red legend only

<sup>2</sup> Remote capacity for (1) LCARDSQLED, (1) ELF612D/LED or (2) ELF612/LED remote heads only

### Finishes

Mist white

### Approvals

- UL 924 listed
- Damp location 50°F to 104°F (10°C to 40°C)
- UL 94, 5VA flame rated

### Warranty (subject to proper installation and maintenance)

Three-year full warranty

Detailed warranty terms located on **page 197** or online at: [www.lightalarms.com](http://www.lightalarms.com)



### Dimensions

(Dimensions are approximate and subject to change):

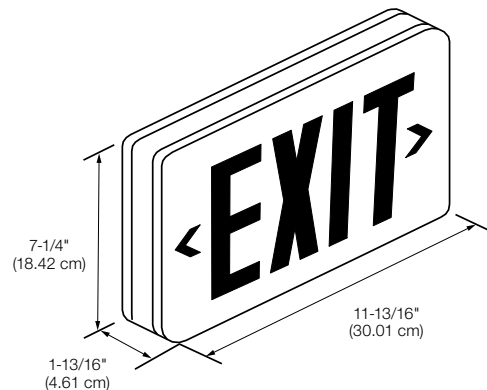

## Quick™ QLX & QLXN Series

Economical, thermoplastic LED black exit signs



### Construction

- UV stabilized thermoplastic body
- 6 inch EXIT lettering legend, available in red or green
- Field selectable chevrons

### Mounting

- Surface mount
- Canopy included for end or ceiling mount applications
- Universal J-Box mounting

### Finishes

Black

### Electronics

- 120/277 60Hz
- Sealed maintenance free Nickel-Cadmium battery for self-powered models

### Approvals

- UL 924 listed
- Damp location 50°F to 104°F (10°C to 40°C)
- UL 94, 5VA flame rated

### Warranty (subject to proper installation and maintenance)

Three-year full warranty

Detailed warranty terms located on [page 197](#) or online at: [www.lightalarms.com](http://www.lightalarms.com)



### Power consumption chart

AC input
120/277VAC, 60Hz maximum 2.5W

### Accessories (Order as a separate item)

Description	Product code
Wire guard (wall mount)	WG1-L
Wire guard (ceiling mount and end mount)	WG5-L

### Ordering format

Series	Legend color	Options
QLX500= AC-Only QLXN500= Self-powered	RB= Red GB= Green <sup>1</sup>	Blank= No option

**Example: QLXN500RB**

### Dimensions

Dimensions are approximate and subject to change:

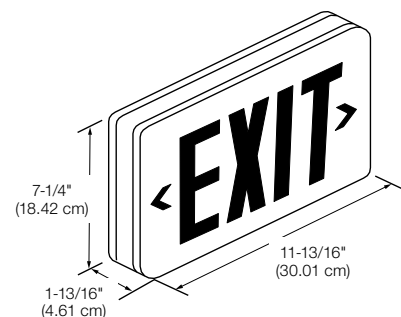

<sup>1</sup> Available on AC Exit only

## LAXC LED Series

Combination unit with light bar



### Construction

- Off-white UV stabilized thermoplastic enclosure
- 6 inch EXIT lettering legend, available in red or green
- Universal single or double face
- Field selectable chevrons
- Light bar consumes 4.5 watts
- Adjustable lens for optimal light output
- 5VA Flame retardant thermoplastic
- Remote capacity for (1) ELF612D/LED or (2) ELF612/LED

### Mounting

- Surface and wall mount
- Canopy included for end or ceiling mount application
- Universal J-box mounting

### Photometric performance

Spacing center-to-center (feet)
7.5 feet mounting height
12'

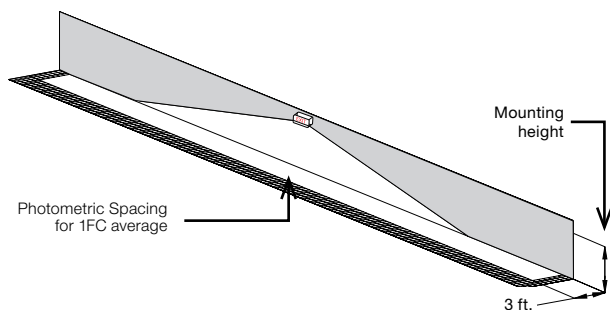

### Ordering format

Series	Legend color
LAXC= Combination unit with light bar	-RLP= RED with light bar -GLP= GREEN with light bar

Example: LAXC-RLP

### Electronics

- 120/27760 Hz
- 4.8V long life nickel cadmium battery

### Approvals

- UL 924 listed
- Damp location 32°F to 122°F (0°C to 50°C)

### Warranty

Three-year full warranty

Detailed warranty terms located on page 197 of the catalog or online at: [www.lightalarms.com](http://www.lightalarms.com)



### Accessories (Order as a separate item)

Product code	Description
Wire guard (wall mount)	WG1-L
Wire guard (ceiling or end mount)	WG5-L
Pendant white	PW*

\*Specify length of pendant (12", 24", 36" etc.)

### Power consumption chart

Model	AC Specs	DC Specs
LAXC-RLP	120/277VAC, 7.5W	4.8V nickel-cadmium battery (min. 90 minutes)
LAXC-GLP	120/277VAC, 7.5W	4.8V nickel-cadmium battery (min. 90 minutes)

**Dimensions** (Dimensions are approximate and subject to change):

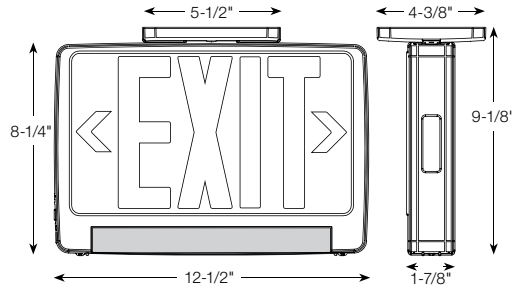

### ELF612D/LED Series

Thermoplastic square LED outdoor remote heads



**Housing**

- ELF612D/LED remote series is multi-volt 3.6, 6 or 12V, 3W total
- Thermoplastic housing and aluminum canopy with fully adjustable LED heads
- Suitable for outdoor application
- Suitable for wet location applications
- Wall or ceiling mount
- Available only in gray or black, single or double head configuration

**Dimensions** (Dimensions are approximate and subject to change):

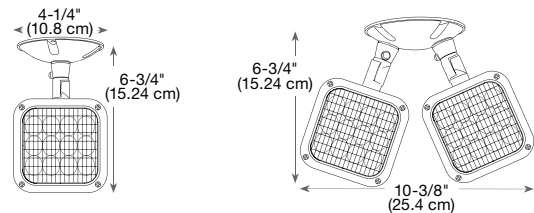

**Approvals**

- UL924 Listed

**Warranty** (subject to proper installation and maintenance)

Three-year full warranty

**Ordering format – ELF612D/LED Series**

Series	Options	Color
ELF612= Single	/LED= Thermoplastic square LED head	<b>Blank</b> = Gray
ELF612D= Double		<b>BK</b> = Black

**Example: ELF612D/LED**

## Square Head LED LCAC-2SQLED Series

LED Exit and heads thermoplastic combination unit



### Construction

- Frame, faceplate, backplate and canopy are made of thermoplastic
- 6 inch exit lettering legend, available in red or green

### Mounting

- Surface mount
- Universal model includes (2) faceplates, (1) backplate and (1) canopy
- Canopy included for ceiling mount applications / end mount
- Backplate features universal knockouts for a standard 4 inch junction box used in wall mount applications

### Finishes

Finished in mist-white

### Chevrons

Faceplate includes two field-selectable, snap-in/out chevron indicators

### Exit legend LEDs

Red or green long-life Light Emitting Diodes (LED) illumination

### Remote Capacity/combination units

LCAC-2SQLEDR and LCAC-2SQLEDRID feature a 3.6V Ni-Cd battery with two 1W LED heads attached as well as 3W of remote capacity for ELF612D/LED or LCARDSQLED

### Power consumption chart

AC input
120/277VAC, 60Hz, 0.048A

### Accessories (Order as a separate item)

Description	Product code
Wire Guard (heads in any position) wall mount	WG10-L
Replacement battery LCAC	022434-L
Replacement battery LCAC-2SQLEDR & LCAC-2SQLEDRID	022435-L

### Square Heads LED Family



Quick™ QLX & QLXN  
Exit series  
PG. 40-41

LCAB  
Battery unit  
PG. 84-85

LCARD  
Remote head  
PG. 134

ELF612D  
Remote head  
PG. 135

### Lamp head source

- 3.6V-1W LED head
- Lamp heads are fully adjustable to top or side with no tools required
- Total 200 lumens, LED CCT 6000K

### Self-Diagnostics

Combination models available with or without Improved Diagnostics

### Approvals

- Listed to UL 924 Standards
- UL listed for Damp location 50°F to 104°F (10°C to 40°C)
- Meets NFPA101 (Life Safety Code), NFPA 70 NEC

### Warranty (subject to proper installation and maintenance)

Three-year full warranty

Detailed warranty terms located on [page 197](#) or online at: [www.lightalarms.com](http://www.lightalarms.com)



### Photometric performance

Spacing center-to-center (feet)	
7 feet mounting height	15 feet mounting height
13'	4'

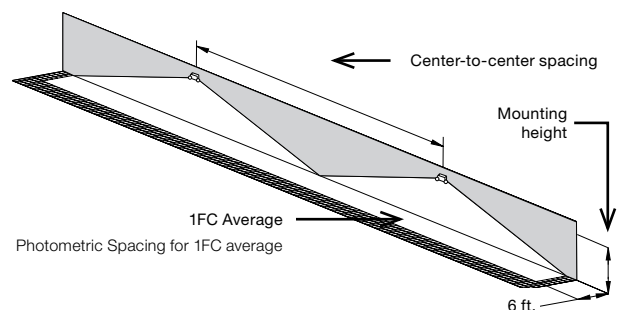

**Dimensions** (Dimensions are approximate and subject to change):

**LCAC-SQLED Combination Series Combination Unit Includes (2) heads only, dimension shown for top mount or side mount applications**

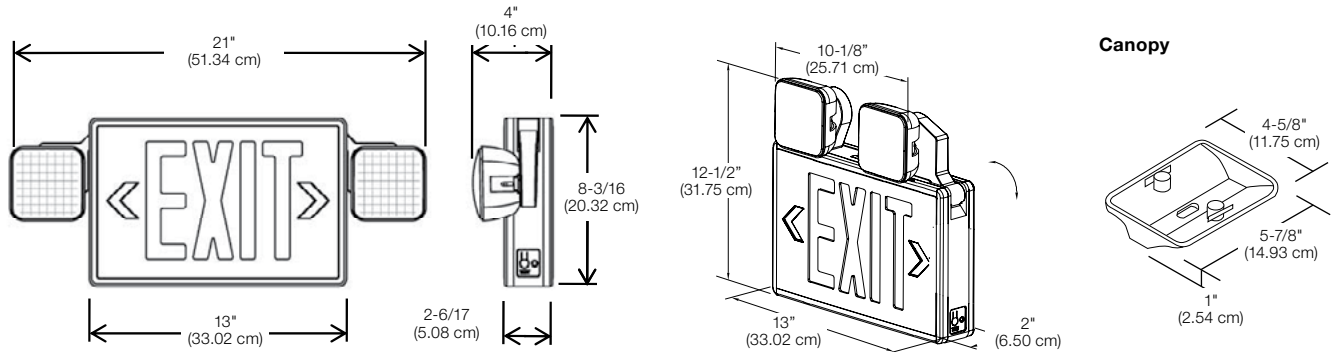

**Ordering format**

Series	Legend color	Head style/ lamp	Options
LCAC	R= Red G= Green	2SQLED= 2 Square 1W each LED heads	Blank= No option R= Remote capacity <sup>1</sup> RID= Remote capacity and Improved Diagnostics <sup>1</sup>
<b>Example: LCACR2SQLEDRID</b>			

<sup>1</sup>To be used with the LCARDSQLED or ELF612/LED remote only.

### LCARDSQLED Series

Thermoplastic square LED indoor remote heads



**Housing**

- Thermoplastic dual head remote
- Wall or ceiling mount

**Lamp information**

- LED 3.6V, 2W total
- 6000K LED color temperature

**Approvals**

- Damp location listed
- UL924 Listed

**Warranty** (subject to proper installation and maintenance)

Three-year full warranty

**Dimensions**

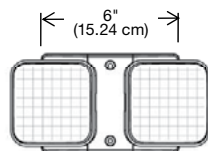

**Ordering format – LCARDSQLED Series**

Series	Head style / Lamp type	Options
LCAR	D= Double	SQLED= Thermoplastic square LED head

**Example: LCARDSQLED**

### ELF612D/LED Series

Thermoplastic square LED outdoor remote heads



**Housing**

- ELF612D/LED remote series is multi-volt 3.6, 6 or 12V, 3W total
- Thermoplastic housing and aluminum canopy with fully adjustable LED heads
- Suitable for outdoor application
- Suitable for wet location applications
- Wall or ceiling mount
- Available only in gray or black, single or double head configuration

**Approvals**

- UL924 Listed

**Warranty** (subject to proper installation and maintenance)

Three-year full warranty

**Dimensions**

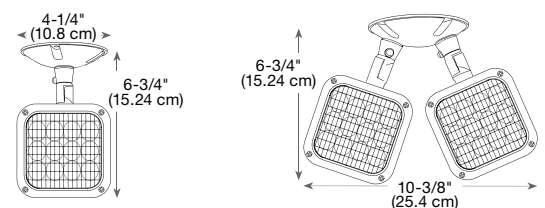

**Ordering format – ELF612D/LED Series**

Series	Options	Color
ELF612= Single ELF612D= Double	/LED= Thermoplastic square LED head	Blank= Gray -Bk= Black

**Example: ELF612D/LED**

## Cluster™ LED Round Head UQLXN500-2LED Series

Thermoplastic LED combination unit



### Cluster™ LED Family



Quick™ QLX & QLXN Exit series PG. 40-41

Cluster™ LED LCA-2LEDR Unit & ELF652D Remote Head Series PG. 86-87

ELF652D/LED Remote head PG. 86

ELF652D/LED-WP Remote head PG. 86

### Construction

- UV stabilized thermoplastic body
- Fully adjustable and reversible Cluster™ LED glare-free heads
- 6 inch EXIT lettering legend, available in red or green
- Universal faces (2 faceplates, 1 backplate)
- Field selectable chevrons

### Mounting

- Surface mount
- Canopy included for ceiling mount applications
- Universal J-Box mounting finishes

### Type of battery

3.6V Nickel-Cadmium battery

### Lamp Head Source

White LED 3.6V-4W, with life expectancy 50,000+ hours

### Electronics

- Optional Improved Diagnostics
- 120/277 60Hz

### Approvals

- UL 924 listed
- Damp location (50F to 104F)
- UL 94, 5VA flame rated

**Warranty** (subject to proper installation and maintenance)

Three-year full warranty

Detailed warranty terms located on [page 197](#) or online at: [www.lightalarms.com](http://www.lightalarms.com)



### Power consumption chart

Series	Current (A) / Power (W)	
	120VAC, 60Hz	277VAC, 60Hz
UQLXN500R-2LEDR	0.044/3.56	0.037/4.06
UQLXN500G-2LEDR	0.042/3.2	0.036/3.8

### Photometric performance

Spacing center-to-center (feet)	Spacing center-to-center (feet)	
	7 feet mounting height	15 feet mounting height
	15'	4'

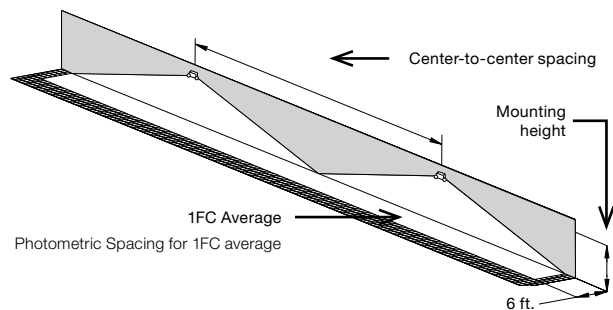



**Dimensions** (Dimensions are approximate and subject to change):

**Combination unit**

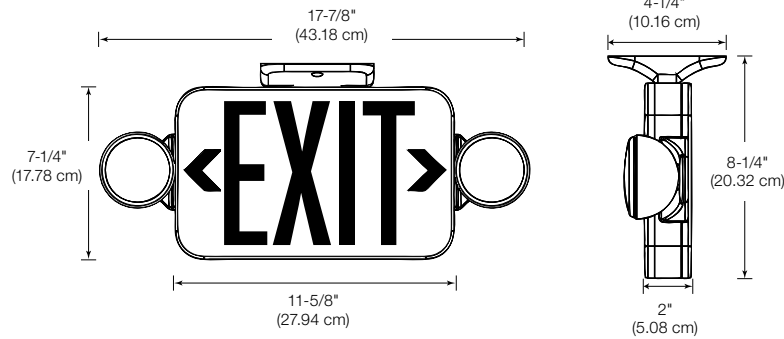

**Ordering format – UQLXN500-2LED**

Series	Legend color	Lamp	Capacity	Color
<b>UQLXN500</b>	<b>R=</b> Red <b>G=</b> Green	<b>-2LED=</b> Cluster™ LED head style	<b>Blank=</b> No Option <b>R=</b> Remote capacity¹ <b>RID=</b> Remote capacity and Improved Diagnostics¹	<b>Blank=</b> Mist-white <b>B=</b> Black

**Example: UQLXN500R-2LEDR**

¹ Remote capacity can only be used to power the ELF652D/LED or ELF652D/LED-WP remote fixtures or to extend the battery units emergency run time beyond the standard 90 minutes.

**ELF652D/LED Series**

Indoor remote head



**ELF652D/LED-WP Series**

Outdoor remote head



The Cluster™ LED ELF652D/LED Remote head can ONLY be powered from the UQLXN-2LED combo or LCA 2LED battery units of the same family. Used for internal or external applications, the indoor remote head draws 3.6V-3.6W and Weather-Proof head draws 3.6V-3.8W

**Dimensions**

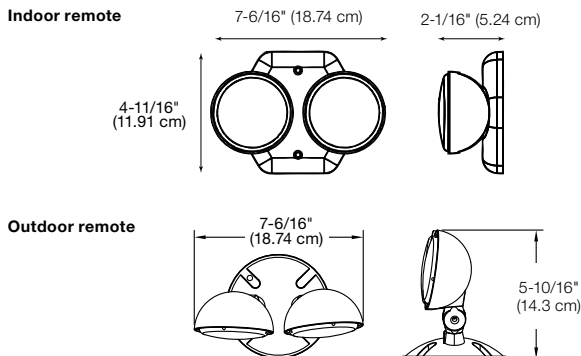

**Photometric performance**

Spacing center-to-center (feet)	
7 feet mounting height	15 feet mounting height
15'	4'

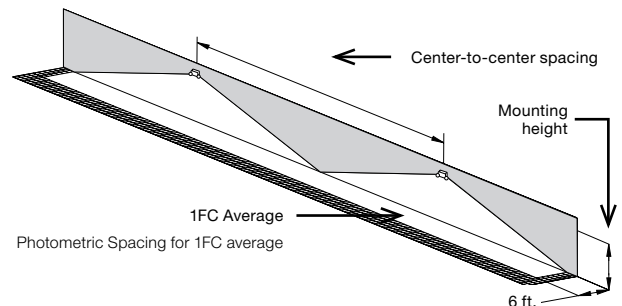

**Ordering format**

Series	Number of heads	Lamp	Option
<b>ELF652</b>	<b>D=</b> Double head	<b>/LED=</b> Cluster™ LED head style	<b>Blank=</b> Indoor use only <b>-WP=</b> Weather-proof

**Example: ELF652D/LED**

## Severe™ XV & XVE Series

NEMA-4X, vandal resistant and harsh environment exit sign



The Severe™ XV Series exit sign is a part of the Severe™ family of NEMA-4X rated emergency lighting products. The Severe™ family offers complete emergency lighting solutions for commercial and industrial environments where protection against humidity, dust, water infiltration and the risk of vandalism are specification criteria. These products deliver state-of-the-art illumination in a visually appealing package.

### Construction

- Full gasketed NEMA-4X housing
- Frame: polyvinyl chloride enclosure, fully gasketed around the lens, backplate and canopy to prevent water infiltration
- Faceplate: heavy-duty, vandal-resistant polycarbonate
- Backplate: heavy aluminum
- Comes with both Phillips head and tamper-proof screws
- 6 inch EXIT lettering legend, available in red or green
- Field-selectable chevrons
- Choice of finishes: white, black or gray

### Mounting

- Surface mount applications
- Ceiling and wall mount are NEMA-4X
- End and pendant mount are not NEMA-4X
- Canopy included for end or ceiling mount applications
- Universal J-box mounting
- ½ inch conduit entry on top and sides

### Special Wording Panels

Available. Contact your sales representative with your design requirements

### Housing/Face color



Black

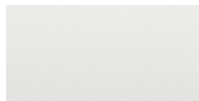

White



Gray



Aluminum

### The Severe™ NEMA-4X Rated and NSF Certified Family



Severe™ XV12E & XV24E  
Combo series  
PG. 50-51



Severe™ V  
Battery unit  
PG. 102-103



Severe™ ELF650  
Remote series  
PG. 137

### Electronics

- Magnetically operated test switch
- Standard Improved Diagnostics (non-audible)
- Optional Nexus®Pro IoT monitoring system
- Optional Nexus® wired and wireless monitoring system
- 120/277 60Hz
- Compatible with Lightalarms Mini Inverters (contact your sales representative for more information)

### Approvals

- UL 924 listed
- UL listed for wet and damp location self-powered (50°F to 104°F), AC and ACDC(-40°F to 104°F)
- Self-powered model UL listed for cold weather option (-4°F to +104°F)
- Meets NFPA101 (Life Safety Code), NFPA 70 NEC, OSHA illumination standards
- E-California Energy Commission Title 20

**Warranty** (subject to proper installation and maintenance)

Five-year limited warranty

Detailed warranty terms located on [page 197](#) or online at: [www.lightalarms.com](http://www.lightalarms.com)

nexus™ NEMA-4X



Nexus®Pro

**Dimensions** (Dimensions are approximate and subject to change):

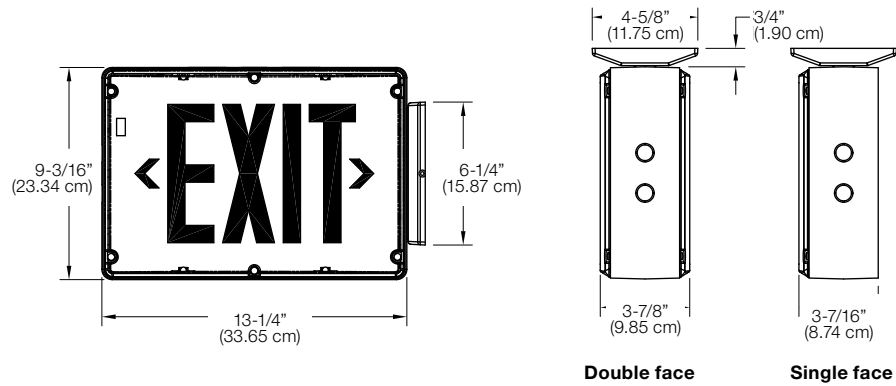

**Power consumption chart**

Model	AC Specs	DC Specs
AC-Only	120-277VAC, 50/60Hz (1.2W)	-
AC/DC	120-277VAC, 50/60Hz (1.2W)	6 to 24VDC (Less than 1.5W)
Self-Powered	120-277VAC, 50/60Hz (3.7W)	Ni-Cd battery (Min. 90 minutes)

**Accessories** (Order as a separate item)

Description	Product code
Convert single face to double face, red (in the field)	DFKR-*
Convert single face to double face, green (in the field)	DFKG-*
Tamper-Proof Bit (extra)	690.0454-L

\*Specify White (WT) or Black (BK) housing

**Ordering format**

Housing/ Face color	Series	Faces	Legend color	Diagnostic	Housing	Options
<b>Blank</b> = Black/Black	<b>XV</b> = AC-only	-1= Single face	-R= Red	<b>Blank</b> = AC-Only models	<b>-4X</b> = NEMA-4X	<b>Blank</b> = No options
<b>BW</b> = Black/White	<b>XVE</b> = Self-	-2= Double face	-G= Green	<b>-D</b> = Improved Diagnostics	housing <sup>2</sup>	<b>-2</b> = Dual Circuit
<b>BA</b> = Black/Aluminum	powered			(non-audible, standard) <sup>1</sup>		(120/120 or 277/277AC only) <sup>3</sup>
<b>GB</b> = Gray/Black	Nickel-			<b>-NEX</b> = Nexus <sup>®</sup> wired <sup>1</sup>		<b>-DC</b> = AC/DC 6V to 24VDC <sup>3</sup>
<b>GW</b> = Gray/White	Cadmium			<b>-NEXP</b> = Nexus <sup>®</sup> Pro IoT <sup>1</sup>		<b>-CW</b> = Cold weather (Self-Powered
<b>GA</b> = Gray/Aluminum	battery			<b>-NEXRF</b> = Nexus <sup>®</sup> wireless <sup>1</sup>		-4°F to 104°F) <sup>4</sup>
<b>WB</b> = White/Black						<b>-Y</b> = Open face/special wording
<b>WW</b> = White/White						<b>-CM</b> = Pendant mount
<b>WA</b> = White/Aluminum						

**Example: BAXVE-1-R-D-4X-CW**

<sup>1</sup> Available with Self-Powered models only  
<sup>2</sup> Wall or ceiling mount only  
<sup>3</sup> Not available with -NEX or -NEXRF, Nexus<sup>®</sup> option  
<sup>4</sup> Not required with AC model

## Severe™ XV12E & XV24E Combination Series

NEMA-4X, vandal resistant and harsh environment combination unit



### Construction

- Full gasketed NEMA-4X housing
- Faceplate: heavy-duty, vandal-resistant polycarbonate
- Backplate: heavy-duty aluminum
- Heads protected by clear polycarbonate lens
- Comes with both Phillips head and tamper-proof screws
- 6 inch EXIT lettering legend, available in red or green
- Field-selectable chevrons
- Choice of finishes: white, black or gray

### Lamp type

Choice of MR16 LED lamp voltages and wattages

### Mounting

- Surface mount
- Canopy included for end or ceiling mount applications
- Universal J-box mounting
- ½ inch conduit entry on top and sides

### Choice of battery

- XV12E model, Nickel-Cadmium battery, 6V-12W total battery capacity
- XV24E model, Nickel-Cadmium battery, 12V-24W total battery capacity

### Special Wording Panels

Available. Contact your sales representative with your design requirements

### Frame/Face plate color

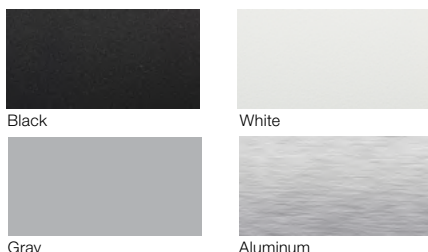

Black

White

Gray

Aluminum

### The Severe™ NEMA-4X Rated and NSF Certified Family



Severe™ XV exit series  
PG. 48-49



Severe™ V battery unit  
PG. 102-103



Severe™ ELF650 remote series  
PG. 137

### Electronics

- Magnetically operated test switch
- Standard Improved Diagnostics (non-audible)
- Standard 15 minutes time delay
- Optional Nexus®Pro IoT monitoring system
- Optional Nexus® wired and wireless monitoring system
- 120/277 60Hz

### Approvals

- UL 924 listed
- UL listed for wet and damp location  
50°F to 104°F (10°C to 40°C)
- UL listed for cold weather option -40°F to +104°F  
(-40°C to +40°C)
- Meets NFPA101 (Life Safety Code), NFPA 70 NEC, OSHA illumination standards

**Warranty** (subject to proper installation and maintenance)

Five-year limited warranty

Detailed warranty terms located on [page 197](#) or online at: [www.lightalarms.com](http://www.lightalarms.com)

nexus NEMA-4X NSF id improved diagnostics UL Nexus®Pro

### Photometric performance

Lamp	Spacing center-to-center (feet)	
	7 feet mounting height	15 feet mounting height
LD1	39'	34'
LD2	74'	57'
LD7	49'	39'
LD9	68'	54'
LD10	89'	80'

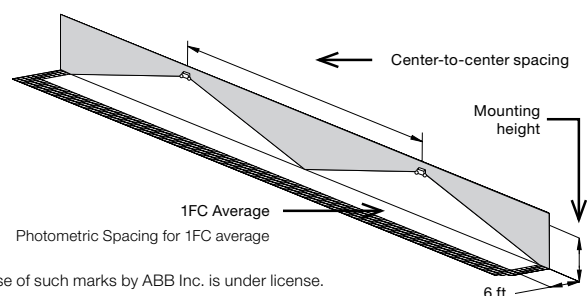

**Dimensions** (Dimensions are approximate and subject to change):

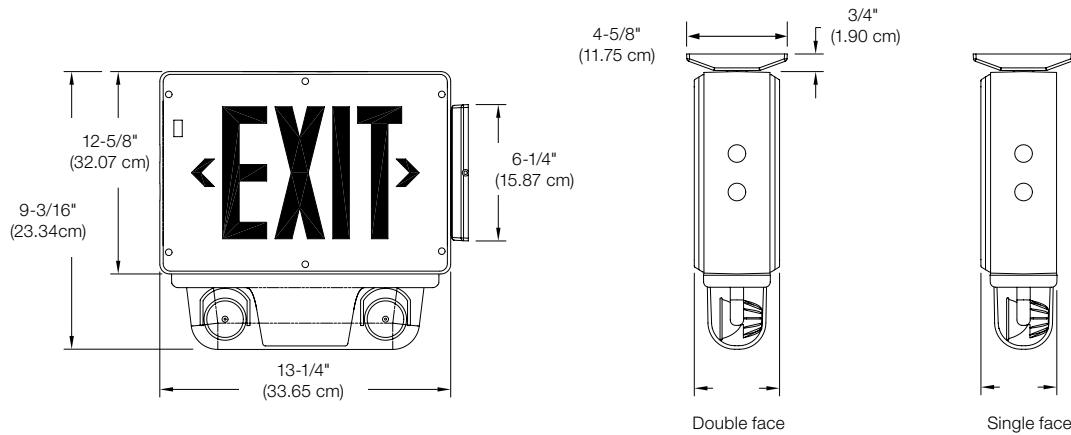

**Power consumption chart & unit rating**

Series	AC Specs			DC Specs				
	AC Input	Current Draw	Voltage	Battery	Battery capacity in watts			
					1-1/2 Hrs.	2 Hrs.	3 Hrs	4 Hrs
XV12E	120/277VAC, 50/60Hz	0.12/0.06A (Less than 13W)	6V	Nickel-Cadmium	12	9	-	-
XV24E		0.17/0.08A (Less than 19W)	12V		24	18	12	9
Models with CW4 Option		0.24/0.12A (Less than 25W)						

**Accessories** (Order as a separate item)

Description	Product code
Tamper-Proof Bit (extra)	690.0454-L

**Ordering format**

Housing/ Face color	Series/ Capacity	Faces	Legend color	Diagnostic
<b>Blank</b> = Black/ Black	<b>XV12E</b> = 6V-12W	-1= Single face	<b>R</b> = Red	<b>D</b> = Improved Diagnostics (non-audible, standard)
<b>BW</b> = Black/White	<b>XV24E</b> = 12V-24W	-2= Double face	<b>G</b> = Green	<b>DA</b> = Improved Diagnostics (audible)
<b>BA</b> = Black/ Aluminum				<b>NEX</b> = Nexus® wired
<b>WW</b> = White/ White				<b>NEXP</b> = Nexus® Pro IoT
<b>WB</b> = White/ Black				<b>NEXRF</b> = Nexus® wireless
<b>WA</b> = White/ Aluminum				
<b>GA</b> = Gray/Aluminum				
<b>GW</b> = Gray/White				
<b>GB</b> = Gray/Black				

Housing	# of heads	Lamp type	Options
-4X= NEMA-4X housing	/0= 0 head <sup>1</sup> /2= Two heads	<b>MR16 LED</b> LD1= 6V-4W LD2= 6V-5W LD7= 12V-4W LD9=12V-5W LD10=12V-6W	-208V= 208VAC, 60Hz input -240V= 240VAC, 60Hz input -208V50HZ= 208VAC, 50Hz input -CW4= Cold weather 120/277V (-40°F/-40°C) <sup>2</sup> -CM= Canopy Pendant Mount

**Example: WWXV12E1RDA4X/2M6CW4**

<sup>1</sup> A remote load must be connected  
<sup>2</sup> Single face only

## Severe™ XVHZ & XVEHZ Series

Class I Division 2, Groups A, B, C and D, hazardous location exit sign



### Severe™ Class I, Division 2 Family



Severe™ XVH Combo series  
PG. 54-55



Severe™ VH Battery unit  
PG. 112-113



Severe™ ELF651  
Remote series PG. 140-141

#### Construction

- Fully gasketed housing frame
- Faceplate: heavy-duty, vandal-resistant polycarbonate
- Backplate: heavy-duty aluminum
- Stainless steel tamper-proof screws
- 6 inch EXIT lettering legend, available in red or green
- Field-selectable chevrons

#### Mounting

- Surface mount
- Junction box included for wall, end or ceiling mount applications
- 1/2 inch conduit knock-out entry on top and sides.

#### Special Wording Panels

Available. Contact your sales representative with your design requirements

#### Electronics

- Magnetic test switch
- Standard Improved Diagnostics (non-audible)
- Optional Nexus® monitoring system
- 120/277 60Hz
- Compatible with Lightalarms Mini Inverters (contact your sales representative for more information)

#### Approvals

- CSA-US (To UL 924 standards)
- Evaluated to the UL 844 standard for Class I Division 2, Groups A, B, C and D
- NEC, OSHA and NEMA compliant for Class I Division 2, Groups A, B, C and D
- Self-powered model damp and wet location 50°F to 104°F (10°C to 40°C)
- AC/DC model -40°F to 104°F (-40°C to 40°C)
- Meets NFPA101 (Life Safety Code), NFPA 70-NEC and OSHA illumination standards
- E-California Energy Commission Title 20

#### Warranty (subject to proper installation and maintenance)

Five-year limited warranty

Detailed warranty terms located on **page 197** or online at: [www.lightalarms.com](http://www.lightalarms.com)



**Dimensions** (Dimensions are approximate and subject to change):

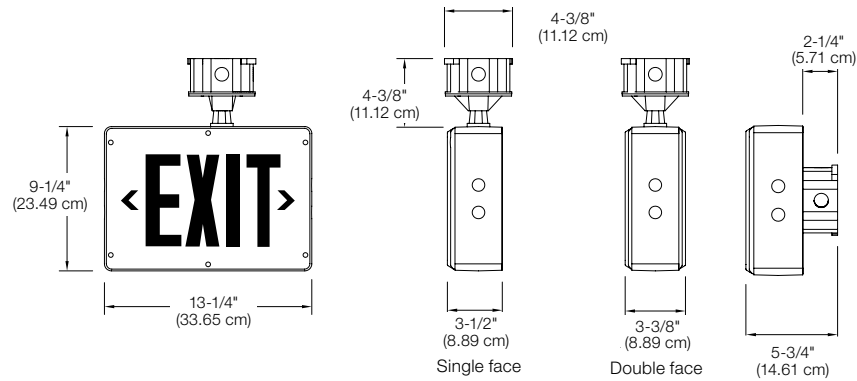

**Power consumption chart**

Model	AC Specs	DC Specs
AC/DC red	120-277VAC (Less than 2W)	6-24 VDC
AC/DC green	120-277VAC (Less than 1.5W)	6-24 VDC
Self-powered red	120-277VAC (Less than 2W)	Nickel-cadmium battery (Min. 90 mins.)
Self-powered green	120-277VAC (Less than 2.5W)	Nickel-cadmium battery (Min. 90 mins.)

**Accessories** (Order as a separate item)

Description	Product code
Tamper-Proof Bit (Extra)	690.0454-L

**Ordering format**

Housing/ Face color	Series	Faces	Legend color	Diagnostic	Options
<b>GG</b> = Gray/Gray	<b>XVHZ</b> = AC/DC <b>XVEHZ</b> = Self-Powered	<b>1</b> = Single face <b>2</b> = Double face	<b>R</b> = Red <b>G</b> = Green	<b>Blank</b> = AC/DC Models <b>-D</b> = Improved Diagnostics (included standard non audible) <sup>1</sup> <b>-NEX</b> = Nexus® Wired <sup>1</sup> (consult your sales representative) <b>-NEXRF</b> = Nexus® Wireless <sup>1</sup> (consult your sales representative)	<b>CW</b> = Cold weather -4°F to +104°F (-20°C to +40°C) <sup>1</sup>

**Example: GGXVEHZ2R-DCW**

<sup>1</sup> Available with Self-Powered models only

## Severe™ XVH & XVH12N Combination Series

Class I Division 2, Groups A, B, C and D hazardous location combination unit



### Severe™ Class I, Division 2 Family



Severe™ XVHZ & XVEHZ Exit series  
PG. 52-53



Severe™ VH  
Battery unit  
PG. 112-113



Severe™ ELF651  
Remote series  
PG. 140-141

#### Construction

- Fully gasketed housing frame
- Faceplate: heavy-duty, vandal-resistant polycarbonate
- Backplate: heavy-duty aluminum
- Vandal-resistant UV stabilized polycarbonate lamp cover
- Stainless steel tamper-proof screws
- 6 inch EXIT lettering legend, available in red or green
- Field-selectable chevrons

#### Mounting

- Surface wall mount
- Backplate features universal knockouts for a standard 4 inch junction box, and four mounting eyelets used in wall mount applications
- 1/2 inch conduit entry on top and sides

#### Lamp type

- Choice of MR16 LED lamp voltages and wattages

#### Battery type

- XVH Model, Nickel-Cadmium battery, 6V-20W total battery capacity
- XVH12N Model, Nickel-Cadmium battery, 12V-24W total battery capacity

#### Special Wording Panels

Available. Contact your sales representative with your design requirements

#### Photometric performance

Lamp	Spacing center-to-center (feet)	
	7 feet mounting height	15 feet mounting height
LD1	39'	34'
LD2	74'	57'
LD7	49'	39'
LD9	68'	54'
LD10	89'	80'

#### Electronics

- Magnetic test switch
- Standard Improved Diagnostics (non-audible)
- Optional Nexus® monitoring system
- 120/277 60Hz

#### Approvals

- CSA-US (to UL 924 standards)
- Evaluated to the UL 844 Standard for Class I Division 2, Groups A, B, C and D
- NEC, OSHA and NEMA compliant for Class I Division 2, Groups A, B, C and D
- Damp and wet location 50°F to 104°F (10°C to 40°C)
- Meets NFPA101 (Life Safety Code), NFPA 70-NEC and OSHA illumination standards
- Temperature code T4A

#### Warranty (subject to proper installation and maintenance)

- Five-year limited warranty

Detailed warranty terms located on [page 197](#) or online at: [www.lightalarms.com](http://www.lightalarms.com)

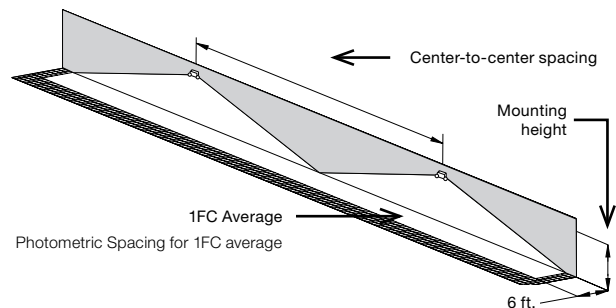



**Dimensions** (Dimensions are approximate and subject to change):

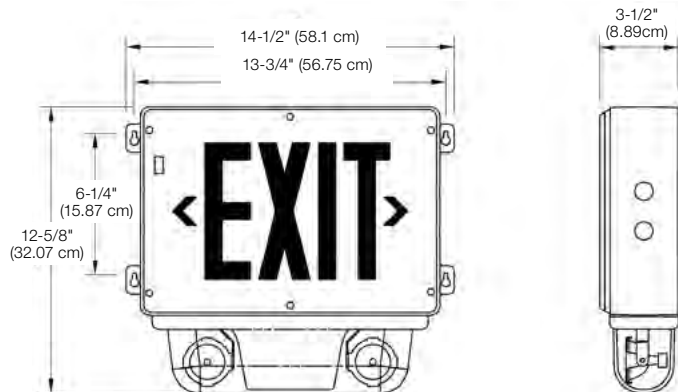

**Power consumption chart**

Series	AC input		Maximum		Stand-By		Watts to 87.5% of rated battery voltage <sup>1</sup>			
	(VAC)	Current (Amp)	Power (Watt)	Current (Amp)	Power (Watt)	1-1/2hrs	2 hrs	3 hrs	4 hrs	
XVH	120/277VAC, 50/60Hz	0.15 / 0.07	16	0.09 / 0.03	8	20	15	-	-	
XVH12N	120/277VAC, 50/60Hz	0.30 / 0.08	29	0.13 / 0.05	10	24	18	12	-	

<sup>1</sup> National Electrical Code Specification

**Accessories** (Order as a separate item)

Description	Product code
Tamper-Proof Bit (Extra)	690.0454-L

**Temperature codes**

Lamp rating	Temperature code	Maximum Temperature	Replacement lamp part #
6V-4W LED	T4A	248°F (120°C)	580.0097
6V-5W LED	T4A	248°F (120°C)	580.0122
12V-4W LED	T4A	248°F (120°C)	580.0093
12V-5W LED	T4A	248°F (120°C)	580.0104
12V-6W LED	T4A	248°F (120°C)	580.0106

Note: Use qualified replacement lamps to avoid risk of over-heating

**Ordering format**

Housing/ Face color	Series	Legend color	Diagnostic	No. of heads	Lamp type
<b>GG</b> = Gray/Gray	<b>Nickel-Cadmium battery</b> XVH= 6V-20W XVH12N= 12V-24W	<b>R</b> = Red <b>G</b> = Green	<b>D</b> = Improved Diagnostics (included standard non audible) <b>DA</b> = Improved Diagnostics (audible) <b>NEX</b> = Nexus® wired (consult your sales representative) <b>NEXRF</b> = Nexus® wireless (consult your sales representative)	<b>/0</b> = No head <sup>1</sup> <b>/2</b> = 2 heads	<b>LD1</b> = 6V-4W MR16 LED <b>LD2</b> = 6V-5W MR16 LED <b>LD7</b> = 12V-4W MR16 LED <b>LD9</b> = 12V-5W MR16 LED <b>LD10</b> = 12V-6W MR16 LED

**Example: GGXVHR-D2LD1**

<sup>1</sup> A remote load must be connected

## X402 LED AC-ONLY, AC/DC LED Exit Sign

Class I, Division 1 & 2, Groups C and D. Class II, Division 1 & 2, Groups E, F and G, Class III



### The EXP Family



### Construction

- Heavy-duty 20 gauge steel, baked enamel grey finish
- 6 inch EXIT lettering legend, available in red or green
- Field-selectable chevrons

### Mounting

- Ceiling, wall or pendant
- 3/4 inch conduit entry

### Approvals

- CSA-US (to UL 924 standards)
- Class I, Division 1&2, Groups C and D
- Class II, Division 1&2, Groups E, F and G
- Class III
- Complies with NEC, OSHA and NEMA for above classes and groups
- Suitable for wet and damp location
- Temperature code T6

**Warranty** (subject to proper installation and maintenance)

**Five-year full warranty**

Detailed warranty terms located on **page 197** or online at: [www.lightalarms.com](http://www.lightalarms.com)

### Transfer panel (to order separately with AC/DC exit signs)

- A transfer panel is only required for AC/DC hazardous location X402 exit signs that are under constant operation as required by code. Transfer panels are not designed to be installed/mounted in a hazardous or explosive area. Transfer panels are to be mounted remotely from these types of areas.
- Transfer panel available for up to 100W
- To order a transfer panel the following information is required:
  - 1) AC input: 120V or 277V
  - 2) DC voltage
  - 3) The total load wattage of all X402 lamp(s) to be supplied by transfer panel

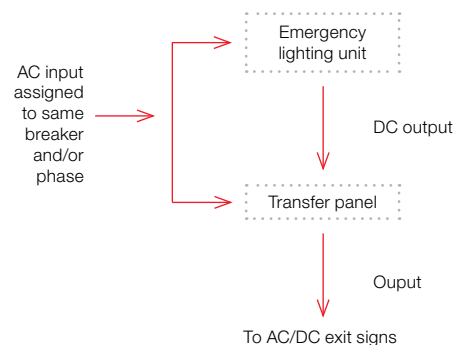

**Dimensions** (Dimensions are approximate and subject to change):

**AC-Only and AC/DC Exit signs**

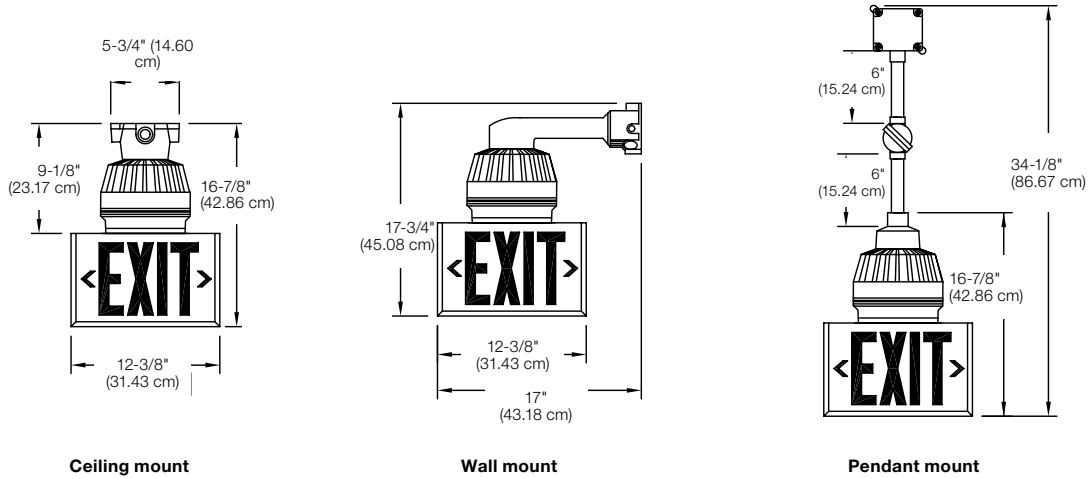

**Power Consumption**

120/277VAC, 60 Hz maximum 0.3/0.15A

**Ordering format – AC-Only or AC/DC exit sign face**



Faces	Series	Mounting	Lamp	Legend color
Blank= Single face 2= Double face	X402= Exit series	C= Ceiling P= Pendant W= Wall	LED6= 6V-3W LED <sup>1</sup> LED12= 12V-3W LED <sup>1</sup> LED24= 24V-3W LED <sup>1</sup> LED120= 120V-5W LED <sup>2</sup>	R= Red G= Green

**Example: AC-Only or AC/DC Exit sign: X402CLE6R**

<sup>1</sup> For AC/DC Exit  
<sup>2</sup> For AC only Exit

**Ordering format – Transfer panel (Required for the operation of AC/DC exit sign)**

AC voltage	DC voltage	Series	Watts	Version
120= 120V AC 277= 277V AC	-6= 6V DC <sup>1</sup> -12= 12V DC -24= 24V DC	-TS	-25= 25W -50= 50W -75= 75W -100= 100W	-LA

**Example: Transfer Panel (needed for AC/DC operation): 120-12-TS-25**

<sup>1</sup> 50W maximum

## EXP LED Series

Class I, Division 1 & 2, Groups C and D. Class II, Division 1 & 2, Groups E, F and G, Class III



### Housing

- One-piece heavy gauge, corrosion resistant, copper-free cast aluminum
- Consists of a housing with provisions for up to two fixtures
- Spin-off gasketed cover prevents propagation of internally generated arcs
- Stainless steel vent/drain
- Lighting fixtures are heavy cast aluminum with Pyrex® lens
- Exit faceplate: heavy-duty 20 gauge steel, baked enamel grey finish
- 6 inch EXIT lettering legend, available in red or green
- Field-selectable chevrons

### Mounting

- Surface wall mount
- 3/4" NPT conduit entry on top and bottom of housing
- Single and double pendant mount heads include elbow swivel, conduit extension pipe (6" increments)

### Electronics

- Pulse plus charger
- Low voltage disconnect
- Automatic brownout protection
- Battery lock-out
- Fused output circuit
- 120/277 60Hz

### Lamp type

- Heads offer a choice of MR16 LED lamp wattages
- Exit sign uses a 3 watt LED lamp

### Battery type

- 6V or 12V, Nickel-Cadmium battery



EXP6N & EXP12N  
Battery unit -  
see page 114-115

### Approvals

- CSA-US (To UL 924 standards)
- Manufactured in accordance with UL844, UL1203
- Class I, Division 1 & 2, Groups C and D
- Class II, Division 1 & 2, Groups E, F and G
- Class III
- NEC, OSHA and NEMA compliant for above Classes and Groups
- Temperature Code T6

**Warranty** (subject to proper installation and maintenance)

- Unit has a five-year warranty

Detailed warranty terms located on **page 197** or online at: [www.lightalarms.com](http://www.lightalarms.com)



### Photometric performance for lighting head

Lamp	Spacing center-to-center (feet)	
	7 feet mounting height	15 feet mounting height
2 X LD1	43'	29'
2 X LD2	70'	39'
2 X LD7	55'	36'
2 X LD9	67'	41'
2 X LD10	87'	62'

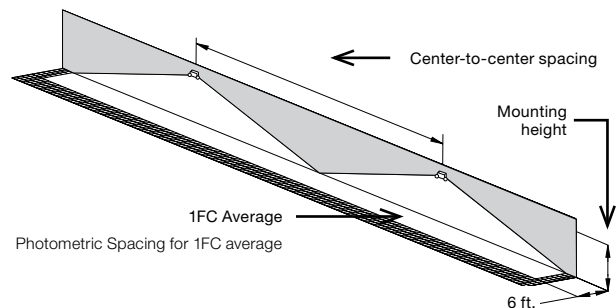

**Dimensions** (Dimensions are approximate and subject to change)

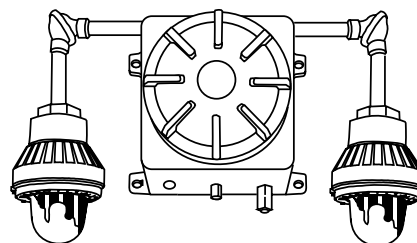

Housing: 12" X 12" X 9-1/2"  
Mounting Lugs: 10" and  
13-1/2" on center  
Overall dimensions  
(including fixtures): 38" X 38" X 10"

**Power consumption chart**

Series	Battery	Voltage	DC Specs				Units dual voltage <sup>1</sup>	AC Specs
			Battery capacity in watts <sup>1</sup>					
			90 Mins	2 Hrs	3 Hrs	4 Hrs		
EXP618	Nickel-Cadmium	6V	18	12	9	6	120/277VAC	0.55/0.25 A
EXP630		6V	30	20	15	10		
EXP1224		12V	24	18	12	9		
EXP1240		12V	40	30	20	15		

<sup>1</sup> All units 120/277 dual voltage, information based on wiring to specific voltage type

**Standard configurations for EXP6N and EXP12N Series**

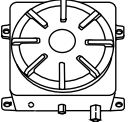
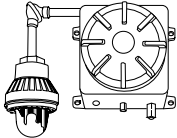
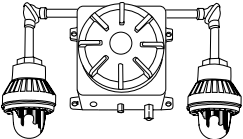
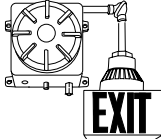
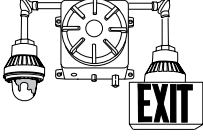
Unit	Catalog number	Description
	EXP618	6 Volt self contained hazardous location emergency battery unit 18 watts of remote capacity
Remote capability	EXP618-TS	6 Volt self contained hazardous location emergency battery unit 18 watts of remote capacity. Transfer switch included for use with remote Exit signs (maximum 5 Exits signs per TS)
	EXP1240E1LD9	12 Volt self contained hazardous location emergency battery unit with one head containing 2 X 12V 5W MR16 LED lamps, 30 watts of remote capacity
Single head emergency unit	EXP1240E1LD9-TS	12 Volt self contained hazardous location emergency battery unit with one head containing 2 X 12V 5W MR16 LED lamps, 30 watts of remote capacity. Transfer switch included for use with remote Exit signs (maximum 5 Exit signs per TS)
	EXP630E2LD1	6 Volt self contained hazardous location emergency battery unit with two heads, each containing 2 X 6V 4W MR16 LED lamps, 14 watts of remote capacity
Double head emergency unit	EXP630E2LD1-TS	6 Volt self contained hazardous location emergency battery unit with two heads, each containing 2 X 6V 4W MR16 LED lamps, 14 watts of remote capacity. Transfer switch included for use with remote Exit signs (maximum 5 Exit signs per TS)
	EXP618-TSX1-LR	6 volt self contained exit sign with 15 watts of remote capacity. Transfer switch included for use with integral exit sign and additional remote exit signs (maximum 5 exit signs per TS).
Self-powered exit sign		
	EXP1240-E1LD10-TSX1-LR	12 volt self contained combination unit with 25 watts of remote capacity. Transfer switch included for use with integral exit sign and additional remote exit signs (maximum 5 exit signs per TS).
Combination unit		

**Reflector/Guards**

Part #	Description
145.0016-L	Dome reflector
145.0017-L	Angle reflector
330.0125-L	Aluminum guard

**Ordering format**

Series	DC Voltage	Capacity	No. of heads and lamps	Lamp wattage/Type
EXP = Battery Unit/ Combo	6 = 6VDC 12 = 12VDC	18 = 18W (6V only) 30 = 30W (6V only) 24 = 24W (12V only) 40 = 40W (12V only)	Blank = No emergency head -E1= Single head, two lamps -E2= Two heads, two lamps each	LD1= 6V-4W, MR16 LED LD2= 6V-5W, MR16 LED LD7= 12V-4W, MR16 LED LD9= 12V-5W, MR16 LED LD10= 12V-6W, MR16 LED
Battery options	EXIT sign # of faces	EXIT sign lamp	EXIT sign letter color	
Blank= no transfer panel -TS= transfer panel (Required to supply remote exit sign only)	Blank= No exit sign X1= Single-face exit	Blank= no exit sign -L= LED exit sign	Blank= No exit sign R= Red G= Green	

**Example: EXP630-E1LD1-TSX1-LR**

## XT Tritium™ Self-Luminous Series

Non-electric, uses no electrical power internally or externally to illuminate



### Construction

- Housing and frame are made of ABS molding
- Faceplate lens is .13 thick acrylic
- Legend is non-glare polycarbonate
- Tamper-proof assembly with no removable fasteners
- 6" exit lettering legend, background available in red or green

### Mounting

- Surface mount
- Single face model includes (1) housing, (1) faceplate and (1) canopy
- Canopy included for wall, end or ceiling mount applications
- Double face model includes (2) housings, (2) faceplates and (1) canopy
- Canopy included for end or ceiling mount applications

### Finishes

- Choice of finishes: white, black or gray

### Chevrons

- Two field-selectable direction chevrons

### No power required

- Non-electric, uses no electrical power internally or externally to illuminate
- No wiring needed to operated
- No need to be illuminated by absorbing light from another source
- Spark-free, no filament, suitable for use in humid, corrosive or explosive environments

### Illumination

- Provided by phosphor-coated borosilicate tubes filled with tritium gas
- Low energy beta emission of tritium striking the phosphor coating inside the glass tubes generates illumination for the life of the sign

### Special wording panels

Not available

### Approvals

- NFPA Life Safety Code 101
- UL 924
- Approved for installation from -76°F to 212°F (-60°C to 100°C)
- City of Los Angeles
- State of California
- Council of American Building Officials (ICBO, SBCCI)
- OSHA
- USNRC
- ISO 9001

### Warranty (subject to proper installation and maintenance)

- Full warranty for life of sign
- 10-year sign= 10 full year warranty
- 20-year sign= 20 full year warranty

Detailed warranty terms located on **page 197** or **online at: [www.lightalarms.com](http://www.lightalarms.com)**

**Dimensions** (Dimensions are approximate and subject to change):

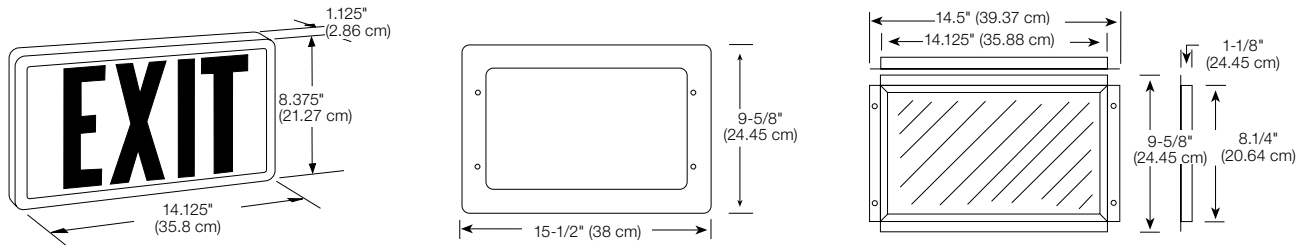

**Mounting**

**Single face signs**



Wall mount (flush wall or end)



Ceiling mount (flush ceiling)



Pendant mount

**Double face signs**



Wall mount (flush wall or end)



Ceiling mount (flush ceiling)



Pendant mount

**Accessories** (Order as a separate item)

Description	Product code
White pendant	PW-*
Black pendant	PB-*
Gray pendant	PA-*
Wire guard-wall mount	WG13-L
Wire guard-ceiling mount	WG5-L
Wire guard-end mount	WG15-L

\*Specify length of pendant (12", 24", 36" etc.)

**Ordering format**

Series	Sign life	Housing color	Legend color	Options	New
XT= Single face	10= 10 Years	W= Off white ABS frame	R= Red	-PC= Polycarbonate shield	-N= New version
2XT= Double face	20= 20 Years	B= Black ABS frame GY= Gray ABS frame A= Aluminum frame	G= Green		

**Example: XT10WR-N**

## Special wording panels

Customized special wording panels available for use in our exit signs and combination units



### Features

- The same sturdy construction and electrical design used in our exit signs and combination units, is used to produce our custom-worded, illuminated signage
- Sign bodies: steel, extruded and die-cast aluminum, weatherproof, flameretardant polycarbonate, high impact thermoplastic, recessed housing
- Custom wording: any style of lettering, any language, any alphabet, any special characters
- Graphics: logos, standard symbols, custom art
- Color choices: sign bodies, message, faceplate panel
- Contact your local Lightalarms® representative to discuss your specific requirements





Custom signage panels are available for use in the following series:

- Simplicity™ Premium Series page 14-15
- Simplicity™ Economizer Series page 18-19
- Genesis™ GX, GXE Series page 26-27
- Galaxy™ XD, XDN Series page 28-29
- Galaxy™ XDPC Series page 30-31
- UX4 LED Series page 34-35
- Grande™ Series page 36-37
- Grande™ Combination Series page 38-39
- Severe™ NEMA-4X Series page 48-49
- Severe™ NEMA-4X Combination Series page 50-51
- Severe™ Class I, Division 2 Series page 52-53
- Severe™ Class I, Division 2 Combination Series page 54-55
- X402, EXP and Combination Class I & II, Division 1&2 page 56-57

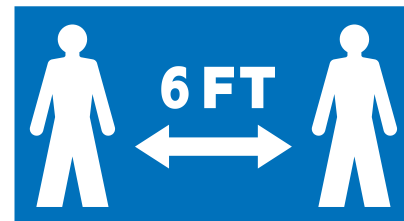

**Note:** Shown above are only a few examples of special wording panels that we have produced. Many more panels are available to meet any customized order.



#### BATTERY UNITS SERIES

Self-contained battery units are ideal for stand-alone use and for powering remote fixtures. Select from a range of capacities to provide the necessary power. Protective housings suit a variety of applications from commercial to heavy-duty industrial. High-performance lamps provide the necessary illumination at different mounting heights. Many battery units offer compatibility with the Nexus<sup>®</sup> system for automated testing and reduced maintenance.

# Table of contents

## Battery Units

					
<b>Introduction</b> About battery units & reference chart	<b>Architectural</b> <b>Recessed</b> <b>architectural</b> <b>RP Series</b>	<b>Architectural</b> <b>Vandal resistant linear</b> <b>dual-mode</b> <b>LSCN Series</b>	<b>Architectural</b> <b>Recessed mount</b> <b>Phantom™ Series</b>	<b>Architectural</b> <b>Recessed mount</b> <b>Mini-Phantom™</b> <b>Series</b>	<b>Architectural</b> <b>Recessed mount</b> <b>TBR Series</b>
66-69	70-71	72-73	74-75	76-77	78-79
					
<b>Architectural</b> <b>Recessed mount</b> <b>RD Series</b>	<b>Architectural</b> <b>Wall mount</b> <b>Protector™ Series</b>	<b>Commercial</b> <b>Surface mount</b> <b>LCAB-2SQLED</b> <b>Series</b>	<b>Commercial</b> <b>Cluster™ LED LCA-</b> <b>2LEDR Unit &amp; ELF652D</b> <b>Remote Head Series</b>	<b>Commercial</b> <b>Surface mount</b> <b>Grande™ Compact</b> <b>Series</b>	<b>Commercial</b> <b>Surface mount</b> <b>Grande™ Series</b>
80-81	82-83	84-85	86-87	88-89	90-91
					
<b>Architectural</b> <b>Surface mount indoor</b> <b>Camray™ LED</b> <b>Series</b>	<b>Commercial</b> <b>Surface mount</b> <b>MG/MN-SP Series</b>	<b>Commercial</b> <b>Surface mount</b> <b>MG &amp; MN Series</b>	<b>Commercial</b> <b>Surface mount</b> <b>PG, PQ, P12G &amp;</b> <b>P12Q Series</b>	<b>Industrial</b> <b>Surface mount</b> <b>S12E &amp; S24E Series</b>	<b>Industrial</b> <b>NEMA-4X &amp; NSF Rated</b> <b>Surface mount</b> <b>Severe™ Series</b>
92-93	94-95	96-97	98-99	100-101	102-103
					
<b>Industrial</b> <b>NEMA-4X</b> <b>Surface mount</b> <b>SP Series</b>	<b>Industrial</b> <b>NEMA-4X</b> <b>SPRL Series</b> <b>Surface mount</b> <b>Remote Fixture</b>	<b>Industrial</b> <b>NEMA-4X for</b> <b>Hazardous Location</b> <b>Surface mount</b> <b>SPH Series</b>	<b>Industrial</b> <b>NEMA-4X for</b> <b>Hazardous Location</b> <b>Surface mount</b> <b>SPHRL Remote</b> <b>Fixture Series</b>	<b>Industrial</b> <b>Hazardous Location</b> <b>Surface mount</b> <b>Severe™ VH Series</b>	<b>Industrial</b> <b>Hazardous Location</b> <b>Surface mount</b> <b>EXP6N &amp; EXP12N</b> <b>LED Series</b>
104-105	106-107	108-109	110-111	112-113	114-115
					
<b>Industrial</b> <b>Hazardous Location</b> <b>Surface mount</b> <b>EXP6N &amp; EXP12N</b> <b>LED Series</b>					
116-117					

# About Battery Units

## Emergency Battery Unit Equipment

Illumination provided by an emergency lighting battery life safety unit is one of the key elements to ensuring safety within a public building. In the event of a failure of the normal power supply, self-contained emergency lighting battery units automatically provide the illumination required to evacuate the building in a safe manner. Lightalarms® offers a wide selection of emergency lighting battery units to meet your demanding needs and requirements, whether it's for an architectural application or a Hazardous Location. With the many emergency lighting battery units available, the key is choosing the correct one to do the job. The appropriate Emergency Lighting Battery Unit will ensure that the proper emergency illumination is being provided. An emergency lighting battery unit is life saving equipment.

To select the correct Emergency Lighting Battery Unit, consider these 4 components: Housing, Circuitry, Battery, and Lamps.

1. **Housing:** Select a housing designed for the location where the unit will be installed; for example, indoors, outdoors, or in a vandal-prone or hazardous area.
2. **Circuitry:** The circuitry maintains the battery and allows the unit to be tested. Will standard circuitry meet your requirements, or does your application need self diagnostics or the state-of-the-art Nexus® system?
3. **Battery:** Lead-Calcium works best in controlled temperatures; and Nickel-Cadmium is for wider temperature ranges.
4. **Battery:** Lead-Calcium works best in controlled temperatures; and Nickel-Cadmium is for wider temperature ranges.

Select the proper emergency lighting battery unit for the specific application. Pick the proper lamps to provide the illumination needed to illuminate the area. Select the appropriate sized battery to provide DC power to illuminate the lamps for 90 minutes. Use the correct circuitry to maintain the battery and operate the lamps. To protect it all, use the proper housing for the environment where the emergency lighting battery unit will be located.

## Housing

The required housing construction of emergency lighting battery units depends on the location where the equipment is to be installed. Of all the components, the housing is the one most affected by the external environment. The housing plays many roles: it provides the fixture with a degree of protection against the environmental conditions, and meets technical, aesthetic and functional requirements. In general, non-residential lighting is divided in three market segments: commercial, institutional and industrial. This market segmentation still applies in the case of emergency lighting. Typically, the commercial and institutional sectors are more sensitive to costs and aesthetics, whereas the industrial sector is more influenced by technical aspects (fixture durability, etc.) of the product. Commercial spaces (stores, restaurants, hotels etc.) as well as institutions (schools, hospitals) are generally air-conditioned and have a controlled environment. When the equipment operates in normal temperature and humidity conditions, it typically only requires a NEMA1 rated housing with a Lead-Calcium battery. Industrial environments are the most severe and require rugged housing construction. Industrial housing types are defined by a number of parameters specific to various technical processes within the industry: temperature range, degree of humidity, degree of protection against water and dust, and resistance to corrosive chemicals, etc. requiring a NEMA-4X or higher rating.

## Emergency Lighting

### Battery units

#### Battery

The most important thing to consider when picking a battery is the temperature of the environment where the battery will be located. The ideal temperature for battery performance is 77°F. Cold temperatures affect the capacity, and hot temperatures affect the life of the battery. The temperature may affect the wattage size of the battery required. If you need a required amount of wattage to illuminate the lamp heads on the emergency lighting battery unit and the battery is in a cold area, that battery may not be able to deliver the required wattage needed for 90 minutes of operation. For example, at 32°F, a Lead-Calcium battery will be at approximately 75% of capacity; but, a Nickel-Cadmium battery will be at approximately 95% of capacity. If a battery is in a high temperature area, that battery may have a reduced life expectancy. For Lead-Calcium batteries every 15-20 degree increase in ambient temperature reduces the life of the battery by half (approximately).

#### Sealed Maintenance-Free Lead-Calcium: (Good)

**Design Feature:** Recombination technology. Does not gas externally under charging.

**Temperature Range:** 32°F -100°F

**Expected Life:** 4-8 years

**Warranty:** 3 years full warranty, 3 years pro rata warranty

#### Sealed Maintenance-Free Nickel-Cadmium: (Better)

**Design Feature:** High abuse battery, operates well in extreme temperatures.

**Temperature Range:** 0°F -131°F

**Expected Life:** 15 years

**Warranty:** 5 years full warranty, 7 years pro rata warranty

#### Sealed Maintenance-Free Nickel-Metal Hydride: (Best)

**Design feature:** Similar to Nickel-Cadmium, Environmentally Friendly, Cadmium-Free and Lead-Free

#### Lamp

Base the lamp choice for the emergency lighting battery unit on the lumen output of the lamp and the illumination required during an emergency situation. The sole purpose of an emergency lighting battery unit is to illuminate a path of egress in an emergency situation to evacuate people safely. Picking a lamp without enough lumen output will not provide a safe situation. If emergency lighting battery unit lamps are insufficient to illuminate the path of egress, the unsafe situation could lead to bodily injury or even death. The average illumination provided to a path of egress should be at least 1 ft-candle at floor level.

#### Hazardous Location Classifications

Hazardous areas are locations where the potential for explosion or fire exists due to the presence of certain gases, liquid vapors, or combustible dusts or fiber particles suspended in the air. The National Electrical Code®, NEMA, OSHA, UL, NFPA (Life Safety Standards), as well as State and Local codes, dictate the type of emergency lighting equipment to be used in different Hazardous Locations.

In Hazardous Locations, the emergency lighting equipment must be a type which will not itself contribute to the ignition of flammable or explosive substances present in the location. Lightalarms® offers emergency lighting equipment dedicated for use in Hazardous Locations.

**Class I (NEC-500-5)** Areas in which flammable gases or vapors may be present in sufficient quantities to be explosive or ignitable.

**Class II (NEC-500-6)** Areas made hazardous by the presence of combustible dust.

**Class III (NEC-500-7)** Areas in which there are easily ignitable fibers or flyings present, due to the type of material being handled, stored or processed-but in which such fibers or flyings are not likely to be in suspension in the air in quantities sufficient to produce ignitable mixtures.

**Division I (NEC-500-5, 6 & 7)** Normal Situation: A hazard is present in the everyday normal production operation or during frequent repair and/or maintenance activity.

**Division II (NEC-500-5, 6 & 7)** Abnormal Situation: Potentially hazardous material is expected to be safely contained within closed containers or closed systems, and will be present in the atmosphere only through accidental rupture, breakage, or abnormal operation.

**Group A, B, C & D (NEC-500-3)** Gases and vapors in Class I locations are classified into four groups: code A, B, C, and D. These materials are grouped according to the ignition temperature of the substance, its explosion pressure and other flammable characteristics.

**Groups E, F & G (NEC-500-3)** Combustible dust in Class II locations is classified according to ignition temperature and the conductivity of the hazardous substance.

## Emergency Lighting

### Battery units

#### Typical Class I locations:

- Industrial firms that use flammable liquids in dip tanks for parts cleaning or other applications.
- Petrochemical companies that manufacture chemicals from gas and oil.
- Dry cleaning plants where vapors from cleaning fluids can be present.
- Companies that have spraying areas where they coat products with paint or plastics.
- Aircraft hangars and fuel servicing areas.
- Utility gas plants, and operations involving storage and handling of liquified petroleum gas or natural gas

#### Typical Class II locations:

- Grain elevators, flour and feed mills.
- Plants that manufacture, use or store magnesium or aluminum powders.
- Plants that have chemical or metallurgical processes, producers of plastics, medicines, and fireworks etc.
- Producers of starch or candies.
- Spice grinding plants, sugar plants and cocoa plants.
- Coal preparation plants and other carbon handling or processing areas.

#### Typical Class III locations:

- Textile mills, cotton gins, cotton seed mills and flax processing plants.
- Clothing manufacturing plants.
- Any plant that shapes pulverizes or cuts wood and creates saw dust or shavings.

For more information consult the NEC Code.

#### NEMA Enclosures

- **Type 1** – Intended for use indoors primarily to prevent accidental contact of personnel with the enclosed equipment.
- **Type 2** – Intended for use indoors to protect the enclosed equipment against falling non-corrosive liquids and falling dirt.
- **Type 3** – Intended for use outdoors to protect the enclosed equipment against rain, windblown dust, sleet and external ice formation.
- **Type 3R** – Intended for use outdoors to protect the enclosed equipment against falling rain, sleet and external ice formation.
- **Type 4** – Intended for use indoors and outdoors to protect the enclosed equipment against windblown dust, rain, splashing water and hose-directed water.
- **Type 4X** – Intended for use indoors and outdoors to protect the enclosed equipment against windblown dust, rain, splashing water and hose-directed water; that provides an additional level of protection against corrosion.
- **Type 5** – Intended for indoor use primarily to protect against dust and falling dirt.
- **Type 6** – Intended for indoor or outdoor use primarily to provide a degree of protection against the entry of water during occasional temporary submersion at a limited depth.
- **Type 6P** – Intended for indoor or outdoor use primarily to provide a degree of protection against the entry of water during prolonged submersion at a limited depth.
- **Type 7** – Intended for use indoors in locations classified as Class I, Groups A, B, C, or D as defined in the National Electrical Code®.
- **Type 8** – Intended for indoor or outdoor use in locations classified as Class I, Groups A, B, C, & D as defined in the National Electrical Code®.
- **Type 9** – Intended for indoor locations classified as Class II, Groups E, F & G, as defined in the National Electrical Code®.
- **Type 10** – Enclosures are constructed to meet the applicable requirements of the Mine Safety and Health Administration.
- **Type 11** – Intended for indoor use primarily to provide, by oil immersion, a degree of protection to enclosed equipment against the corrosive effects of liquids and gases.
- **Type 12** – Intended for indoor use primarily to provide a degree of protection against dust, falling dirt, and dripping noncorrosive liquids.
- **Type 12K** – Enclosure with knockouts intended for indoor use primarily to provide a degree of protection against dust, falling dirt, and dripping non-corrosive liquids other than at knockouts.
- **Type 13** – Intended for indoor use primarily to provide a degree of protection against dust, spraying of water, oil, and noncorrosive coolant.

# Battery Units

## Quick reference chart

### Product description

	RP Series	LSCN Series	Phantom™ Series	Mini-Phantom™ Series	TBR Series	RD Series	Protector™ Series	LCA-2SQ Series	LCA-LEDR	Grande™ Compact Series	Grande™ Series	Camray® Series	MG/MIN-SP Series	MG & MN Series	PG, PQ, P12G + P12Q Series	S12E, S24E Series	Severe™ Series	SP Series	SPH Series	Severe™ VH Series	EXP6N & EXP12N Series	LCA-2RHL Series	
<b>Application</b>																							
Architectural	+	+	+	+	+	+						+											
Commercial	+	+					+	+	+	+	+		+	+	+								+
Industrial																+	+	+	+	+	+		
Recessed mount	+	+	+	+	+	+																	
Surface mount		+					+	+	+	+	+	+	+	+	+	+	+	+	+	+	+	+	+
Remote capacity					+	+	+	+	+	+	+		+	+	+	+	+	+				+	
Damp listed	+	+	+	+			+	+	+	+	+						+						
NEMA-4X																	+	+					
Hazardous locations																			+	+		+	
<b>Housing</b>																							
Thermoplastic	+	+					+	+	+	+	+												+
Steel	+		+	+	+	+							+	+	+	+							
Other materials												+					+	+		+	+		
<b>Battery</b>																							
Lead-Calcium	+		+	+	+	+	+	+		+	+	+	+	+	+	+	+	+		+			
Nickel-Cadmium	+		+	+	+	+					+		+	+			+	+				+	
Lithium	+	+																					+
Nickel-Metal Hybride	+		+	+					+	+		+											
<b>Color</b>																							
Mist-white	+	+	+	+	+	+	+	+	+	+	+	+	+	+	+	+	+	+					+
Black	+				+	+	+			+	+	+	+	+	+	+	+	+					
Gray												+				+	+	+		+	+		
Other colors												+											
<b>Lamp Options</b>																							
LED light source (not MR16)	+	+						+	+				+										+
MR16-LED	+		+	+	+	+	+			+	+		+	+	+	+	+				+		
<b>Available options</b>																							
Improved-Diagnostics	+	+	+	+	+	+	+	+	+	+	+	+	+	+	+	+	+	+		+			+
Photocell switch												+			+	+							
Time delay (15 min)	+		+	+	+	+				+	+	+	+	+	+	+		+			+		
Heater/Cold weather												+					+	+					
Vandal screws							+						+	+	+		+				+		
Lamp disconnect															+	+							
Cord & Plug										+			+	+	+	+							
<b>Accessories</b>																							
Wire guard							+	+		+		+	+	+	+						+		
Vandal shield							+	+															
Mounting shelf/platform													+	+	+	+							
Mounting bracket															+	+	+	+					
<b>Origin</b>																							
North America	+		+	+	+	+	+			+	+	+	+	+	+	+	+	+			+	+	

NOTE: This is a quick reference guide only. Refer to individual product pages for complete details regarding applicable models.

## RP Series

### Recessed architectural battery unit



#### Construction

- Thermoplastic rectangular fixture with additional round trim-plate, white finish
- All-metal backbox enclosure
- Optional black finish
- Fixed optics, optimized light distribution for ceiling heights up to 12 ft
- Four high-intensity LEDs with redundant connections; 140 lm/W, CCT 5000K

#### Options

- Standard unit 680 lumens
- Square distribution unit 717 lumens
- Plenum-rated enclosure
- Fixed, square light distribution pattern up to 12 ft. ceilings

#### Mounting

- Easily spring mounted in sheetrock ceilings
- Recessed installation in T-bar suspended ceilings



Remote test control

#### Electronics

- Infrared remote test control (up to 30ft)
- Self-test and diagnostic functions operated by micro-controller
- Two-wire universal AC input: 120 – 277VAC 50-60 Hz
- Battery full recharge in 24 hours
- 90 minutes of emergency lighting
- Optional time delay: 15 minutes
- Optional Nexus®Pro IOT emergency lighting central monitoring system
- Optional Power over Ethernet (requires a dedicated PoE switch supplied by an unswitched AC line)

#### Battery

- High-temperature rated lithium battery

#### Approvals

- Listed UL-924 for damp locations: 50° to 104°F (10° to 40°C)
- NSF-certified for splash non food zones
- Listed CEC Title 20
- BC - California Energy Commission Title 20

**Warranty** (subject to proper installation and maintenance)

Unit has a five-year limited warranty

Detailed warranty terms located [online at: www.lightalarms.com](http://www.lightalarms.com)

Nexus®Pro

#### Photometric performance

The RP Series has a fixed lighting distribution, optimized by design for ceiling heights up to 12 ft. The RP Series delivers a stable and optimal illumination easy to specify. Along an office corridor the space coverage ranges from 68 to 80 feet. The square distribution pattern covers a surface of more than 700 square feet.

**Table A: Standard unit 6-ft wide corridor<sup>1</sup>**

Mounting height	Lumens	Spacing center-to-center
9 ft	680	68 ft
10 ft		80 ft
12 ft		72 ft

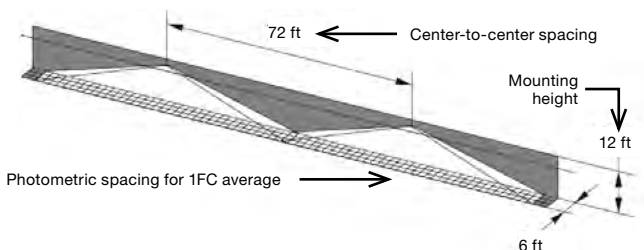

**Table B: Option “square distribution pattern” – single unit coverage<sup>1</sup>**

Mounting height	Lumens	Room size	Room surface
10 ft	717	27 ft x 27 ft	729 square feet

<sup>1</sup>Note: Illumination levels as per the Life Safety Code (NFPA 101): Average 1 fc, Minimum 0.1 fc, Max-to-min ratio 40:1. Typical reflectance levels of walls/ceiling/floor: 80/50/20.

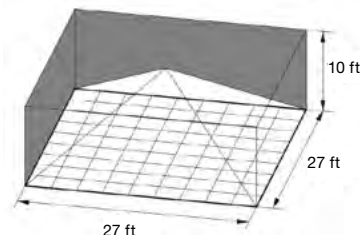



**Dimensions** (Dimensions are approximate and subject to change)

**Recessed suspended ceiling mount**

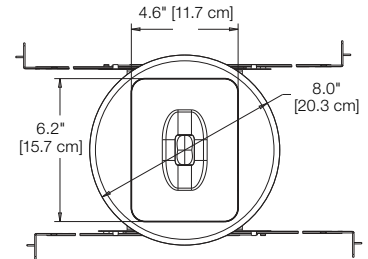
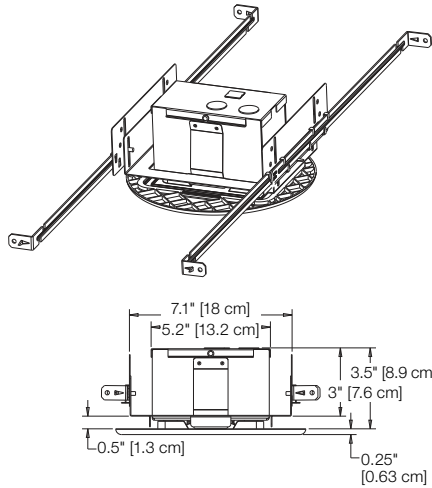
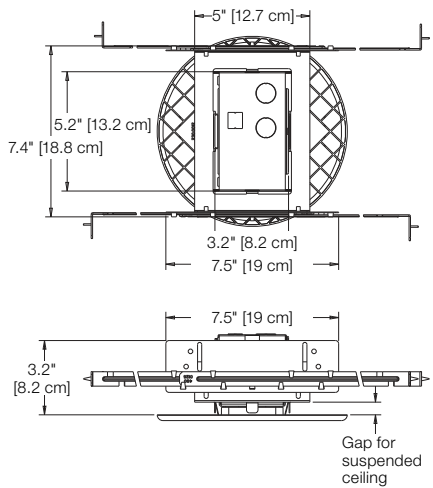

**Recessed sheetrock ceiling mount**

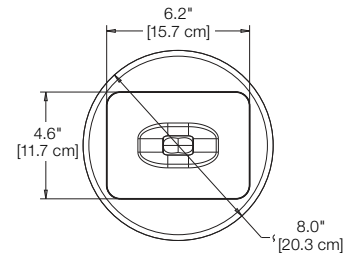
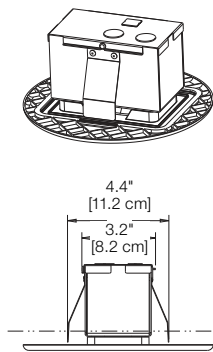
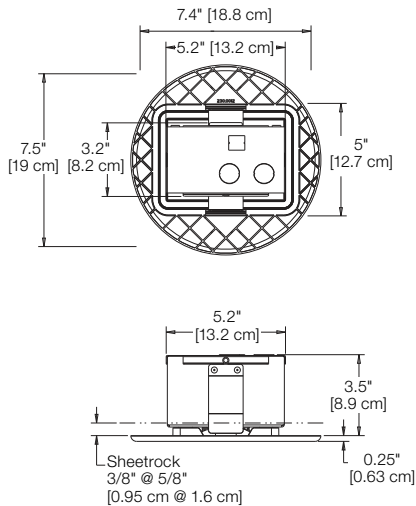

**Power consumption and unit rating**

AC	Maximum				Stand-by power (W)
	Input (VAC)	Current (A)	Power (W)	Power factor	
120	0.03	2.8	0.6	0.5	
277	0.02		0.5		

POE	Maximum		
	DC supply (V)	Current (A)	Power (W)
44 - 57	0.08	3	

**Ordering format**

Series	Color	Input	Unit type	Options
RP= Recessed plastic architectural	B= Black W= Factory white	Blank= 120 to 277VAC, 50/60Hz POE= Power over ethernet cable	Blank= standard charger D= Advanced diagnostics, non-audible NEXP= Nexus®Pro wireless bluetooth	Blank= No options D3= 15 minute time delay P= Plenum/Type IC rated SQ= Square distribution pattern

**Example: RPWPOEDD3**

## LSCN Series

Vandal resistant linear dual-mode battery unit



### Housing

- White high impact thermoplastic housing
- Frosted lens

### Mounting

- Standard surface ceiling and wall mount
- Optional accessory: semi-recessed ceiling mount

### LED information

- Easily adjustable LED strips for multiple beam angles
- Color temperature: 4000K
- 1200-1300 lumen output in emergency

### Electronics

- Dual-mode; normal lighting (field selectable) and emergency lighting
- Self-test and self-diagnostic
- Lithium-ion phosphate battery offering 120 minutes of emergency lighting
- Battery over/under charge protection
- Universal voltage 120V through 277Vac-60Hz

### Approvals

- Rated for 41°F to 113°F (5°C to 45°C)
- Suitable for wet locations
- Meets IP65 rating
- Meets IK10 rating requirements<sup>1</sup>
- ROHS compliant
- UL924 approved

### Warranty

(subject to proper installation and maintenance)

Unit has a three-year warranty

Detailed warranty terms located online at: [www.lightalarms.com](http://www.lightalarms.com)

<sup>1</sup>IK ratings refer to impact tests. IK10= Protected against 20 joules of impact (equivalent to 11lbs. of mass dropped from 16" high)



### Spacing

Mounting type	Spacing at 9ft mounting	Lumens
Ceiling mount	62'	1300
Wall mount	53'	1200

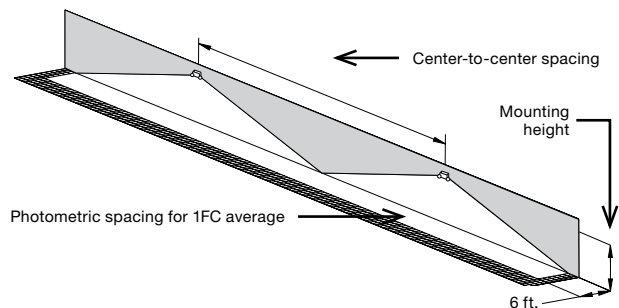

**Dimensions** (Dimensions are approximate and subject to change)

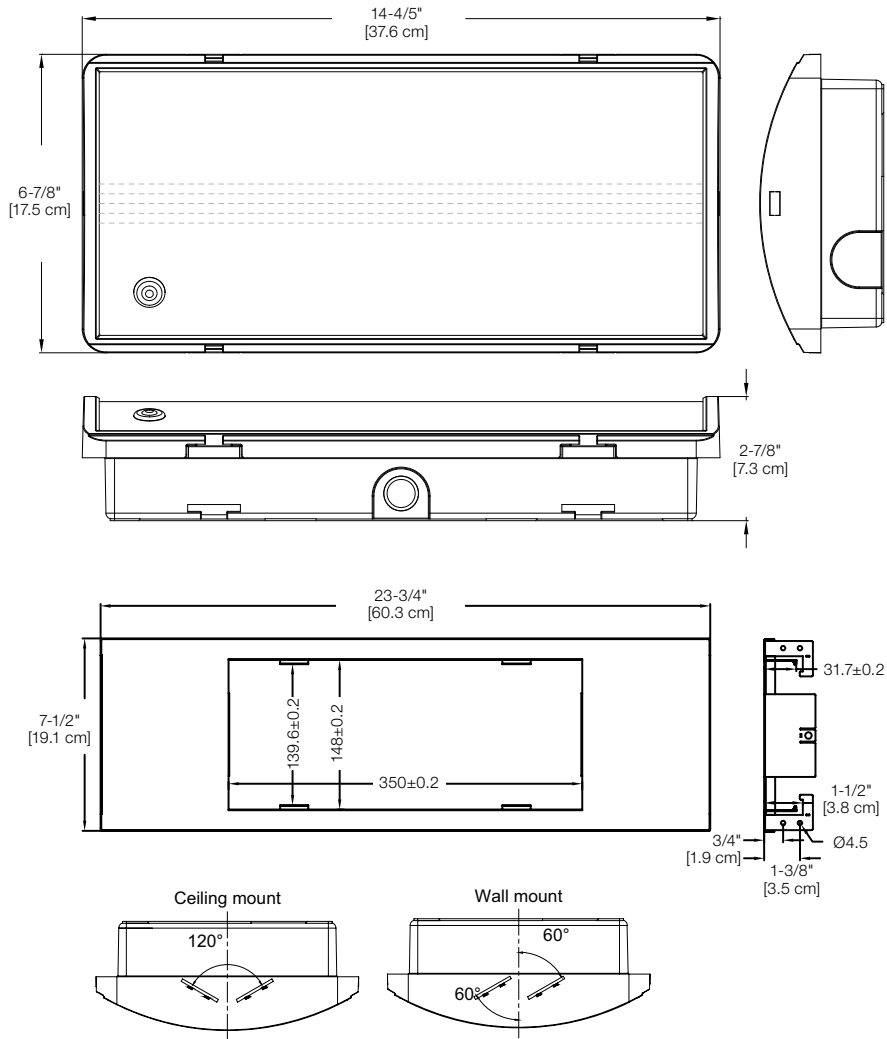

**Power consumption**

Status	Voltage	Wattage	Battery
Normal lighting	120-277 volt	16 watts	LifeP0 9.6 volt 3200mAh
Emergency lighting		14 watts	

**Accessories** (order as a separate item)

Description	Product code
Semi recessed mounting bracket	KIT-SR-LA

**Ordering format**

**Series**

**LSCN**= Linear battery unit

**EM**= Dual-mode: normal lighting and/or emergency lighting

**Example: LSCN-EM**

## Phantom™ Series

The unseen solution

12V up to 100w capacities – generator capable



### Housing

- Galvanized steel back-box
- Easy access to internal components
- Head assembly door and trim plate powder coated in a white finish
- Finish can be customized on site with paint or wallpaper
- Choice of various 12 volt MR16 LED lamp wattages
- Complete 360° head assembly door rotation
- Slip gear mechanism protects unit and objects against forcible stops

### Mounting

- Recessed mount into ceiling or wall with cavities
- Hanger bars included for lay-in installation in T-bar grid
- Can be installed on the wall stud or ceiling beam with simple, U-shape bracket
- Head assembly includes keyhole slot and quick-connect plugs for easy installation

### Electronics

- Pulse plus charger
- Low voltage disconnect
- Automatic brownout protection
- Battery lock-out
- Fused output circuit
- Optional: Improved Diagnostics
- 120/277 60Hz

### Choice of Sealed Maintenance-Free Battery

- 12V Lead-Calcium battery
- 12V Nickel-Cadmium battery

### Approval

- CSA-US (To UL 924 standards)
- New York City Approved
- BC – California Energy Commission Title 20

**Warranty** (subject to proper installation and maintenance)

Unit: five-year limited warranty

Detailed warranty terms located on **page 197** or online at: [www.lightalarms.com](http://www.lightalarms.com)

### Photometric performance

Lamp	Spacing center-to-center (feet)	
	7 feet mounting height	15 feet mounting height
LD7	49'	39'
LD9	68'	54'
LD10	89'	80'

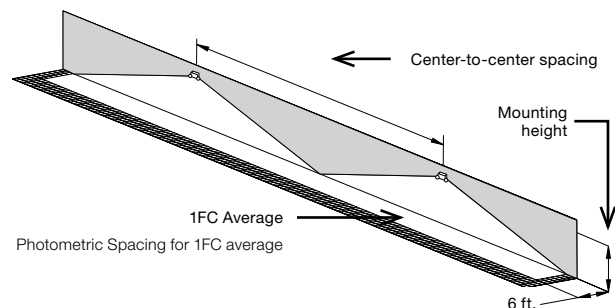

**Dimensions** (Dimensions are approximate and subject to change):

**Charger and battery compartment:**  
**For use in walls or ceilings with a cavity, not for use in block walls or solid ceilings.**

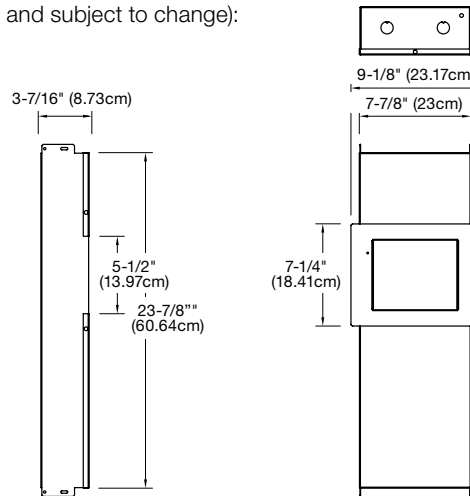

**Power consumption chart - Non-CEC models**

Series	Battery	Voltage	DC Specs				AC Specs			
			Battery capacity (in watts)				AC Input	Input current	Maximum Input power	Stand by Input Power
			90 Mins	2 Hrs	3 Hrs	4 Hrs				
PHN40	Nickel-Cadmium	12V	40	30	24	12	120V	0.25A	30W	0.79W
PHN70	Nickel-Cadmium	12V	70	50	40	24	277V	0.12A		
PHN100	Nickel-Cadmium	12V	100	70	50	40				

<sup>1</sup> Stand-by power consumption is 50% lower for Lead-Calcium Batteries

**Power consumption chart - CEC models**

Series	Battery	Voltage	DC Specs				AC Specs					
			Battery capacity (in watts)				Units dual voltage <sup>1</sup>	Current			Power	
			90 Mins	2 Hrs	3 Hrs	4 Hrs		Maximum	Stand by	Maximum	Stand by	
PHM40	Lead-Calcium	12V	40	30	24	12	120VAC	0.25A	0.10A	30W	11W	
PHM70	Lead-Calcium	12V	70	50	40	24	277VAC	0.12A	0.05A	30W	11W	
PHM100	Lead-Calcium	12V	100	70	50	40						

**Accessories** (Order as a separate item)

Description	Product code
Remote Test Switch (Metal Faceplate)	PSW
Remote Test Switch (Plastic Faceplate)	PSW-1

**Ordering format**

Series	Battery	Capacity	Number of heads	Lamp type	Options	Approval
<b>PH=</b> Battery unit	<b>M=</b> Lead-Calcium <b>N=</b> Nickel-Cadmium	<b>40=</b> 12V-40W <b>70=</b> 12V-70W <b>100=</b> 12V-100W	<b>-2=</b> Two lamps	<b>MR16 LED</b> (LD7)= 12V-4W (LD9)= 12V-5W (LD10)= 12V-6W	<b>Blank=</b> No Options <b>ID=</b> Improved Diagnostics (audible) <sup>1</sup> <b>IDNA=</b> Improved Diagnostics (non audible) <sup>1</sup> <b>DL=</b> Damp location <sup>2</sup> <b>X=</b> Back box shipped separate	<b>-CEC=</b> CEC Title 20 for California <sup>3</sup>

**Example: PHM100-2LD7**

<sup>1</sup> -ID & -IDNA include a time delay feature that can be enabled/ disabled in the field or set by the factory by including -ID-TD\* or -IDNA-TD\*

<sup>2</sup> -DL option not available with PHN100 unit

<sup>3</sup> Available with lead-calcium models only

Series	Input voltage	Number of heads	Lamp type	Options
<b>PHG=</b> Generator unit	<b>1=</b> 120VAC, 60Hz <b>2=</b> 277VAC, 60Hz	<b>-2=</b> Two lamps	<b>MR16 LED</b> (LD7)= 12V-4W (LD9)= 12V-5W (LD10)= 12V-6W	<b>DL=</b> Damp location <b>X=</b> Back box shipped separately

**Example: PHG1-2LD7**

## Mini-Phantom™ Series

The full retrofit unseen solution  
12V-40W capacities – generator capable

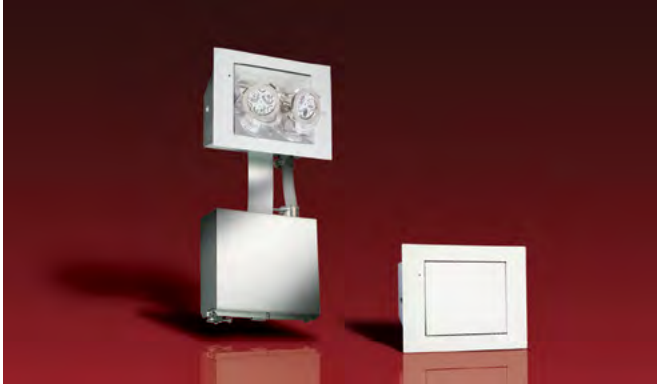

### Housing

- Galvanized steel back-box
- Easy access to internal components
- Head assembly door and trim plate powder coated in a white finish
- Finish can be customized on site with paint or wallpaper
- Choice of various 12 volt MR16 LED lamp wattages
- Complete 360° head assembly door rotation
- Slip gear mechanism protects unit and objects against forcible stops

### Mounting

- Recessed wall or ceiling with cavity mount (retrofit into finished wall)
- Designed to install into an 8-1/4" by 5-3/4" opening
- Key-hole slot for ease of installation

### Photometric performance

Lamp	Spacing center-to-center (feet)	
	7 feet mounting height	15 feet mounting height
LD7	49'	39'
LD9	68'	54'
LD10	89'	80'
5OH	160'	171'

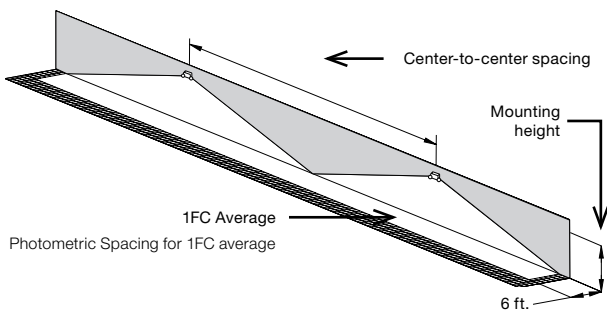

### Electronics

- Pulse plus charger
- Low voltage disconnect
- Automatic brownout protection
- Battery lock-out
- Fused output circuit
- Optional: Improved Diagnostics
- 120/277 60Hz

### Choice of Sealed Maintenance-Free Battery

- 12V Lead-Calcium battery
- 12V Nickel-Cadmium battery

### Approval

- CSA-US (To UL 924 standards)
- New York City Approved
- BC – California Energy Commission Title 20

### Warranty (subject to proper installation and maintenance)

Unit: five-year limited warranty

Detailed warranty terms located on [page 197](#) or online at: [www.lightalarms.com](http://www.lightalarms.com)



### Accessories (Order as a separate item)

Description	Product code
Remote test switch (Metal faceplate)	PSW
Remote test switch (Plastic faceplate)	PSW-1

**Dimensions** (Dimensions are approximate and subject to change):

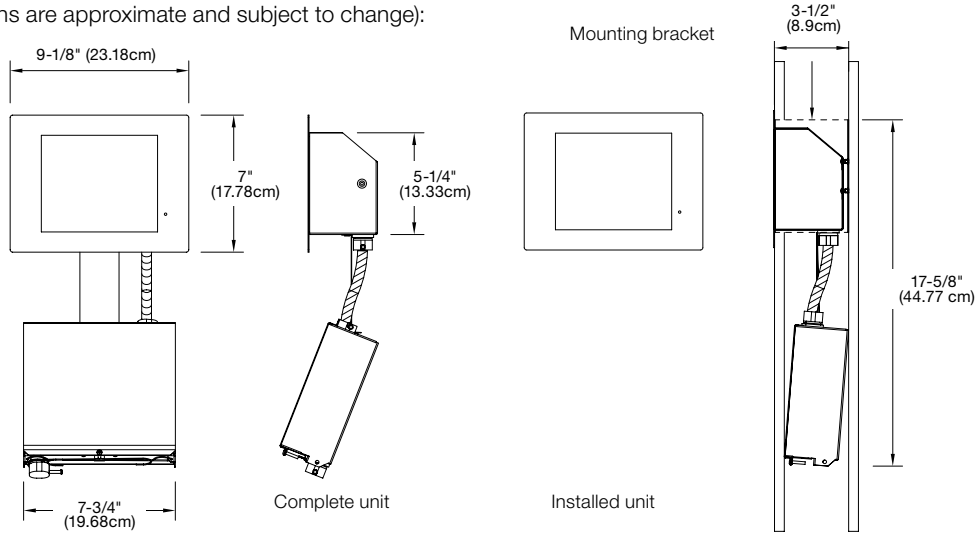

**Power consumption chart - Non-CEC models**

Series	Battery	Voltage	DC Specs						AC Specs			
			Battery capacity (in watts)				Units dual voltage <sup>1</sup>	Current		Power		
			90 Mins	2 Hrs	3 Hrs	4 Hrs		Maximum	Stand by	Maximum	Stand by	
MPHM40	Lead-Calcium	12V	40	30	24	12	120VAC	0.25A	0.25A	30W	11W	
MPHN40	Nickel-Cadmium	12V	40	30	24	12	277VAC	0.12A	0.05A	30W	11W	

<sup>1</sup> Stand-by power consumption is 50% lower for Lead-Calcium Batteries

**Power consumption chart - CEC models**

Series	Battery	Voltage	90 Mins	DC Specs				Units dual voltage <sup>1</sup>	Current		Power	
				Battery capacity (in watts)					Maximum	Stand by	Maximum	Stand by
				2 Hrs	3 Hrs	4 Hrs						
MRTM40	Lead-Calcium	12V	40	<b>30</b>	24	12	120VAC 277VAC	0.25A 0.12A	-	30W 30W	0.79W 0.79W	

<sup>1</sup> Maximum power when equipped with 2x 50W lamps

**Ordering format – Battery unit**

Series	Battery	Capacity	Number of heads	Lamp type	Options	Approval
<b>MPH</b>	<b>M</b> = Lead-Calcium <b>N</b> = Nickel-Cadmium	<b>40</b> = 12V-40W	<b>-2</b> = Two lamps	<b>MR16 LED</b> <b>(LD7)</b> = 12V-4W <b>(LD9)</b> = 12V-5W <b>(LD10)</b> = 12V-6W	<b>Blank</b> = No options <b>ID</b> = Improved Diagnostics (audible) <sup>1</sup> <b>IDNA</b> = Improved Diagnostics (non audible) <sup>1</sup> <b>DL</b> = Damp location <sup>2</sup>	<b>-CEC</b> = CEC Title 20 for California <sup>3</sup>

**Example: MPH40-2(LD7)DL**

<sup>1</sup> -ID & -IDNA include a time delay feature that can be enabled/ disabled in the field or set by the factory by including -ID-TD\* or -IDNA-TD\*

<sup>2</sup> Available on all models except Lead-Calcium

<sup>3</sup> Available with lead-calcium models only

**Ordering format – Generator**

Series	Input voltage	Number of heads	Lamp type	Options
<b>MPHG</b> = Generator unit	<b>1</b> = 120VAC, 60Hz <b>2</b> = 277VAC, 60Hz	<b>-2</b> = Two lamps	<b>MR16 LED</b> <b>(LD7)</b> = 12V-4W <b>(LD9)</b> = 12V-5W <b>(LD10)</b> = 12V-6W	<b>MR16 Halogen High Output</b> <b>(50H)</b> = 12V-50W

**Example: MPHG1-2(LD7)DL**

## TBR Series

Recessed steel housing



### Housing

- Steel housing
- Standard off-white finish, optional black finish
- Lighting heads, available in thermoplastic or decorative die-cast aluminum
- Choice of MR16 LED lamp wattages

### Mounting

- Fully recessed ceiling
- Hanger bars included for lay-in installation in t-bar grid

### Electronics

- Pulse plus charger
- Low voltage disconnect
- Automatic brownout protection
- Battery lock-out
- Fused output circuit
- Optional: Improved Diagnostics
- Optional: Nexus® monitoring system
- 120/277 60Hz

### Photometric performance

Lamp	Spacing center-to-center (feet)	
	7 feet mounting height	15 feet mounting height
LD1	43'	36'
LD2	81'	64'
LD7	55'	43'
LD9	71'	56'
LD10	100'	85'

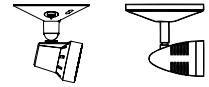

Available Head Style Choices:

ELF3

DR130

Head Style Suffix:

/E3

/D1

### Choice of Sealed Maintenance-Free Battery

- 6V or 12V Lead-Calcium battery
- 12V Nickel-Cadmium battery

### Approval

- UL 924 Listed
- New York City Approved

**Warranty** (subject to proper installation and maintenance)

Unit: five-year limited warranty

Detailed warranty terms located on [page 197](#) or online at: [www.lightalarms.com](http://www.lightalarms.com)

nexus

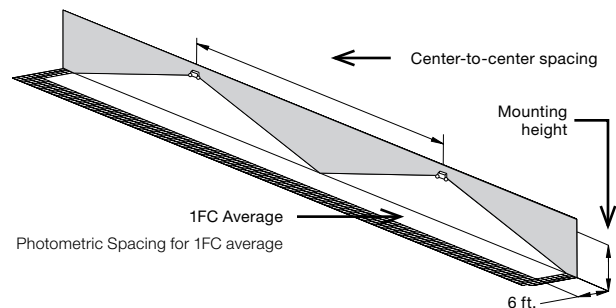



**Dimensions** (Dimensions are approximate and subject to change)

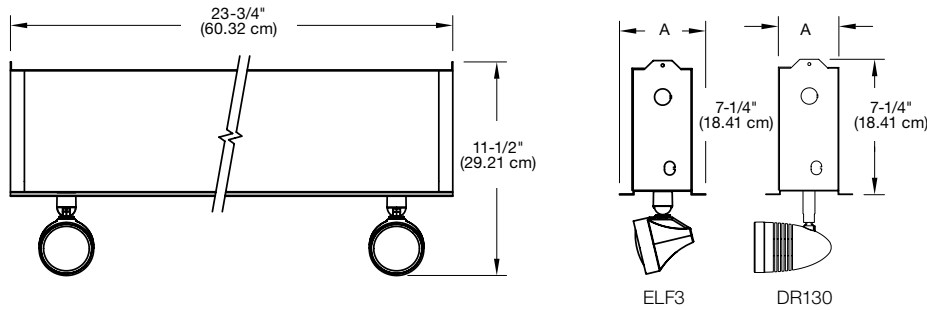

**Cabinet dimensions**

Units	Cabinet	A
54W and under	S	4-5/8"
81W and higher	L	7-1/8"

**Power consumption chart**

Series	Battery	Voltage	DC Specs				AC Specs	
			Battery capacity (in watts)				Units dual voltage <sup>1</sup>	Current Maximum
			90 Mins	2 Hrs	3 Hrs	4 Hrs		
TBRC0	Lead-Calcium	6V	18	12	0	0	120VAC 277VAC	0.3A 0.15A
T12BRC0	Lead-Calcium	12V	36	25	20	14		
T12BRC2	Ni-Cd with option (-N)	12V	50	31	25	18		

<sup>1</sup> All units 120/277 dual voltage, information based on wiring to specific voltage type

**Accessories** (Order as a separate item)

Description	Product code
Remote Test Switch (Metal Faceplate)	PSW
Remote Test Switch (Plastic Faceplate)	PSW-1

**Ordering format**

Number of heads	Series/Battery/Capacity	Head style	Lamp type	Options
<b>Blank</b> = No heads	<b>Lead-Calcium Battery</b>	<b>/E3</b> = ELF3 (MR16, Plastic)	<b>LD1</b> = 6V-4W MR16 LED	<b>Blank</b> = Mist white housing, no options
<b>2</b> = 2 heads	<b>TBRC0</b> = 6V-18W	<b>/D1</b> = DR130 (MR16, Metal)	<b>LD2</b> = 6V-5W MR16 LED	<b>-ID</b> = Improved Diagnostics (audible) <sup>1</sup>
<b>3</b> = 3 heads	<b>T12BRC0</b> = 12V-36W		<b>LD7</b> = 12V-4W MR16 LED	<b>-IDNA</b> = Improved Diagnostics (non audible) <sup>1</sup>
	<b>For Nickel-Cadmium Battery (must include option -N)</b>		<b>LD9</b> = 12V-5W MR16 LED	<b>-NEX</b> = Nexus <sup>®</sup> wired Compatible <sup>2</sup> (consult your sales representative)
	<b>T12BRC2</b> = 12V-50W		<b>LD10</b> = 12V-6W MR16 LED	<b>-NEXRF</b> = Nexus <sup>®</sup> wireless Compatible <sup>2</sup> (consult your sales representative)
				<b>-B</b> = Black housing
				<b>-TD15</b> = Time delay (15 minutes) <sup>3</sup>
				<b>-N</b> = Nickel-Cadmium battery

**Example: 2T12BRC0/D1LD9**

<sup>1</sup> -Minimum lamp load required: 20% of unit capacity. Not available with 100W N-Cd 24V. Should also apply to NEX and NERF.

<sup>2</sup> -NEX & -NEXRF is CSA-US approved only.

<sup>3</sup> -Time delay only available with ID, IDNA, NEX or NEXRF models

## RD Series

Recessed steel housing

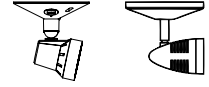

Available Head Style Choices: ELF3 DR130  
Head Style Suffix: /E3 /D1

### Housing

- Steel housing
- Standard off-white finish, optional black finish
- Lighting heads, available in thermoplastic or decorative die-cast aluminum
- Choice of MR16 LED lamp wattages

### Mounting

- Fully recessed ceiling or wall-mount
- Hanger bars included for lay-in installation in T-bar grid
- Suitable for sheet rock installation

### Electronics

- Pulse plus charger
- Low voltage disconnect
- Automatic brownout protection
- Battery lock-out
- Fused output circuit
- Optional: Improved Diagnostics
- 120/277 60Hz

### Photometric performance

Lamp	Spacing center-to-center (feet)	
	7 feet mounting height	15 feet mounting height
LD1	43'	36'
LD2	81'	64'
LD7	55'	43'
LD9	71'	56'
LD10	100'	85'

See lamp table

### Choice of Sealed Maintenance-Free Battery

- 6V or 12V Lead-Calcium battery
- 6V or 12V Nickel-Cadmium battery

### Approvals

- UL 924 listed
- New York City Approved

### Warranty (subject to proper installation and maintenance)

Unit: five-year limited warranty

Detailed warranty terms located on page 197 or online at: [www.lightalarms.com](http://www.lightalarms.com)

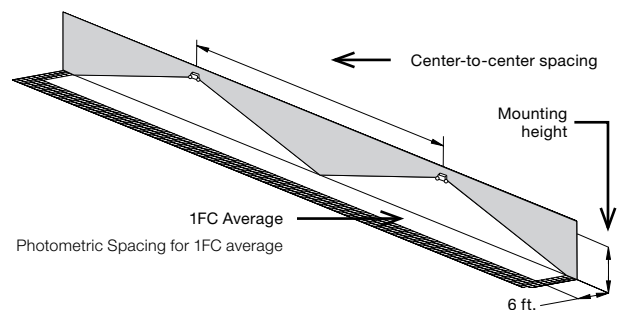

**Dimensions** (Dimensions are approximate and subject to change)

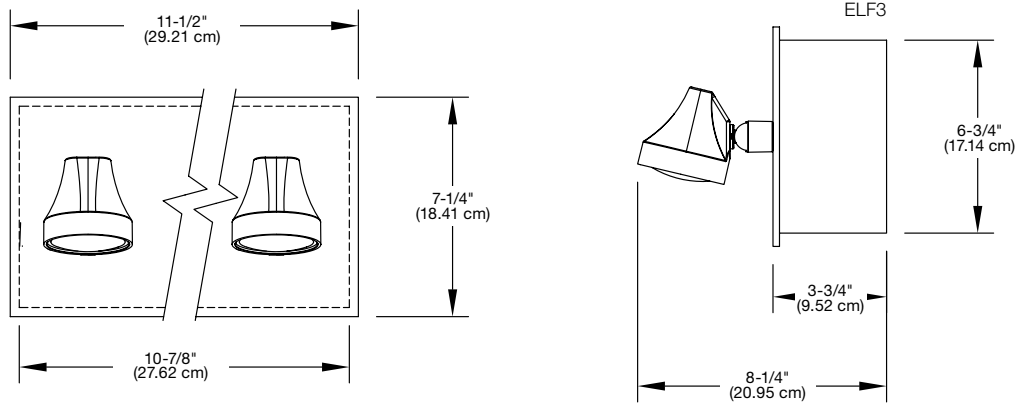

**Power consumption chart**

Series	Battery	Voltage	DC Specs				AC Specs	
			Battery capacity (in watts)				Units dual voltage <sup>1</sup>	Current Maximum
			90 Mins	2 Hrs	3 Hrs	4 Hrs		
RD6M1	Lead-Calcium	6V	18	12	0	0	120VAC 277VAC	0.3A 0.15A
RD12M3	Lead-Calcium	12V	36	25	20	14		
RD12C4	Nickel-Cadmium	12V	50	36	25	18		

<sup>1</sup> All units 120/277 dual voltage, information based on wiring to specific voltage type

**Accessories** (Order as a separate item)

Description	Product code
Wire Guard (DR130 or ELF3 heads)	WG6-L
Remote Test Switch (Metal Faceplate)	PSW
Remote Test Switch (Plastic Faceplate)	PSW-1

**Ordering format**

Number of heads	Series/Battery/Capacity	Head style	Lamp type	Options
<b>Blank</b> = No heads	<b>Lead-Calcium Battery</b>	<b>/E3</b> = ELF3 (MR16, Plastic)	<b>LD1</b> = 6V-4W MR16 LED	<b>Blank</b> = Mist white housing, no options
<b>2</b> = 2 heads	<b>RD6M1</b> = 6V-18W	<b>/D1</b> = DR130 (MR16, Metal)	<b>LD2</b> = 6V-5W MR16 LED	<b>-B</b> = Black Housing
	<b>RD12M3</b> = 12V-36W		<b>LD7</b> = 12V-4W MR16 LED	<b>-ID</b> = Improved Diagnostics (audible) <sup>1</sup>
	<b>Nickel-Cadmium Battery</b>		<b>LD9</b> = 12V-5W MR16 LED	<b>-IDNA</b> = Improved Diagnostics (non audible) <sup>1</sup>
	<b>RD12C4</b> = 12V-50W		<b>LD10</b> = 12V-6W MR16 LED	<b>-T3</b> = Time delay (15 minutes) <sup>2</sup>

**Example: RD12M3/DR130LD9-IDNA**

<sup>1</sup> Minimum lamp load required: 20% of unit capacity

<sup>2</sup> Time delay only available with ID or IDNA

## Protector™ Series

6V Thermoplastic housing  
protected LED lamp heads



### Housing

- White or black UV stabilized thermoplastic enclosure
- Clear polycarbonate lens covers

### Mounting

- Surface mount
- Universal J-box mounting

### Lamp Type

- MR16 LED Lamp, 6V-4W or 6V-5W

### Electronics

- Pulse plus charger
- Low voltage disconnect
- Automatic brownout protection
- Battery lock-out
- Fused output circuit
- Optional: Improved Diagnostics
- Optional: Nexus® monitoring system
- 120/277 60Hz

### Choice of Sealed Maintenance-Free Battery

- 6V Lead-Calcium battery

### Approval

- UL 924 Listed
- Damp location optional 50°F to 104°F (10°C to 40°C)
- BC – California Energy Commission Title 20

**Warranty** (subject to proper installation and maintenance)

Unit: five-year limited warranty

Detailed warranty terms located on [page 197](#) or online at: [www.lightalarms.com](http://www.lightalarms.com)



### Fast & easy installation

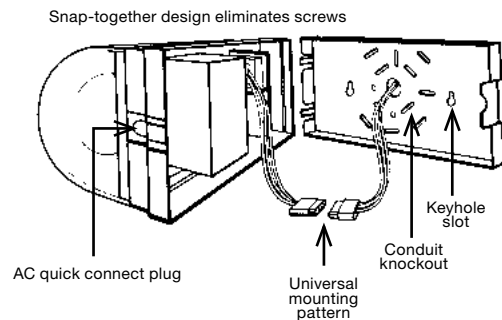

**Dimensions** (Dimensions are approximate and subject to change)

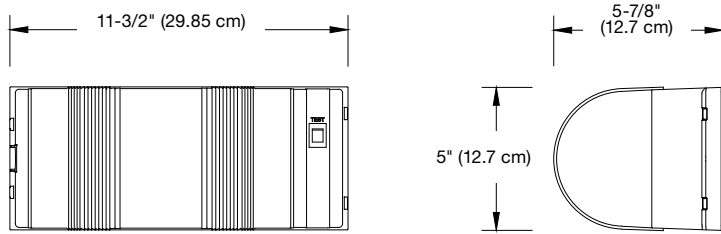

**Power consumption chart - Non-CEC models**

Series	Battery	Voltage	Battery capacity in watts			
			90 Mins	2 Hrs	3 Hrs	4 Hrs
2PT10	Lead-Calcium	6V	10	8	-	-
2PT18		6V	18	12	10	7

**Power consumption chart - CEC models**

Ac Input	Input Current	Maximum	Stand-by
		Input Power	Input Power
120VAC	0.10A	12W	0.72W
277VAC	0.05A		

**Accessories** (Order as a separate item)

Description	Product code
Additional special bit for tamper-proof screws	690.0454-L
Replacements lamps MR16 LED 6V-4W	580.0097-L
Replacements lamps MR16 LED 6V-5W	580.0122-L

**Ordering format**

Heads	Series	Lamp suffix	Unit type	Options	Approval
2= 2 heads	PT10= 6V-10.8W PT18= 6V-18W	LD1= 6V-4W MR16 LED LD2= 6V-5W, MR16 LED	Blank= Standard unit ID= Improved Diagnostics (audible) IDNA= Improved Diagnostics (non-audible) NEX= Nexus® wired <sup>1</sup> NEXRF= Nexus® wireless <sup>1</sup>	Blank= Mist white B= Black DL= Damp locations 68-86°F (20-30°C) VS= Vandal-resistant screws 3CP= Line cord 120V CM= Ceiling mount	-CEC= CEC Title 20 for California <sup>2</sup>

**Example: 2PT10LD1ID**

<sup>1</sup> Available with 2PT10 only

<sup>2</sup> Available with PT10-LA with ID, IDNA or NEXRF only

## LCAB-2SQLED Series

1W LED heads, thermoplastic 3.6V Nickel-Cadmium battery unit



### Housing

- UV stabilized thermoplastic body
- Two fully adjustable glare-free square lighting heads
- White finish

### Mounting

- Ceiling or wall mount
- Universal J-box mounting

### Lamp Type

Two 3.6V-1W LED heads total 200 lumens, CCT 6000K

### Options

Remote capacity for (2) ELF612/LED, (1) ELF612D/LED or (1) LCARDSQLED available with optional Improved Diagnostics

### Photometric performance

Lamp	Spacing center-to-center (feet)	
	7 feet mounting height	15 feet mounting height
LCAB	13'	4'
LCAR	13'	4'
ELF612	13'	4'

### Power consumption chart

Series	Battery	DC Specs		AC Specs
		Battery	Battery	Units dual voltage
LCAB-2SQLED	Nickel-cadmium		3.6V	120/277, 60Hz, 0.024A
LCAB-2SQLEDR			3.6V	120/277, 60Hz, 0.028A
LCAB-2SQLEDRID			3.6V	120/277, 60Hz, 0.028A

<sup>1</sup> All units 120/277 dual voltage, information based on wiring to specific voltage type

### Electronics

- Pulse plus charger
- Low voltage disconnect
- Automatic brownout protection
- Battery lock-out
- Fused output circuit
- Optional: Improved Diagnostics
- 120/277 60Hz

### Battery type

- 3.6V maintenance free rechargeable Nickel-Cadmium battery

### Approvals

- UL 924 listed
- Damp location 50°F to 104°F (10°C to 40°C)
- UL 94, 5VA flame rated

**Warranty** (subject to proper installation and maintenance)

Three-year full warranty

Detailed warranty terms located on **page 197** or online at: [www.lightalarms.com](http://www.lightalarms.com)

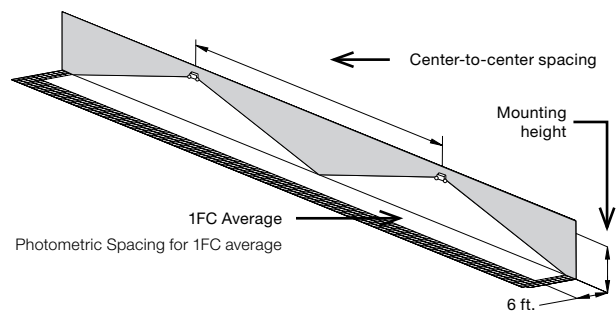

**Dimensions** (Dimensions are approximate and subject to change)

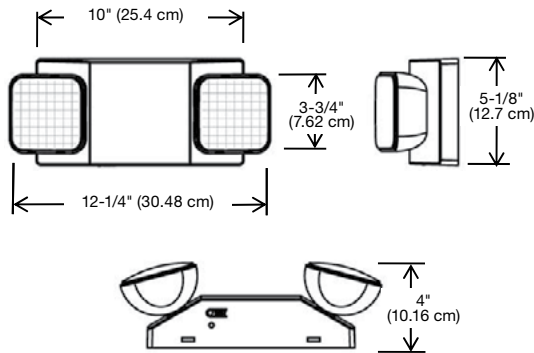

**Accessories** (Order as a separate item)

Description	Product code
Wire Guard	WG10-L
Vandal Resistant Shield	CPS
Vandal Resistant Shield (NEMA-4X)	CPS-4X
Replacement battery LCAB-2SQLED	022433-L
Replacement battery LCAB-2SQLEDR & LCAB-2SQ-LEDRID	2 X 022433-L

**Ordering format**

Series	Head style / Lamp type	Options
LCAB	2SQLED	<b>Blank</b> = No remote capacity <b>R</b> = 3W Remote capacity <sup>1</sup> <b>RID</b> = 3W Remote capacity and Improved Diagnostics <sup>1</sup>
<b>Example: LCAB2SQLEDRID</b>		

<sup>1</sup> To be used with the (2) ELF612D/LED, (1) ELF612D/LED or (1) LCARDSQLED.

**LCARDSQLED Series**

Thermoplastic square LED indoor remote heads



**Housing**

- Thermoplastic dual head remote
- Wall or ceiling mount

**Lamp information**

- LED 3.6V, 2W total
- 6000K LED color temperature

**Approvals**

- Damp location listed
- UL924 Listed

**Warranty** (subject to proper installation and maintenance)

Three-year full warranty

**Dimensions**

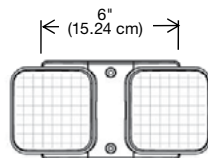

**Ordering format – LCARDSQLED Series**

Series	Head style / Lamp type	Options
LCAR	<b>D</b> = Double	<b>SQLED</b> = Thermoplastic square LED head
<b>Example: LCARDSQLED</b>		

**ELF612D/LED Series**

Thermoplastic square LED outdoor remote heads



**Housing**

- ELF612D/LED remote series is multi-volt 3.6, 6 or 12V, 3W total
- Thermoplastic housing and aluminum canopy with fully adjustable LED heads
- Suitable for outdoor application
- Suitable for wet location applications
- Wall or ceiling mount
- Available only in gray or black, single or double head configuration

**Approvals**

- UL924 Listed

**Warranty** (subject to proper installation and maintenance)

Three-year full warranty

**Dimensions**



**Ordering format – ELF612D/LED Series**

Series	Options	Color
<b>ELF612</b> = Single <b>ELF612D</b> = Double	<b>/LED</b> = Thermoplastic square LED head	<b>Blank</b> = Gray <b>-Bk</b> = Black
<b>Example: ELF612D/LED</b>		

## Cluster™ LED LCA-2LEDR Unit & ELF652D Remote Head Series

Offered in a family concept, with exit combination units and remote



### Housing

- UV stabilized thermoplastic body
- Fully adjustable Cluster™ LED glare-free heads
- Choice of white or black housing

### Mounting

- Ceiling or wall mount
- Universal J-box mounting

### Lamp Type

- White LED 3.6V-3.6W, with life expectancy 50,000+ hours, 70 lumens per head

### Electronics

- Pulse plus charger
- Low voltage disconnect
- Automatic brownout protection
- Battery lock-out
- Fused output circuit
- Optional: Improved Diagnostics
- 120/277 60Hz

### Photometric performance

Spacing center-to-center (feet)	
7 feet mounting height	15 feet mounting height
15'	4'

### Sealed Maintenance-Free Battery

3.6V Nickel-Cadmium battery

### Approvals

- UL 924 listed
- Damp location 50°F to 104°F (10°C to 40°C)
- UL 94, 5VA flame rated
- BC- California Energy Commission Title 20

**Warranty** (subject to proper installation and maintenance)

Three-year full warranty

Detailed warranty terms located on [page 197](#) or online at: [www.lightalarms.com](http://www.lightalarms.com)

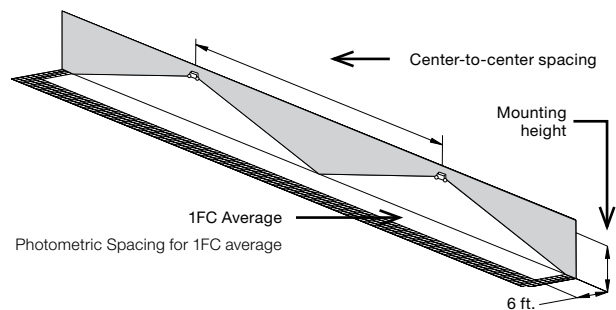



**Dimensions** (Dimensions are approximate and subject to change)

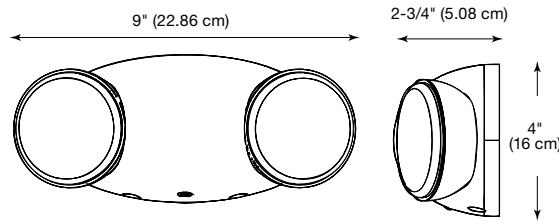

**Power consumption chart**

	AC Specs	DC Specs
Series	120VAC, 60Hz	277VAC, 60Hz
LCA-2LEDR	0.191/0.92	0.129/1.62

**Ordering format - Battery unit**

Series	Lamp	Capacity	Color
<b>LCA</b>	<b>-2LED=</b> Cluster LED head style	<b>Blank=</b> No Remote <b>R=</b> Remote capacity <sup>1</sup> <b>RID=</b> Remote capacity with Improved Diagnostics <sup>1</sup>	<b>Blank=</b> Mist-white <b>B=</b> Black
<b>Example: LCA-2LEDR</b>			

<sup>1</sup> Remote Capacity can ONLY be used to power the Cluster™ LED ELF652D Remote Head or the extend the battery units emergency run time beyond the standard 90 minutes.

**ELF652D/LED Series**  
Indoor remote head



**ELF652D/LED-WP Series**  
Outdoor remote head



The Cluster™ LED ELF652D/LED Remote head can ONLY be powered from the UQLXN-2LED combo or LCA 2LED battery units of the same family. Used for internal or external applications, the indoor remote head draws 3.6V-3.6W and Weather-Proof head draws 3.6V-3.8W

**Dimensions**

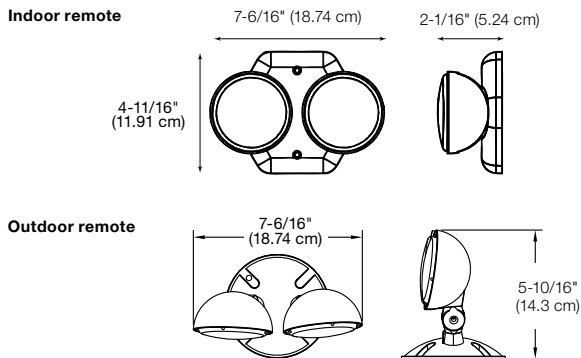

**Photometric performance**

Spacing center-to-center (feet)	
7 feet mounting height	15 feet mounting height
15'	4'

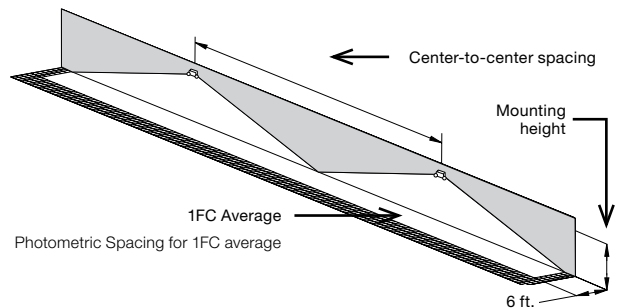

**Ordering format**

Series	Number of heads	Lamp	Option
<b>ELF652</b>	<b>D=</b> Double head	<b>/LED=</b> Cluster™ LED head style	<b>Blank=</b> Indoor use only <b>-WP=</b> Weather-proof

**Example: ELF652D/LED**

## Grande™ Compact Series

Thermoplastic housing 6V up to 12W & 12V up to 24W capacities



### Housing

- White or black UV stabilized thermoplastic enclosure
- Clear polycarbonate lens covers

### Mounting

- Wall mount  
Optional: ceiling mount and pendant mount
- Universal J-box mounting

### Lamp type

- Choice of MR16 LED lamp wattages

### Electronics

- Pulse plus charger
- Low voltage disconnect
- Automatic brownout protection
- Battery lock-out
- Fused output circuit
- Optional Improved Diagnostics
- Optional Nexus®Pro IoT monitoring system
- Optional Nexus® monitoring system
- 120/277 60Hz

### Photometric performance

Lamp	Spacing center-to-center (feet)	
	7 Feet Mounting height	15 Feet mounting height
LD1	39'	34'
LD2	74'	57'
LD7	49'	39'
LD9	68'	54'
LD10	89'	80'

### Grande™ Thermoplastic Family



Grande™ Exit series  
PG. 36-37

Grande™  
Combo series  
PG. 38-39

Grande™  
Battery series  
PG. 90-91

ELF640 &  
ELF650  
Remote series  
PG. 136-137

### Choice of battery

- 6V or 12V Lead-calcium battery
- 6V or 12V Nickel-metal hydride

### Approval

- UL 924 Standards
- UL 94-5VA flame rated thermoplastic house
- Damp location listed 50°F to 104°F (10°C to 40°C)
- BC – California Energy Commission Title 20

### Warranty (subject to proper installation and maintenance)

- Unit has a five-year full warranty

Detailed warranty terms located on [page 197](#) or online at: [www.lightalarms.com](http://www.lightalarms.com)

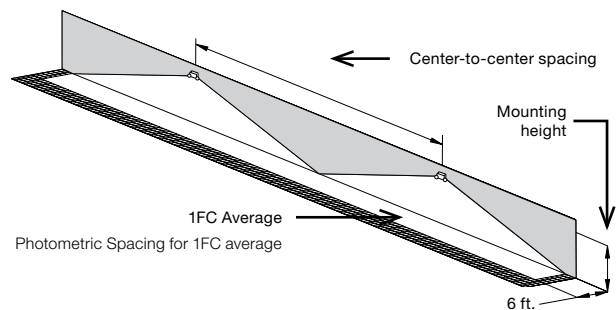

**Dimensions** (Dimensions are approximate and subject to change)

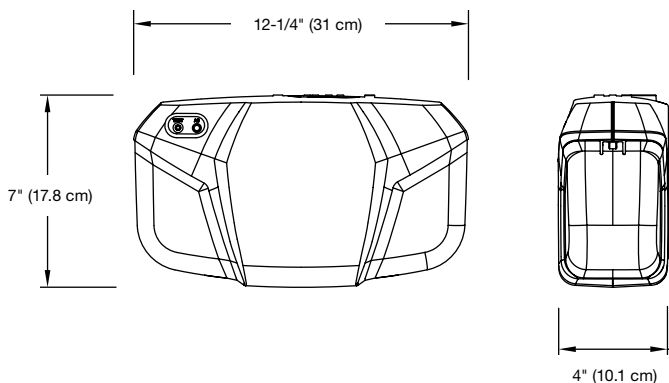

**Power consumption chart - Non-CEC models**

Series	AC Specs		Battery	Voltage	DC Specs			
	AC input	Current draw			87.5% Battery capacity (in watts) <sup>1</sup>			
					90 Mins	2 Hrs	3 Hrs	4 Hrs
MGRH1		0.21 / 0.5A		6V-12W	12W	9W	6W	4W
MGR12H1	120/277	0.12 / 0.5A	Nickel-Metal Hydride	12V-12W	12W	9W	6W	4W
MGR12H2		0.12 / 0.5A		12V-24W	24W	18W	12W	8W

<sup>1</sup> National Electrical Code Specification

**Power consumption chart - CEC models**

Series	AC Specs		Battery	Voltage	DC Specs			
	AC input	Current draw			87.5% Battery capacity (in watts) <sup>1</sup>			
					90 Mins	2 Hrs	3 Hrs	4 Hrs
MGRA1		0.12 / 0.5A		6V-10W	10W	7.5W	5W	3.3W
MGR12A1	120/277	0.20 / 0.09A	Lead-Calcium	12V-12W	12W	9W	6W	4W
MGR12A2		0.20/ 0.09A		12V-20W	20W	15W	10W	6.5W

<sup>1</sup> National Electrical Code Specification

**Ordering format**

Number of heads	Series/Capacity	Lamp/Wattage	Housing color	Diagnostic	Options	Approval
<b>Blank</b> = No heads	<b>MGRA1</b> = 6V-10W	<b>/LD1</b> = 6V-4W	<b>-M</b> = Mist white	<b>Blank</b> = Standard	<b>Blank</b> = No option	<b>-CEC</b> = CEC
<b>2</b> = Two heads	Lead-Calcium	<b>/LD2</b> = 6V-5W	<b>-B</b> = Black	<b>-ID</b> = Improved Diagnostics (audible)	<b>-CM</b> = Ceiling mount	Title 20 for California <sup>5</sup>
	<b>MGR12A1</b> = 12V-12W	<b>/LD7</b> = 12V-4W		<b>-IDNA</b> = Improved Diagnostics (non audible)	<b>-DL</b> = Damp locations <sup>2</sup>	
	Lead-Calcium	<b>/LD9</b> = 12V-5W		<b>-NEX</b> = Nexus <sup>®</sup> wired compatible <sup>1</sup>	<b>-LC</b> = Line cord (120V only)	
	<b>MGR12A2</b> = 12V-20W	<b>/LD10</b> = 12V-6W		<b>-NEXP</b> = Nexus <sup>®</sup> Pro IoT <sup>1</sup>	<b>-PM</b> = Pendant mount <sup>3</sup>	
	Lead-Calcium			<b>-NEXRF</b> = Nexus <sup>®</sup> wireless <sup>1</sup>	<b>-T3</b> = Time delay (15 minute)	
	<b>MGRH1</b> = 6V-12W Ni-MH				<b>-ZU</b> = 120/208/220-240V 50/60Hz input <sup>4</sup>	
	<b>MGR12H1</b> = 12V-12W NiMH					
	<b>MGR12H2</b> = 12V-24W NiMH					

**Example: 2MGRA1LD1M**

<sup>1</sup> Consult your sales representative  
<sup>2</sup> Not available in MGRA1  
<sup>3</sup> Pendant kit sold separately  
<sup>4</sup> Not available with -NEX and -NEXRF  
<sup>5</sup> Available with lead-calcium models only

## Grande™ Series

Thermoplastic housing 6V up to 60W & 12V up to 72W capacities



### Housing

- White or Black UV stabilized thermoplastic enclosure
- Clear polycarbonate lens covers
- Choice of MR16 LED lamp wattages

### Mounting

- Wall Mount, Ceiling Mount and pendant mount (optional)
- Universal J-Box mounting

### Electronics

- Pulse plus charger
- Low voltage disconnect
- Automatic brownout protection
- Battery lock-out
- Fused output circuit
- Optional: Improved Diagnostics
- Optional: Nexus® monitoring system
- 120/277 60Hz

### Photometric performance

Lamp	Spacing center-to-center (feet)	
	7 feet mounting height	15 feet mounting height
LD1	39'	34'
LD2	74'	57'
LD7	49'	39'
LD9	68'	54'
LD10	89'	80'

See lamps next page

### Grande™ Thermoplastic Family



Grande™ Exit series  
PG. 36-37

Grande™  
Combo series  
PG. 38-39

Grande™ Compact  
Battery series  
PG. 88-89

ELF640 &  
ELF650 Remote  
series PG.  
136-137

### Choice of Battery

- 6V or 12 V Lead-calcium battery
- 6V or 12V Nickel-cadmium battery

### Approvals

- UL 924 Listed
- UL 94, 5VA flame rated Thermoplastic housing
- Damp location listed 50°F to 104°F (10°C to 40°C)

### Warranty (subject to proper installation and maintenance)

Unit: five-year full warranty

Detailed warranty terms located on [page 197](#) or online at: [www.lightalarms.com](http://www.lightalarms.com)

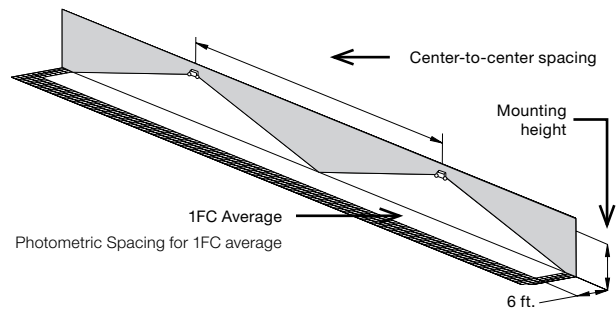

**Dimensions** (Dimensions are approximate and subject to change)

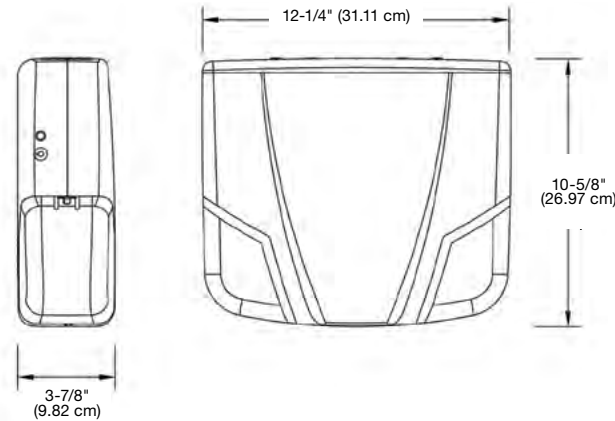

**Accessories** (Order as a separate item)

Description	Product code
Wire guard (Wall mount)	WG1-L
Wire guard (ceiling mount)	WG5-L

**Power consumption chart**

Series	Battery	Voltage	DC Specs				AC Specs	
			Battery capacity (in watts)				Units dual voltage <sup>1</sup>	Current Maximum
			90 Mins	2 Hrs	3 Hrs	4 Hrs		
GRA6	Lead-Calcium	6V	60	40	30	20	120VAC 277VAC	0.25A 0.12A
GR12A4		12V	40	30	20	15		
GR12A7		12V	72	54	36	27		
GRN2	Nickel-Cadmium	6V	20	15	10	8	120VAC 277VAC	0.2A 0.1A
GR12N4		12V	40	30	20	15		

<sup>1</sup> All units 120/277 dual voltage, information based on wiring to specific voltage type

**Ordering format**

Number of heads	Series/Capacity	Lamp type <sup>2</sup>	Housing color	Diagnostic	Options
<b>Blank</b> = No heads	<b>Lead-Calcium battery</b>	<b>MR16 LED Lamp</b>	<b>M</b> = Mist white	<b>Blank</b> = Standard	<b>Blank</b> = No Options
<b>2</b> = Two heads	<b>GRA6</b> = 6V-60W <sup>1</sup>	<b>LD1</b> = 6V-4W	<b>B</b> = Black	<b>ID</b> = Improved	<b>-CM</b> = Ceiling mount
	<b>GR12A4</b> = 12V-40W	<b>LD2</b> = 6V-5W		Diagnostics (audible) <sup>2</sup>	<b>-DL</b> = Damp location
	<b>GR12A7</b> = 12V-72W	<b>LD7</b> = 12V-4W		<b>IDNA</b> = Improved	[50°F -104°F (10°C - 40°C)]
	<b>Nickel-Cadmium battery</b>	<b>LD9</b> = 12V-5W		Diagnostics (non audible) <sup>2</sup>	<b>-PM</b> = Pendant mount
	<b>GRN2</b> = 6V-20W	<b>LD10</b> = 12V-6W		<b>NEX</b> = Nexus <sup>®</sup> wired	<b>-T3</b> = Time delay (15 minute)
	<b>GR12N4</b> = 12V-40W			compatible (consult your sales representative) <sup>2</sup>	<b>-3CP</b> = 120V Cord & plug, 3 wire, 3ft long <sup>3</sup>
				<b>NEXRF</b> = Nexus <sup>®</sup> wireless	<b>-3CP277</b> = 277V Cord & plug, 3 wire, 3ft long <sup>3</sup>
				compatible (consult your sales representative) <sup>2</sup>	<b>-240/50</b> = 240V, 50Hz

**Example: 2GRA6LD1M**

<sup>1</sup> Not available with damp location

<sup>2</sup> Minimum lamp load required: 20% of capacity

<sup>3</sup> -3CP & -3CP277 custom lengths available . Consult your sales representative

## Camray™ LED Series

Die-cast aluminum LED emergency lighting – interior or exterior



### Housing

- Indoor/outdoor suitable for wet location
- Die-cast aluminum housing
- UV-resistant (3" x 1.5") polycarbonate lens

### Mounting

- Wall mount
- 1/2" rigid conduit top entry
- Universal J-box mounting pattern

### Lamp Type

- Patent-pending light engine: four power LEDs with redundant connections
- 400-640 lumens
- Color temperature: 4000K
- Optional forward-throw light distribution, for applications of outdoor egress
- Optional high-lumen output

- Optional dual-mode operation: normal and emergency LED lighting with separate AC inputs
- Pulse plus charger
- Low voltage disconnect
- Automatic brownout protection
- Battery lock-out
- Fused output circuit
- Standard Improved Diagnostics
- 120/277 60Hz

### Approval

- UL 924 listed
- Nema-3R rated for indoor/outdoor cold-weather wet and damp locations: -4°F to 104°F (-20°C to 40°C)

**Warranty** (subject to proper installation and maintenance)

Unit: five-year full warranty

Detailed warranty terms located on [page 197](#) or online at: [www.lightalarms.com](http://www.lightalarms.com)

### Unit color

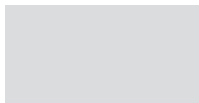

Platinum gray



Black

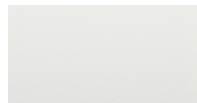

White



Dark bronze  
(painted)

**NEMA-3R**

### Power consumption chart

Model	AC Specs				DC Specs
	Normal lighting		Emergency lighting		6-12V <sup>1</sup>
	Current (maximum)	Power (maximum)	Current (maximum)	Power (maximum)	Power (maximum)
AC, 2AC, ACDC, DC	0.12/0.08A	12W	0.11/0.08A	12W	8W
All above, -H	0.18/0.11A	18W	0.18/0.11A	18W	14W (VDC only)
ACSD, SD, SD-H	0.12/0.06A	12W	0.05/0.02A	5W	
SD-CW	–	–	0.15/0.07A	16W	N/A <sup>1</sup>
ACSD-CW-P, -FT		N/A <sup>1</sup>	0.22/0.10A	24W	

<sup>1</sup> Only unswitched AC input; normal lighting with photo-switch or remote control

**Dimensions** (Dimensions are approximate and subject to change)

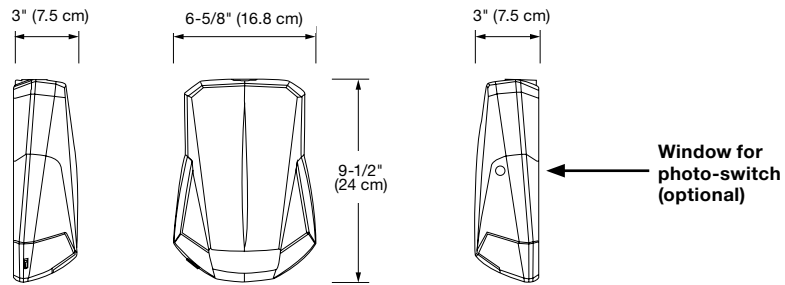

**Photometric performance**

**Table A – Spacing for NFPA101 (average = 1FC) – Average of 1 foot-candle**

Model type	Mounting height	Lumen	Color temperature	Width X length (ft)	
				Single unit	Center-to-center
Standard	9'	400	4000K	6' X 50'	6' X 50'
With option -H	11'	550		6' X 60'	6' X 60'
With option -FT	12'	460			3' X 70'
With option -FTH	15'	640		6' X 40'	–
				6' X 50'	–

**Table B – Spacing for minimum illumination = 1FC – Minimum of 1 foot-candle**

Model type	Mounting height	Lumen	Color temperature	Width X length (ft)	
				Single unit	Center-to-center
Standard	9'	400	4000K	4' X 28'	6' X 32'
With option -H	11'	550		4' X 32'	6' X 40'
With option -FH	12'	460		4' X 22'	–
With option -FTH	15'	640		4' X 27'	–

**Indoor reflectance: 80/50/20 and 10-ft wide corridor. Outdoor reflectance: 0/30/10**

Note: The illumination level meets ALL the requirements of the Life Safety Code (NFPA 101):

- 1) Average of 1 foot-candle or more
- 2) Minimum at any point of 0.1 foot-candle or more
- 3) Maximum-to-minimum illumination uniformity ratio of 40:1 or less

**Photometry performance**

Whether installed indoors or outdoors, with spacing measurements for a single unit or between two units center-to-center, the Camray® Series LED delivers a stable and consistent illumination making it easy to specify in a wide range of applications. The outstanding spacing of illumination ranges from 50 to 70 feet for standard units (wide beam) and from 40 to 50 feet with the forward-throw beam option.

**Photometry performance – Wide beam**

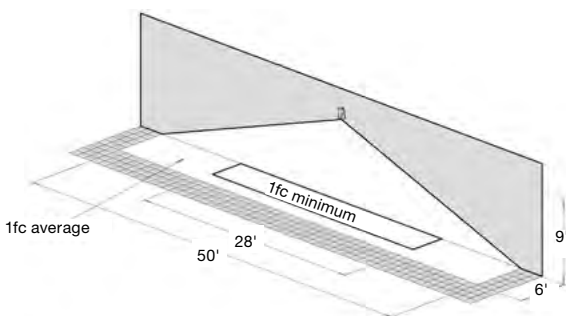

**Photometry performance – Forward throw**

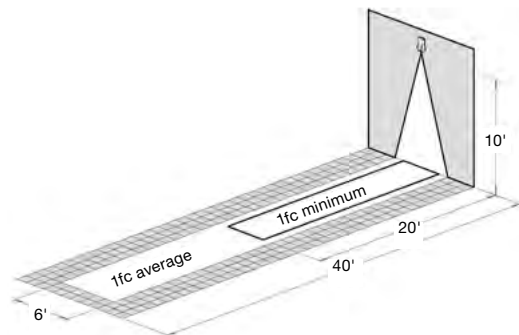

**Ordering format – Battery unit**

Series	Model	Color	Options
<b>CAM=</b> Camray LED battery unit	<b>Nickel-Metal Hydride Battery Units (standard with Self-Diagnostics)</b>  <b>SD=</b> Self-Powered & Self-Diagnostic (-4°F + 122°F)(-20°C + 50°C) <b>ACSD=</b> Dual-Mode AC/Self-Powered & Diagnostics (-4°F + 104°F)(-20°C + 40°C)	<b>B=</b> Black <b>DB=</b> Dark bronze <b>OW=</b> Off white <b>PG=</b> Platinum gray	<b>-CW=</b> Cold weather (-40°F - 86°F)(-40°C - 30°C); not available with option -H <b>-FT=</b> Forward throw lighting <b>-H=</b> High lumen output (32... 86°F / 0... 30°C; model SD only)
			<b>-P=</b> Photo-switch, (model models ACSD only) <b>-T3=</b> Time delay: 15 minutes (models ACSD, SD only) <b>-RC=</b> Remote control - infrared <sup>1</sup>

**Example: CAMSDOW-RC**

<sup>1</sup> For ACSD Model only, with -RC option, order the remote control keypad (TB-RC1-L) separately

## MG/MN-SP Series

Steel housing 12V up to 40W capacities Lead-Calcium or Nickel-Cadmium battery high performance LED heads



### Housing

- Steel housing
- Standard gray finish, optional black finish

### Lamp heads

- 6W (L6 lamp suffix), 10W (L10 lamp suffix) and 15W (L15 lamp suffix) high efficacy LED emergency heads outperform traditional 50W MR16-IR Halogen
- Black heads available in 15W (L15 lamp suffix) only
- Innovative head design: four-LED and dual-driver provide illumination even in case of unexpected component failure
- Die-cast aluminum, LED heads

### Mounting

- Wall or ceiling mount
- Universal J-box mounting

### Electronics

- Pulse plus charger
- Low voltage disconnect
- Automatic brownout protection

- Battery lock-out
- Fused output circuit
- Optional: Improved Diagnostics
- Optional: Nexus® monitoring system
- 120/277 60Hz

### Choice of Battery

- 12V Lead-Calcium battery
- 12V Nickel-Cadmium battery

### Approvals

- UL 924 Listed
- BC – California Energy Commission Title 20

**Warranty** (subject to proper installation and maintenance)

Unit: five-year limited warranty

Detailed warranty terms located on [page 197](#) or online at: [www.lightalarms.com](http://www.lightalarms.com)



### Power consumption chart - Non-CEC models

Series	Battery	Voltage	DC Specs				AC Specs	
			Battery capacity (in watts)				Units dual voltage <sup>1</sup>	Current Maximum
			90 Mins	2 Hrs	3 Hrs	4 Hrs		
M12N1	Nickel-Cadmium	12V	30	21	15	12	120VAC / 277VAC	0.3A / 0.15A
M12N2		12V	40	36	25	18		

<sup>1</sup> All units 120/277 dual voltage, information based on wiring to specific voltage type

### Power consumption chart - CEC models

Series	Battery	Voltage	DC Specs				AC Specs	
			Battery capacity (in watts)				Units dual voltage <sup>1</sup>	Current Maximum
			90 Mins	2 Hrs	3 Hrs	4 Hrs		
M12G1	Lead-Calcium	12V	36	25	20	14	120VAC / 277VAC	0.3A / 0.15A

<sup>1</sup> All units 120/277 dual voltage, information based on wiring to specific voltage type



**Dimensions** (Dimensions are approximate and subject to change)

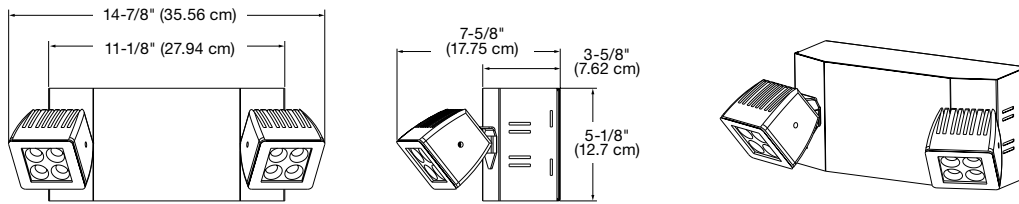

**Photometry performance**

For NEMA 1 type application, the MG/MN-SP Series LED emergency lights deliver a stable and consistent illumination on the path of egress for a wide range of mounting heights. Depending on the required illumination levels need for the application, choose between three level of lumen output using a 6W, 10W or 15W head.

LED Head	Power	Total lumens	Outperform spacing of MR16 halogen lamp types
L6	6W	565	37W PAR36, MR16 Halogen
L10	10W	1000	50W PAR36, MR16 Halogen
L15	15W	1300	50W MR16-IR Halogen

**Spacing center-to-center (feet)**

Mounting height	Lamp L6/6W, 565Lm	Lamp L10/10W, 1000Lm	Lamp L15/15W, 1300Lm
10 ft	80'	110'	140'
15 ft	70'	105'	135'
20 ft	60'	100'	130'
25 ft	50'	95'	120'

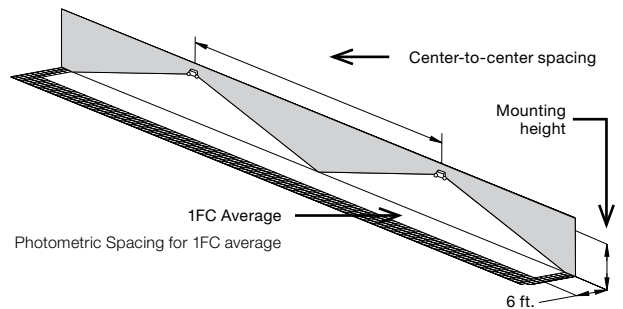

Wall mounted equipment, reflectances: 10/10/10; 6-ft wide illumination path. Illumination as per NFPA101; Average: 1fc; Min: 0.1fc; Max/min< 40:1

**Accessories** (Order as a separate item)

Description	Product code
Mounting platform	MP-PQA
Wire Guard	WG10-L

**Ordering format**

Number of heads	Series/Capacity	Head style	Housing color	Mounting head	Options	Approval
2= Two heads	<b>Lead-Calcium battery</b> /L6= 12V-6W <b>M12G1SP</b> = 12V-36W (565 Lumens) <b>Nickel-Cadmium battery</b> /L10= 12V-10W (1000 Lumens) <b>M12N1SP</b> = 12V-30W /L15= 12V-15W (1300 Lumens) <b>M12N2SP</b> = 12V-40W		<b>G</b> = Gray <b>B</b> = Black <sup>1</sup>	<b>-FM</b> = Front mount heads	<b>Blank</b> = No options <b>-ID</b> = Improved Diagnostics (audible) <sup>2</sup> <b>-IDNA</b> = Improved Diagnostics (non audible) <sup>2</sup> <b>-NEX</b> = Nexus® Wired compatible <sup>3</sup> <b>-NEXRF</b> = Nexus® Wireless compatible <sup>3</sup> <b>-T3</b> = Time delay (15 minute) <sup>4</sup> <b>-3CP</b> = 120V Cord & Plug, 3 wire, 3ft long <sup>5</sup> <b>-3CP277</b> = 277V Cord & plug, 3 wire, 3ft long <sup>5</sup>	<b>-CEC</b> = CEC Title 20 for California <sup>6</sup>

**Example: 2M12G1SP/L15G-FM-ID**

<sup>1</sup> Available with 15 watt heads only  
<sup>2</sup> -ID & -IDNA include a time delay feature that can be enabled/ disabled in the field or set by the factory by including -ID-TD\* or -IDNA-TD\*  
<sup>3</sup> -NEX & -NEXRF is CSA-US approved only. Consult your sales representative  
<sup>4</sup> Time delay only available with ID, IDNA, NEX or NEXRF models  
<sup>5</sup> -3CP & -3CP277 custom lengths available . Consult your sales representative  
<sup>6</sup> Available with lead-calcium models only

## MG & MN Series

Steel housing 6V and 12V up to 36W capacities

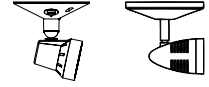

**Available Head Style Choices:** ELF3 DR130  
**Head Style Suffix:** /ELF3 /DR130

BATTERY UNITS

### Housing

- Steel housing
- Standard mist white finish, optional black finish
- Choice of MR16 LED lamp voltages and wattages
- Heads available in thermoplastic or decorative die-cast aluminum

### Mounting

- Ceiling or wall mount
- Universal J-box mounting

### Electronics

- Pulse plus charger
- Low voltage disconnect
- Automatic brownout protection
- Battery lock-out
- Fused output circuit
- Optional Improved Diagnostics
- Optional Nexus® monitoring system
- 120/277 60Hz

### Choice of Battery

- 6V or 12V Lead-Calcium battery
- 6V or 12V Nickel-Cadmium battery

### Approvals

- UL 924 Standard
- BC – California Energy Commission Title 20

### Warranty (subject to proper installation and maintenance)

Unit: three-year limited warranty

Detailed warranty terms located on **page 197** or online at: [www.lightalarms.com](http://www.lightalarms.com)



### Photometric performance

Lamp	Spacing center-to-center (feet)	
	7 feet mounting height	15 feet mounting height
LD1	43'	36'
LD2	81'	64'
LD7	55'	43'
LD9	71'	56'
LD10	100'	85'

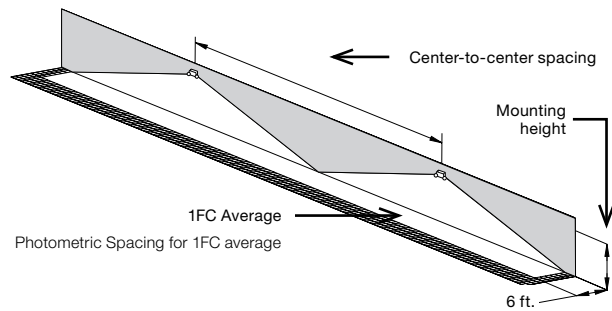

### Housing color



Black

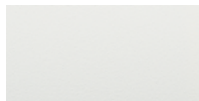

Mist White

**Dimensions** (Dimensions are approximate and subject to change)

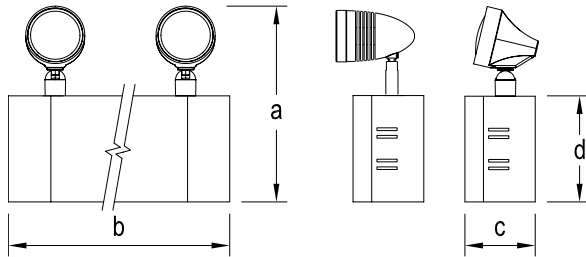

**Cabinet dimensions**

Units	Cabinet	a	b	c	d
50W and under	S	11-3/8"	11"	3-1/2"	5-1/4"
54W and higher	L	12-3/8" 10-3/4"	12-1/2"	4"	6-1/4"

**Power consumption chart - Non-CEC models**

Series	Battery	Voltage	DC Specs				AC Specs	
			Battery capacity (in watts)				Units dual voltage <sup>1</sup>	Current Maximum
			90 Mins	2 Hrs	3 Hrs	4 Hrs		
MG18	Lead-Calcium	6V	18	12	0	120VAC 277VAC	0.3A 0.15A	
MG1		6V	27	18	14			0
M12G1		12V	36	25	20			14
MN1	Nickel-Cadmium	6V	25	18	12	120VAC 277VAC	0.3A 0.15A	
M12N1		12V	36	21	15			12
M12N2		12V	50	36	25			18

<sup>1</sup> All units 120/277 dual voltage, information based on wiring to specific voltage type

**Power consumption chart - CEC models**

Series	Battery	Voltage	DC Specs				AC Specs		
			Battery capacity (in watts)				Units dual voltage <sup>1</sup>	Current Maximum	Stand-by power
			90 Mins	2 Hrs	3 Hrs	4 Hrs			
MG18	Lead-Calcium	6V	18	12	9	120/277VAC	0.09/0.04A	0.62W	
MG1		6V	27	18	14				0
M12G1		12V	36	24	18				13

<sup>1</sup> All units 120/277 dual voltage, information based on wiring to specific voltage type

**Accessories** (Order as a separate item)

Description	Product code
Mounting platform	MP-PQA
Wire guard (S cabinet)	WG1-L
Wire guard (L cabinet)	WG2-L
Wire guard (Front mounted heads)	WG10-L

**Ordering format**

Number of heads	Series/Capacity	Head style	Lamp type	Housing color	Options	Approval
0= No Heads	<b>Lead-Calcium battery</b>	<b>/ELF3=</b> ELF3 (MR16, Plastic)	<b>LD1=</b> 6V-4W MR16 LED	<b>-M=</b> Mist white <b>-B=</b> Black	<b>Blank=</b> No Options <b>-ID=</b> Improved Diagnostics (audible) <sup>1</sup> <b>-IDNA=</b> Improved Diagnostics (non audible) <sup>1</sup> <b>-FM=</b> Front mounted heads <b>-NEX=</b> Nexus® Wired (contact your sales representative) <b>-NEXRF=</b> Nexus® Wireless (contact your sales representative) <b>-T3=</b> Time delay (15 minute) <sup>2</sup> <b>-FM=</b> Front mounted heads <b>-3CP=</b> 120V Cord & plug, 3 wire, 3ft long <sup>3</sup> <b>-3CP277=</b> 120V cord & plug 3 wire, 3 ft. long <sup>3</sup>	<b>-CEC=</b> CEC Title 20 for California <sup>4</sup>
2= Two Heads	MG18= 6V-18W MG1= 6V-27W M12G1= 12V-36W	<b>/DR130=</b> DR130 (MR16, Metal)	<b>LD2=</b> 6V-5W MR16 LED <b>LD7=</b> 12V-4W MR16 LED <b>LD9=</b> 12V-5W MR16 LED <b>LD10=</b> 12V-6W MR16 LED			
3= Three Heads	<b>Nickel-Cadmium battery</b> M12N1= 12V-36W M12N2= 12V-50W					

**Example: 2MG18/ELF3-LD1-M-ID**

<sup>1</sup> -ID & -IDNA include a time delay feature that can be enabled/disabled in the field or set by the factory by including -ID-TD\* or -IDNA-TD\*

<sup>2</sup> Time delay only available with ID, IDNA, NEX or NEXRF models

<sup>3</sup> -3CP custom lengths available. Consult your sales representative

<sup>4</sup> Must chose ID, IDNA or NEXRF

## PG, PQ, P12G & P12Q Series

Steel housing 6V-54W & 12V up to 200W capacities Lead-Calcium battery



BATTERY UNITS

### Housing

- Steel housing
- Standard mist white finish, optional black finish
- Choice of MR16 LED lamp voltages and wattages
- Heads available in thermoplastic or decorative die-cast aluminum

### Mounting

- Wall mount
- Universal J-box mounting

### Electronics

- Pulse plus charger
- Low voltage disconnect
- Automatic brownout protection
- Battery lock-out
- Fused output circuit
- Optional: Improved Diagnostics
- Optional: Nexus® monitoring system
- 120/277 60Hz

### Photometric performance

Lamp	Spacing center-to-center (feet)	
	7 feet mounting height	15 feet mounting height
LD1	43'	36'
LD2	81'	64'
LD7	55'	43'
LD9	71'	56'
LD10	100'	85'

### Housing color



Black

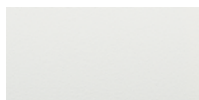

Mist White

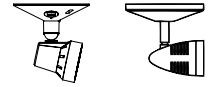

**Available Head Style Choices:** ELF3 DR130  
**Head Style Suffix:** /ELF3 /DR130

### Choice of Battery

- 6V or 12V Lead-Calcium battery

### Approvals

- UL 924 Standard
- New York City Approved

### Warranty (subject to proper installation and maintenance)

Unit: three-year limited warranty

Detailed warranty terms located on [page 197](#) or online at: [www.lightalarms.com](http://www.lightalarms.com)

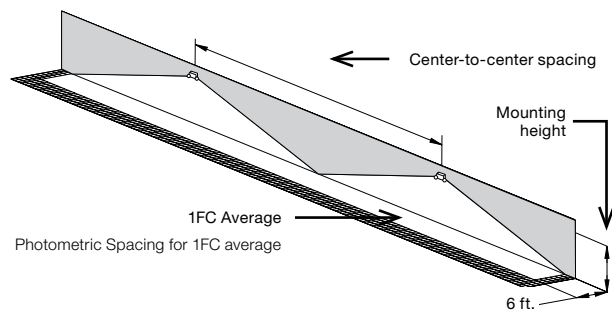

**Dimensions** (Dimensions are approximate and subject to change)

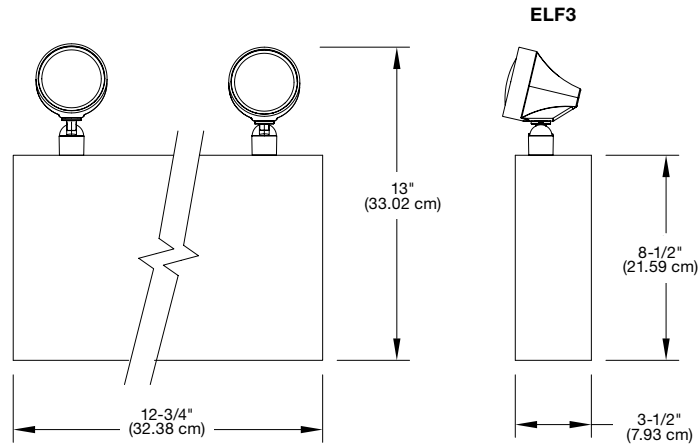

**Power consumption chart**

Series	Battery	Voltage	DC Specs				AC Specs	
			Battery capacity (in watts)				Units dual voltage <sup>1</sup>	Current Maximum
			90 Mins	2 Hrs	3 Hrs	4 Hrs		
PG1	Lead-Calcium	6V	18	15	0	0	120VAC 277VAC	0.25A 0.15A
PG2		6V	54	36	27	18		
P12G1		12V	54	36	27	18		
P12Q1	Lead-Calcium	12V	100	75	50	36	120VAC 277VAC	0.3A 0.15A
P12Q2		12V	200	150	100	72		

<sup>1</sup> All units 120/277 dual voltage, information based on wiring to specific voltage type

**Accessories** (Order as a separate item)

Description	Product code
Wire guard	WG2-L
Mounting platform	MP-PQA

**Ordering format**

Number of heads	Series/Capacity	Head style	Lamp type	Housing color	Options
0= No heads	<b>PG1</b> = 6V-18W	<b>/ELF3</b> = ELF3	<b>LD1</b> = 6V-4W MR16 LED	<b>-M</b> = Mist White	<b>Blank</b> = No Options
2= Two heads	<b>PG2</b> = 6V-54W	(MR16, Plastic)	<b>LD2</b> = 6V-5W MR16 LED	<b>-B</b> = Black	<b>-ID</b> = Improved Diagnostics (audible) <sup>1,2</sup>
3= Three Heads	<b>P12G1</b> = 12V-54W	<b>/DR130</b> = DR130	<b>LD7</b> = 12V-4W MR16 LED		<b>-IDNA</b> = Improved Diagnostics (non audible) <sup>1,2</sup>
	<b>P12Q1</b> = 12V-100W	(MR16, Metal)	<b>LD9</b> = 12V-5W MR16 LED		<b>-NEX</b> = Nexus® Wired (contact your sales representative) <sup>2</sup>
	<b>P12Q2</b> = 12V-200W		<b>LD10</b> = 12V-6W MR16 LED		<b>-NEXRF</b> = Nexus® Wireless (contact your sales representative) <sup>2</sup>
					<b>-T3</b> = Time delay (15 minute) <sup>3</sup>
					<b>-DS</b> = Lamp disconnect switch
					<b>-VS</b> = Vandal-Resistant Screws
					<b>-3CP</b> = 120V Cord & plug, 3 wire, 3ft long <sup>4</sup>

**Example: 2PG1/DR130LD1**

<sup>1</sup> -ID & -IDNA include a time delay feature that can be enabled/disabled in the field or set by the factory by including -ID-TD\* or -IDNA-TD\*

<sup>2</sup> Minimum lamp load required: 20% of unit capacity

<sup>3</sup> Time delay only available with ID, IDNA, NEX or NEXRF models

<sup>4</sup> -3CP custom length available. Consult your sales representative

## S12E & S24E Series

Steel housing 12V up to 400W & 24V-400W capacities Lead-Calcium battery

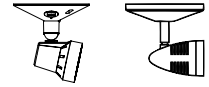
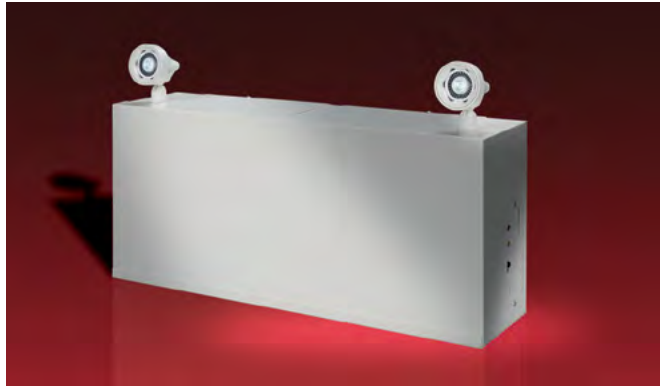

**Available Head Style Choices:** ELF3 DR130  
**Head Style Suffix:** /ELF3 /DR130

BATTERY UNITS

### Housing

- Steel housing
- Standard mist white finish, optional black finish
- Choice of 12 or 24 volt MR16 LED lamp wattages
- Heads available in Thermoplastic or decorative die-cast aluminum

### Mounting

- Wall Mount
- Universal J-Box mounting

### Electronics

- Pulse plus charger
- Low voltage disconnect
- Automatic brownout protection
- Battery lock-out
- Fused output circuit
- Optional: Improved Diagnostics
- Optional: Nexus® monitoring system
- 120/277 60Hz

### Choice of Sealed Maintenance-Free Battery

6V or 12V Nickel-Cadmium battery

### Approvals

- UL 924 Standard
- New York City Approved

### Warranty (subject to proper installation and maintenance)

Unit: three-year full warranty

Detailed warranty terms located on **page 197** or online at: [www.lightalarms.com](http://www.lightalarms.com)



### Photometric performance

Lamp	Spacing center-to-center (feet)	
	7 feet mounting height	15 feet mounting height
LD7	55'	43'
LD9	71'	56'
LD10	100'	85'
LD13	56'	44'
LD14	106'	87'

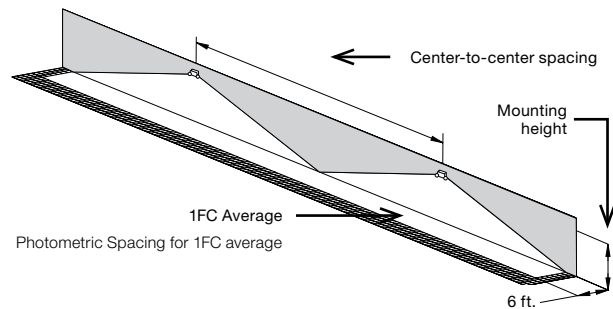

### Housing color

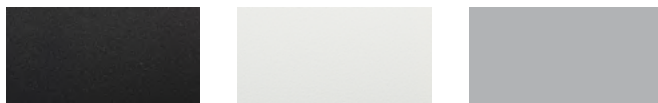

Black

Mist White

Gray

**Dimensions** (Dimensions are approximate and subject to change)

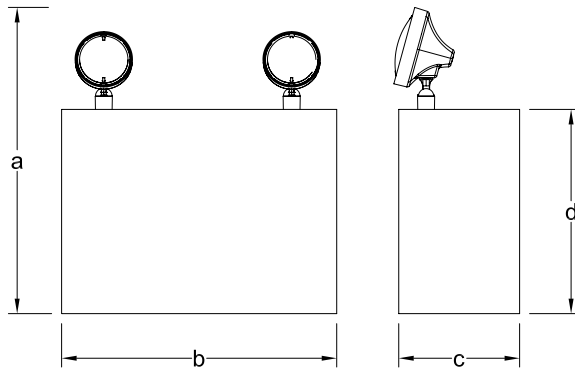

**Cabinet dimensions**

Cabinet	Dimensions			
	a	b	c	d
C	18-3/8" (46.67cm)	16-1/2" (41.91cm)	7-1/4" (18.41cm)	12-1/4" (32.38cm)
D	18-3/8" (46.67cm)	27" (68.58cm)	7-1/4" (18.41cm)	12-1/4" (32.38cm)

200W unit use C Cabinet dimensions  
300W and 400W unit use D Cabinet dimensions

**Power consumption chart**

Series	Battery	Voltage	DC Specs				Units dual voltage <sup>1</sup>	AC Specs Current Maximum
			Battery capacity (in watts)					
			90 Mins	2 Hrs	3 Hrs	4 Hrs		
S1245		12V	300	225	165	127		
S12E6	Lead-Calcium	12V	400	300	214	170		
S24E4		24V	400	300	120	60		

<sup>1</sup> All units 120/277 dual voltage, information based on wiring to specific voltage type

**Accessories** (Order as a separate item)

Description	Product code
Wire guard (S12E5/S12E6/S24E4)	WG4-L
Mounting platform (S12E4)	MP-A
Mounting platform (S12E5/S12E6/S24E4)	MD-12
Mounting bracket (S12E4/S24E4)	MB-A

**Ordering format**

Number of heads	Series/Capacity	Head style	Lamp type	Housing color	Options
0= No heads	<b>S12E5</b> = 12V-300W	<b>/ELF3</b> = ELF3	<b>LD7</b> = 12V-4W MR16 LED	<b>-G</b> = Gray	<b>Blank</b> = No Options
2= Two heads	<b>S12E6</b> = 12V-400W	(MR16, Plastic)	<b>LD9</b> = 12V-5W MR16 LED	<b>-M</b> = Mist white	<b>-ID</b> = Improved Diagnostics (audible) <sup>1,2</sup>
3= Three Heads	<b>S24E4</b> = 24V-400W	<b>/DR130</b> = DR130 (MR16, Metal)	<b>LD10</b> = 12V-6W MR16 LED <b>LD13</b> = 24V-4W MR16 LED <b>LD14</b> = 24V-6W MR16 LED	<b>-B</b> = Black	<b>-IDNA</b> = Improved Diagnostics (non audible) <sup>1,2</sup> <b>-NEX</b> = Nexus <sup>®</sup> Wired (contact your sales representative) <sup>2</sup> <b>-NEXRF</b> = Nexus <sup>®</sup> Wireless (contact your sales representative) <sup>2</sup> <b>-T3</b> = Time delay (15 minute) <sup>3</sup> <b>-DS</b> = Lamp disconnect switch <b>-VS</b> = Vandal-resistant screws <b>-3CP</b> = 120V Cord & plug, 3 wire, 3ft long <sup>4</sup>

**Example: 2S12E4/ELF3LD7-G**

<sup>1</sup> -ID & -IDNA include a time delay feature that can be enabled/disabled in the field or set by the factory by including -ID-TD\* or -IDNA-TD\*

<sup>2</sup> Minimum lamp load required: 20% of unit capacity

<sup>3</sup> Time delay only available with ID, IDNA, NEX or NEXRF models

<sup>4</sup> -3CP custom length available. Consult your sales representative

## Severe™ Series

NEMA-4X, NSF, Vandal-Resistant housing 6V-18W & 12V up to 60W capacities  
Lead-Calcium, Nickel-Cadmium or Nickel-Metal Hydride battery



BATTERY UNITS

### Housing

- Full gasketed NEMA-4X die-cast aluminium housing
- Vandal-resistant UV stabilized polycarbonate cover
- Comes with both Phillips head and tamper-proof screws

### Mounting

- Universal J-box mounting
- Strut or I-beam installation bracket sold separately (order catalog number: PMK-E)

### Lamp type

- Choice of MR16 LED lamp voltages and wattages

### Electronics

- Pulse plus charger
- Low voltage disconnect
- Automatic brownout protection
- Battery lock-out
- Fused output circuit
- Magnetic test switch
- Standard Improved Diagnostics (non-audible)
- Standard 15 minutes time delay
- Optional Nexus®Pro IoT monitoring system

### Photometric performance

Lamp	Spacing center-to-center (feet)	
	7 feet mounting height	15 feet mounting height
LD1	39'	34'
LD2	74'	57'
LD7	49'	39'
LD9	68'	54'
LD10	89'	80'

### Housing color

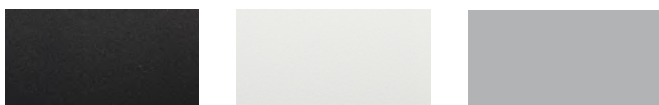

Black

White

Gray

### The Severe™ XV Series Family



Severe™ XV exit series  
PG. 48-49



Severe™ XV combo series  
PG. 50-51



Severe™ ELF650 remote series  
PG. 137

- Optional Nexus® wire and wireless monitoring system
- 120/277 60Hz

### Choice of Battery

- 6V or 12V Lead-Calcium battery
- 12V Nickel-Cadmium battery
- 12V Nickel-Metal Hydride battery

### Approvals

- UL 924 Listed
- UL listed for wet and damp location 50°F to 104°F (10°C to 40°C)
- UL listed for cold weather option -40°F to 104°F (-40°C to 40°C)
- NSF certified for use in food processing plants
- NEMA-4X Rated
- BC – California Energy Commission Title 20

### Warranty (subject to proper installation and maintenance)

Unit: five-year full warranty

Detailed warranty terms located on **page 197** or online at: [www.lightalarms.com](http://www.lightalarms.com)

nexus NEMA-4X



Nexus®Pro

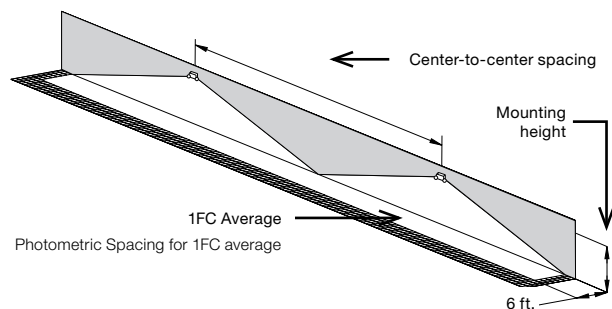



**Dimensions** (Dimensions are approximate and subject to change)

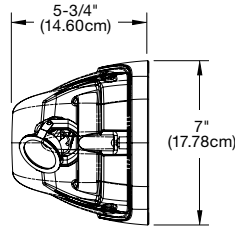
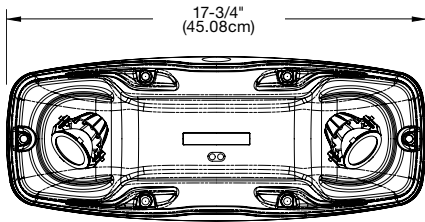

**Universal mounting brackets**

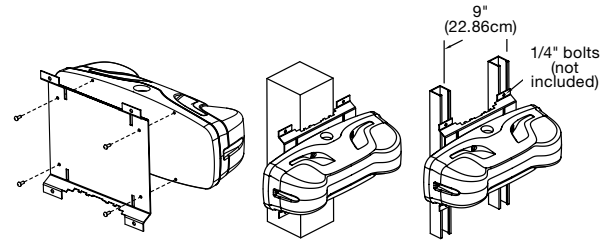

**Power consumption & unit rating chart - Non-CEC models**

Series	Battery	Voltage	DC Specs				AC Specs		
			Battery capacity (in watts)				Units dual voltage <sup>1</sup>	Current Maximum	Power Maximum
			90 Mins	2 Hrs	3 Hrs	4 Hrs			
V12N1	Nickel-Cadmium	12V	24	16	12	-	120VAC 277VAC	0.2A 0.11A	20W 20W
V12N2		12V	40	30	20	15			
V12H1	Nickel Metal Hydride	12V	60	40	30	20			

<sup>1</sup> All units 120/277 dual voltage, information based on wiring to specific voltage type  
<sup>2</sup> Dependent on lower ambient temperatures

**Power consumption & unit rating chart - CEC models**

Series	Battery	Voltage	DC Specs				AC Specs		
			Battery capacity (in watts)				Units dual voltage <sup>1</sup>	Current Maximum	Power Maximum
			90 Mins	2 Hrs	3 Hrs	4 Hrs			
VG1	Lead-Calcium	6V	18	12	-	-	120VAC 277VAC	0.2A 0.11A	20W 20W
V12G1		12V	24	16	12	-			
V12G2		12V	36	24	20	14			
V12G3		12V	54	36	27	20			
V12G1-CW4	With cold-weather option	12V	24	Note 2	-	-	120/277VAC	0.4A/0.3A	60W
V12G2-CW4		12V	36		-	-			

<sup>1</sup> All units 120/277 dual voltage, information based on wiring to specific voltage type  
<sup>2</sup> Dependent on lower ambient temperatures

**Accessories** (Order as a separate item)

Description	Product code
Bit for Tamper-proof screws	690.0454-L
Universal mounting bracket	PMK-L

**Ordering format**

# of heads	Series/Capacity	Lamp type	Housing color	Diagnostics	Options	Approval
2= Two heads	<b>Lead-Calcium battery</b> <b>VG1= 6V-18W</b> <b>V12G1= 12V-24W</b> <b>V12G2= 12V-36W</b> <b>V12G3= 12V-54W</b> <b>Nickel-Cadmium battery</b> <b>V12N1= 12V-24W</b> <b>V12N2= 12V-40W</b> <b>Nickel-Metal Hydride battery</b> <b>V12H1= 12V-60W</b>	<b>MR16 LED Lamp</b> <b>LD1= 6V-4W</b> <b>LD2= 6V-5W</b> <b>LD7= 12V-4W</b> <b>LD9= 12V-5W</b> <b>LD10= 12V-6W</b>	<b>-B= Black</b> <b>-G= Gray</b> <b>-M= White</b>	<b>Standard Diagnostic</b> <b>-D= Improved Diagnostics, non-audible</b> <b>Optional Diagnostic</b> <b>-DA= Improved Diagnostics, audible</b> <b>NEX= Nexus® Wired<sup>1</sup></b> <b>NEXP= Nexus® Pro IoT<sup>1</sup></b> <b>NEXRF= Nexus® Wireless<sup>1</sup></b>	<b>Blank= No Options</b> <b>-T3= Time delay (15 minute)</b> <b>-CW4= Cold Weather -40°F to 104°F (-40°C to 40°C)<sup>2</sup></b> <b>-SMC= Surface ceiling mount</b>	<b>-CEC= CEC Title 20 for California<sup>3</sup></b>

**Example: 2V12G2/LD10-B-D-CW4**

<sup>1</sup> Consult your sales representative  
<sup>2</sup> -CW4 option only available with V12N1 (none Nexus®), V12G1 & V12G2 models  
<sup>3</sup> Available with lead-calcium models only

## SP Series

NEMA-4X, Severe-performance industrial battery unit for indoor or outdoor applications



### Housing

- Compact gray fiberglass housing with captive screws
- NEMA-4X rated
- All external fasteners and hardware are constructed of stainless steel
- Die-cast aluminum LED heads

### Mounting

- Simple and easy to install on walls, poles, columns, struts also on vertical
- Pole or column installation bracket sold separately (order catalog number: PMK1-L)
- ½ NPT conduit entry on top or side

### Performance

- High temperature Lead-Calcium battery operates 32°F to 122°F (0°C to 50°C) and Nickel-Cadmium battery operates 50°F to 104°F (10°C to 40°C) ; optional cold-weather -40°F to 122°F (-40°C to 50°C)
- 6W, 10W and 15W high efficacy LED emergency heads
- 15W head outperforms traditional 50W MR16 Halogen
- Innovative head design: four-LED and dual- driver provide illumination even in case of unexpected component failure

### Electronics

- Infra-red remote control tester included with all models: allows testing the equipment without the need to climb a ladder. Distance range up to 30 ft. Universal, one remote control tester can test all the units on the job
- Pulse plus charger
- Low voltage disconnect
- Automatic brownout protection
- Battery lock-out
- Fused output circuit
- Standard Improved Diagnostics (non-audible)
- Optional: Nexus® monitoring system
- 120/277 60Hz

### Approvals

- UL 924 Listed
- BC – California Energy Commission Title 20

**Warranty** (subject to proper installation and maintenance)

Unit: five-year limited warranty

Detailed warranty terms located on [page 197](#) or online at: [www.lightalarms.com](http://www.lightalarms.com)

nexus **NEMA-4X**

**id.**  
improved  
diagnostics



### Photometry performance

Capable of being installed indoors or outdoors, the SP Series LED emergency lights deliver a stable and consistent illumination on the path of egress for a wide range of mounting heights. Depending on the required illumination levels need for the application, choose between three level of lumen output using a 6W, 10W or 15W head.

LED Head	Power	Total lumens	Outperform spacing of MR16 halogen lamp types
L6	6W	565	37W PAR36, MR16 Halogen (700 Lumens)
L10	10W	1000	50W PAR36, MR16 Halogen (950 Lumens)
L15	15W	1300	50W MR16-IR Halogen (1550 Lumens)

### Spacing center-to-center (feet)

Mounting height	Lamp L6/6W, 565Lm	Lamp L10/10W, 1000Lm	Lamp L15/15W, 1300Lm
10 ft	80'	110'	140'
15 ft	70'	105'	135'
20 ft	60'	100'	130'
25 ft	50'	95'	120'

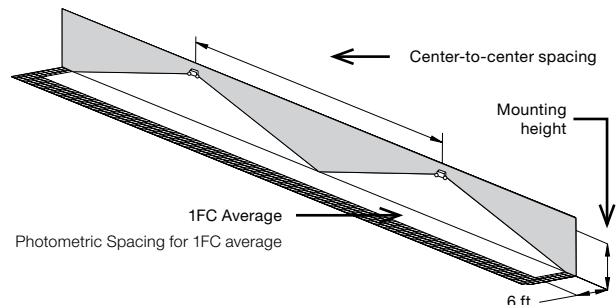

Industrial environment: Wall mounted equipment, reflectances: 10/10/10; 6-ft wide illumination path. Illumination as per NFPA101; Average: 1fc; Min: 0.1fc; Max/min < 40:1

**Dimensions** (Dimensions are approximate and subject to change)

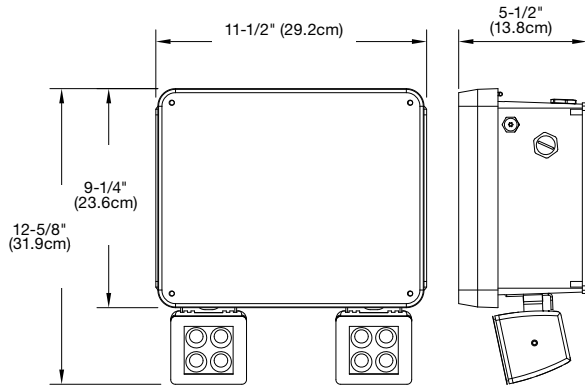

**PMK1-L Universal Mounting Bracket Installation**

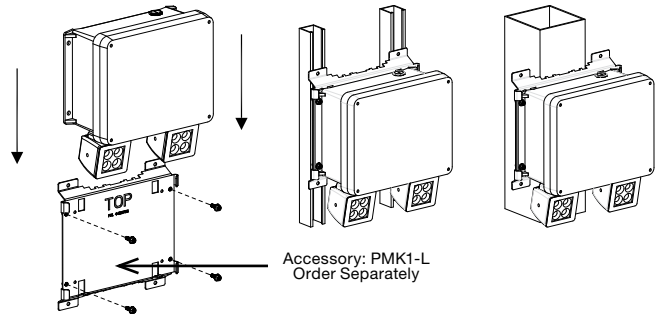

**Unit rating chart - Non-CEC models**

Series	DC Specs (87.5% battery capacity in watts)			
	90 minutes	2 Hrs	3 Hrs	4 Hrs
SP12N4	40	36	24	18
SP24N9	90	71	48	36

Note: the cold-weather option is only rated for 90 minutes.

**Unit rating chart - CEC models**

Series	DC Specs (87.5% battery capacity in watts)			
	1 1/2 Hrs	2 Hrs	3 Hrs	4 Hrs
SP12G3	30	20	15	10
SP12G6	60	40	30	20

Note: the cold-weather option is only rated for 90 minutes

**Remote test control (included with unit)**



Standard infrared remote test control tester included with all models: allow to test the equipment without need to climb a ladder. Functional up to 30 ft distance. Universal, one Remote Test Control can test all units on the job.

**Power consumption chart**

Temperature	Specification
Standard temperature range	120/277VAC, 60Hz, 0.30/0.15A
Cold-weather option	120/277VAC, 60Hz, 0.70/0.35A

**Ordering format**

Series	Battery and capacity	Number of heads	LED heads <sup>1</sup>	Diagnostics	Option	Approval
SP12	<b>High Temperature Lead-Calcium</b>	0= No head	<b>L6=</b> 12-24V, 6W (565 Lumens)	<b>ID=</b> Improved Diagnostics, audible	<b>CW4=</b> Cold-weather -40°F (-40°C) <sup>2</sup>	<b>-CEC=</b> CEC Title 20 for California <sup>3</sup>
SP12	<b>G3=</b> 12V-30W, High temperature Lead-Calcium battery, Temperature= 32°F to 122°F (0...50°C)	1= One head	<b>L10=</b> 12-24V, 10W (1000 Lumens)	<b>IDNA=</b> Improved Diagnostics, non-audible	<b>T3=</b> Time delay 15 minutes	
SP12	<b>G6=</b> 12V-60W, High temperature Lead-Calcium battery, Temperature= 32°F to 122°F (0...50°C)	2= Two heads	<b>L15=</b> 12-24V, 15W (1300 Lumens)	<b>NEX=</b> Nexus® Wired (contact your sales representative)	<b>RFI=</b> Radio frequency interference filter	
SP12	<b>Nickel-Cadmium</b>			<b>NEXRF=</b> Nexus® Wireless (contact your sales representative)		
SP12	<b>N4=</b> 12V-40W, Nickel-Cadmium battery, Temperature= 50°F to 104°F (10...40°C)			<b>NID=</b> No Improved Diagnostics		
SP24	<b>N9=</b> 24V-90W, Nickel-Cadmium battery, Temperature= 50°F to 104°F (10...40°C)					

**Example: SP12N42L6IDNARFI**

<sup>1</sup> For total Unit battery draw multiple head number by wattage

<sup>2</sup> Only available on 12V Models

<sup>3</sup> Available with lead-calcium models only

## SPRL Series Remote Fixture

NEMA-4X, Severe-performance remote for indoor or outdoor applications



### Housing

- Lightweight polycarbonate gray housing with captive screws
- NEMA-4X protection grade
- All external fasteners and hardware are constructed of stainless steel
- Die-cast aluminum LED heads

### Mounting

- Simple and easy to install on walls, poles, columns, struts also on vertical
- Pole or column installation bracket sold separately (order catalog number: PMK1-E)
- ½ NPT conduit entry on top or side

### Performance

- 6W, 10W and 15W high efficacy LED emergency heads
- 15W head outperforms traditional 50W MR16 halogen
- Innovative head design: four-LED and dual-driver provide illumination even in case of unexpected component failure

### Approvals

- UL924 Listed
- Can be installed in wide temperature range: -40°F to 131°F (-40°C to 55°C)

**Warranty** (subject to proper installation and maintenance)

Unit: five-year limited warranty

Detailed warranty terms located on [page 197](#) or online at: [www.lightalarms.com](http://www.lightalarms.com)



### Photometry performance

Capable of being installed indoors or outdoors, the SP Series of LED emergency lights deliver a stable and consistent illumination on the path of egress for a wide range of mounting heights. Depending on the required illumination levels need for the application, one choose between three level of lumen output using a 6W, 10W or 15W head.

LED Head	Power	Total lumens	Outperform spacing of MR16 halogen lamp types
L6	6W	565	37W PAR36, MR16 Halogen (700 Lumens)
L10	10W	1000	50W PAR36, MR16 Halogen (950 Lumens)
L15	15W	1300	50W MR16-IR Halogen (1550 Lumens)

### Spacing center-to-center (feet)

Mounting height	Lamp L6/6W, 565Lm	Lamp L10/10W, 1000Lm	Lamp L15/15W, 1300Lm
10 ft	80'	110'	140'
15 ft	70'	105'	135'
20 ft	60'	100'	130'
25 ft	50'	95'	120'

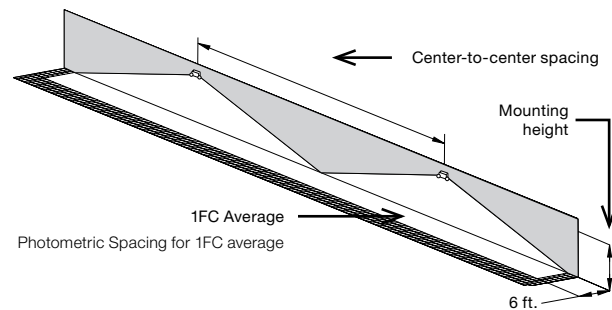

Industrial environment: Wall mounted equipment, reflectances: 10/10/10; 6-ft wide illumination path. Illumination as per NFPA101; Average: 1fc; Min: 0.1fc; Max/min < 40:1

**Dimensions** (Dimensions are approximate and subject to change):

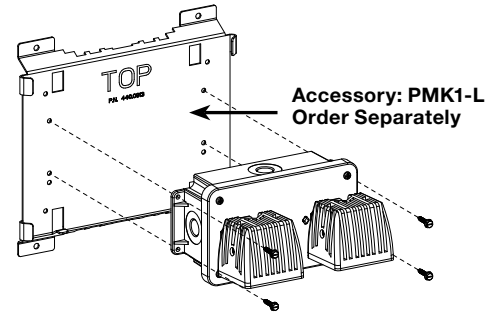
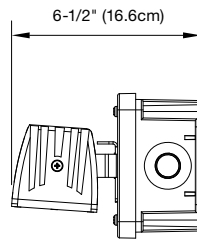
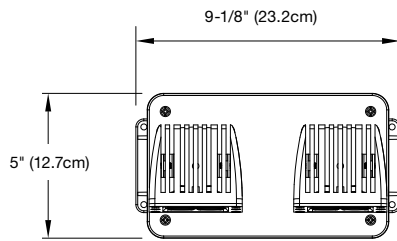

**Warning:** The mounting column must be anchored at both ends: floor and ceiling.

**Ordering format**

**Series**

**SPRL**= Severe performance remote fixture

**Number of heads**

**Blank**= Single head  
**D**= Double head

**LED head**

**L6**= 12-24V – 6W (565 Lumens)  
**L10**= 12-24V – 10W (1000 Lumens)  
**L15**= 12-24V – 15W (1300 Lumens)

**Example: SPRLDL6**

## SPH Series

Class I Division 2, Groups A, B, C and D, Class II Division 2 Groups F and G & Class III. NEMA-4X Severe-performance unit equipment for hazardous, damp and wet locations.



### Housing

- Class I, Div. 2, Groups A, B, C & D, Class II Div. 2, Groups F & G, Class III
- Fiberglass light-grey housing with captive screws; outside hardware in stainless steel
- NEMA-4X protection grade against liquids and dust
- Compact size: 0.46 cubic feet

### Mounting

- Simple and easy to install on walls, columns and struts
- For installation on columns use mounting bracket catalog number: PMK1-L (order separately)
- May be wired from top or side using conduit (½" NPT)

### Performance

- Wide ambient temperature range (choice of battery types) \*32°F to 122°F (0°C-50°C) high temperature Lead-Calcium battery \*50°F to 104°F (10°C to 40°C Nickel Cadmium battery Optional cold-weather -40°F (-40°C) (available with 12V battery models only)
- High-efficacy LED emergency lamps outperform traditional 50W halogen lamps
- Innovative lamp design: four-LED and dual-driver provide illumination even in case of unexpected component failure

### Testing option

- Infra-red remote control tester included in all models: allows testing the equipment without the need to climb a ladder. Distance range up to 30 ft. Universal, one Remote Control may test all the units on the job
- Non-Audible Improved Diagnostics and Self-test available
- Optional: Nexus® monitoring system available

### Approvals

- Listed UL924 and UL844 for hazardous locations: Class I Division 2, Groups A, B, C and D; Class II Division 2 Groups F & G and Class III; Rated NEMA-4X severe-performance for hazardous, damp and wet location.
- BC – California Energy Commission Title 20

### Warranty (subject to proper installation and maintenance)

Unit: five-year limited warranty

Detailed warranty terms located on **page 197** or online at: [www.lightalarms.com](http://www.lightalarms.com)

nexus

NEMA-4X

id  
Improved  
diagnostics



### Photometry performance

Capable of being installed indoors or outdoors, the SPH Series LED emergency lights deliver a stable and consistent illumination on the path of egress for a wide range of mounting heights.

LED Head	Power	Total lumens	Outperform spacing of MR16 halogen lamp types
L15	15W	1300	50W MR16 Halogen

### Spacing center-to-center (feet)

Mounting height	Lamp L15/15W, 1300Lm
10 ft	140'
15 ft	135'
20 ft	130'
25 ft	120'

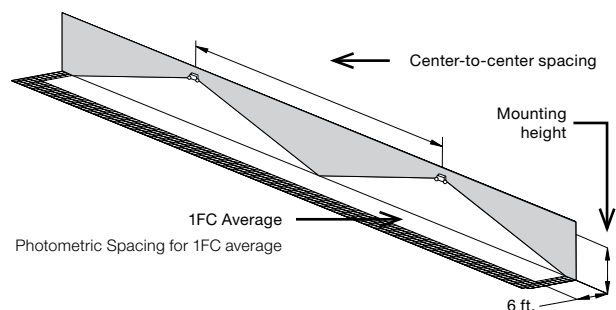

Industrial environment: Wall mounted equipment, reflectances: 10/10/10; 6-ft wide illumination path. Illumination as per NFPA101; Average: 1fc; Min: 0.1fc; Max/min < 40:1

**Dimensions** (Dimensions are approximate and subject to change)

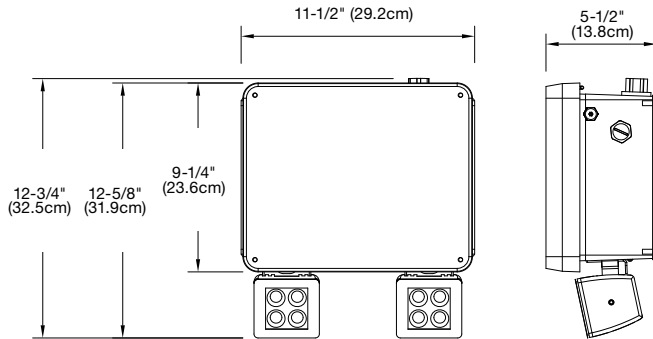

**PMK1-L Universal Mounting Bracket Installation**

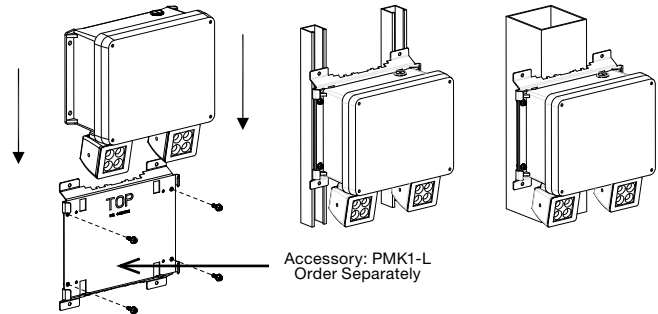

**Warning:** The mounting column must be anchored at both ends: floor and ceiling.

**Power consumption chart: maximum current draw**

Temperature	Specification
Standard temperature range	120/277VAC, 60Hz, 0.30/0.15A
Cold-weather option	120/277VAC, 60Hz, 0.70/0.35A

**Classification for hazardous locations**

Lamp rating	Temperature code	Maximum temperature	Replacement part number
		Nickel-cadmium Ta= 104°F/40°C	Lead-acid Ta= 122°F/50°C
L15 (15W)	Class I Division 2 Groups A, B, C and D	T3C	T3A
	Class II Division 2 Groups F and G; Class III	T5	T5
	Class I Division 2 Groups A, B, C and D		T4A
No heads	Class II Division 2 Groups F and G; Class III		T6

**Unit rating chart**

Series	Battery capacity in watts			
	90 minutes	2 Hrs	3 Hrs	4 Hrs
SPH12G3	30	20	15	10
SPH12G6	60	40	30	20
SPH12N4	40	36	24	18
SPH24N9	90	72	48	36

Note: the cold-weather option is only rated for 90 minutes.

**Remote test control (included with unit)**

Standard infrared remote test control tester included with all models: allow to test the equipment without need to climb a ladder. Functional up to 30 ft distance. Universal, one Remote Test Control can test all units on the job.



**Ordering format**

Series	Battery and Capacity	# of heads	LED heads	Diagnostics	Option	Approval
SPH12	<b>High Temperature Lead-Calcium</b> G3= 12V-30W, High temperature Lead-Calcium battery, Temperature= 32°F to 122°F (0...50°C)	0= No head 1= One head 2= Two heads	L15= 12-24V, 15W (1300 Lumens)	ID= Improved Diagnostics, audible <sup>1</sup>  IDNA= Improved Diagnostics, non-audible <sup>1</sup>	CW4= Cold-weather -40°F (-40°C) <sup>1</sup> T3= Time delay 15 minutes RFI= Radio frequency interference filter	-CEC= CEC Title 20 for California <sup>2</sup>
	SPH12	<b>Nickel-Cadmium</b> N4= 12V-40W, Nickel-Cadmium battery, Temperature= 50°F to 104°F (10...40°C)		NEX= Nexus® Wired (contact your sales representative) <sup>1</sup>  NEXRF= Nexus® Wireless (contact your sales representative) <sup>1</sup>  NID= No Improved Diagnostics, audible <sup>1</sup>		
SPH24	N9= 24V-90W, Nickel-Cadmium battery, Temperature= 50°F to 104°F (10...40°C)					

**Example: SPH12N402L15ID**

<sup>1</sup> Minimum load required: 20% of load capacity  
<sup>2</sup> Available with lead-calcium models only

## SPHRL Remote Fixture Series

Class I, Division 2, Groups A, B, C & D, Class II, Division 2, Groups F & G and Class III, NEMA-4X, damp & wet locations



BATTERY UNITS

### Housing

- Light weight polycarbonate gray housing and die-cast fully adjustable heads Class I, Div. 2, Groups A, B, C & D, Class II Div. 2, Groups F & G, Class III
- NEMA-4X protection grade
- All external fasteners and hardware are constructed of stainless steel
- Die-cast aluminum LED heads

### Mounting

- Simple and easy to install on walls, poles, columns, struts also on vertical pole or column installation bracket sold separately (order catalog number: PMK1-L)
- ½ NPT conduit entry on top or side

### Performance

- 15W high efficacy LED emergency heads outperform traditional 50W MR16-IR Halogen
- Innovative head design: four-LED and dual-driver provide illumination even in case of unexpected component failure

### Approvals

- UL924 Listed
- Can be installed in wide temperature range: -40°F to 131°F (-40°C to 55°C)
- Listed to the UL844 Standard for Class I, Division 2, Groups A, B, C & D, Class II, Division 2, Groups F & G and Class III

**Warranty** (subject to proper installation and maintenance)

Unit: five-year limited warranty

Detailed warranty terms located on **page 197** or online at: [www.lightalarms.com](http://www.lightalarms.com)



### Photometry performance

Capable of being installed indoors or outdoors, the SPHRL Series of LED remote emergency lights deliver a stable and consistent illumination on the path of egress for a wide range of mounting heights.

LED Head	Power	Total lumens	Outperform spacing of MR16 halogen lamp types
L15	15W	1300	50W MR16-IR Halogen

### Spacing center-to-center (feet)

Mounting height	Lamp L15/15W, 1300Lm
10 ft	140'
15 ft	135'
20 ft	130'
25 ft	120'

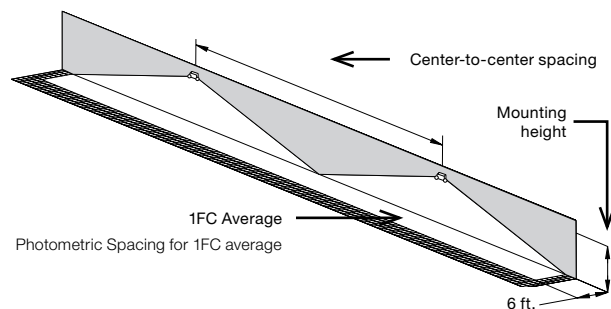

Industrial environment: Wall mounted equipment, reflectances: 10/10/10; 6-ft wide illumination path. Illumination as per NFPA101; Average: 1fc; Min: 0.1fc; Max/min < 40:1



**Dimensions** (Dimensions are approximate and subject to change)

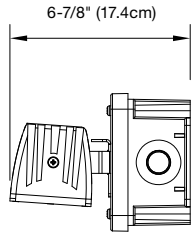
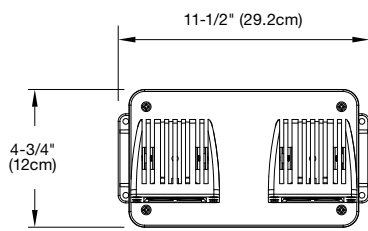

**PMK1-L Universal Mounting Bracket Installation**

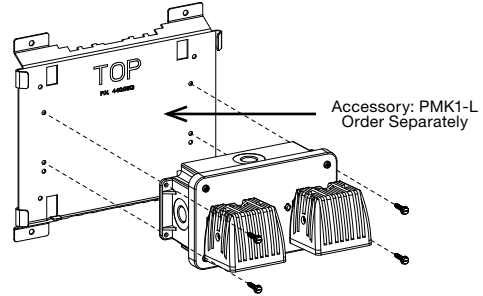

**Warning:** The mounting column must be anchored at both ends: floor and ceiling.

**Classification for hazardous locations**

Lamp suffix	Voltage	Power	Lumen flux	Ambient	Classification	Temperature code
L15	12-24VDC	15W	1,300 Lm	131°F (55°C)	Class I Division 2 Groups A, B, C and D	T3C
					Class II Division 2 Groups F and G; Class III	T5

**Ordering format**

Series	Number of heads	LED head
<b>SPHRL</b> = Severe performance hazardous location remote head	<b>Blank</b> = Single head <b>D</b> = Double head	<b>L15</b> = 12-24V – 15W (1300 Lumens)

**Example: SPHRLDL15**

## Severe™ VH Series

Class I, Division 2, Groups A, B, C and D 6V-18W & 12V up to 72W capacities  
lead-calcium battery



### The Severe™ VH Series Class I Division 2 Family



Severe™ XVHZ & XVEHZ exit series  
PG. 52-53



Severe™ XVH  
combo series  
PG. 54-55



Severe™ ELF651  
remote series  
PG. 140-141

#### Housing

- Class I Division 2, Groups A, B, C and D
- Vandal-resistant UV stabilized polycarbonate lamp cover
- Front and back plates are of a heavy duty aluminum
- Stainless steel tamper-proof screws

#### Mounting

- Surface wall mount only
- Includes mounting lugs on each side of the housing
- Universal J-Box mounting
- ½ inch entry on both sides and top of housing

#### Lamp type

Choice of MR16 LED lamp voltages and wattages

#### Electronics

- Pulse plus charger
- Low voltage disconnect
- Automatic brownout protection
- Battery lock-out
- Fused output circuit
- Magnetic test switch
- Standard Improved Diagnostics (non-audible)
- Optional: Nexus® monitoring system
- 120/277 60Hz

#### Photometric performance

Lamp	Spacing center-to-center (feet)	
	7 feet mounting height	15 feet mounting height
LD1	39'	34'
LD2	74'	57'
LD7	49'	39'
LD9	68'	54'
LD10	89'	80'

#### Battery type

6 or 12V Lead-Calcium battery

#### Approvals

- CSA-US (To UL 924 standards)
- Evaluated to the UL 844 Standard for Class I Division 2, Groups A, B, C and D
- NEC, OSHA and NEMA compliant for above Classes and Groups
- Damp and wet location 50°F to 104°F (10°C to 40°C)

#### Warranty (subject to proper installation and maintenance)

Unit: five-year limited warranty

Detailed warranty terms located on [page 197](#) or online at: [www.lightalarms.com](http://www.lightalarms.com)

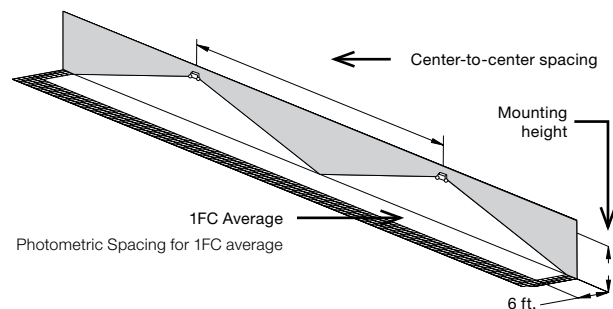

**Dimensions** (Dimensions are approximate and subject to change)

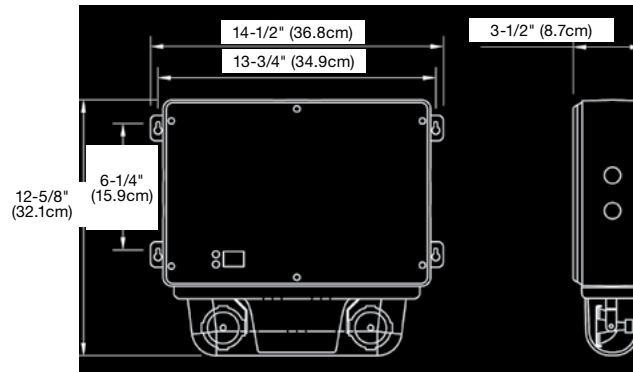

**Power consumption chart**

Series	Battery	Voltage	DC Specs				AC Specs	
			87.5% Battery capacity (in watts) <sup>1</sup>				Units dual voltage <sup>2</sup>	Current Maximum
			90 Mins	2 Hrs	3 Hrs	4 Hrs		
VHG1	Lead-Calcium	6V	18	12	9	0	120/277VAC	0.17A/0.09A
VH12G1		12V	36	27	18	14	120VAC 277VAC	0.3A 0.15A
VH12G2		12V	60	45	30	24		
VH12G3		12V	72	54	36	28		

<sup>1</sup> National Electrical Code Specification

<sup>2</sup> All units 120/277 dual voltage, information based on wiring to specific voltage type

**Accessories** (Order as a separate item)

Description	Product code
Wire guard	WG3-L

**Temperature codes: MR16 LED lamps**

Lamp suffix	Voltage	Wattage	Lumens	Max temperature	Replacement number
LD1	6	4	T4A	120°C	580.0097-L
LD2	6	5	T4A	120°C	580.0122-L
LD7	12	4	T4A	120°C	580.0093-L
LD9	12	5	T4A	120°C	580.0104-L
LD10	12	6	T4A	120°C	580.0106-L

**Ordering format**

Number of heads	Series	Lamp type	Color	Options
0= No heads 2= Two heads	<b>VHG1</b> = 6V-18W <b>VH12G1</b> = 12V-36W <b>VH12G2</b> = 12V-60W <b>VH12G3</b> = 12V-72W	<b>LD1</b> = 6V-4W, MR16 LED <b>LD2</b> = 6V-5W, MR16 LED <b>LD7</b> = 12V-4W, MR16 LED <b>LD9</b> = 12V-5W, MR16 LED <b>LD10</b> = 12V-6W, MR16 LED	<b>G</b> = Grey	<b>Blank</b> = Improved Diagnostics standard (non audible) <sup>1</sup> <b>-DA</b> = Improved Diagnostics (audible) <sup>1</sup> <b>-NEX</b> = Nexus® Wired (contact your sales representative) <b>-NEXRF</b> = Nexus® Wireless (contact your sales representative) <b>-T3</b> = Time delay (15 minute)

**Example: 2VHG1LD1G**

<sup>1</sup> -ID & -IDNA include a time delay feature that can be enabled/disabled in the field or set by the factory by including -ID-TD\* or -IDNA-TD\*

## EXP LED Series

Explosives/Hazardous location housing 6V up to 30W & 12V up to 40W capacities  
Nickel-Cadmium battery



Class I, Division 1 & 2, Group C & D  
Class II, Division 1 & 2, Group E, F & G  
Class III

### Housing

- One-piece heavy gauge, corrosion resistant, copper-free cast aluminum
- Consists of a housing with provisions for up to two lighting heads
- Spin-off gasketed cover prevents propagation of internally generated arcs
- Stainless steel vent/drain
- Lighting head fixtures are heavy cast aluminum with Pyrex® lens
- Exit faceplate: heavy-duty 20 gauge steel, baked enamel grey finish
- 6 inch EXIT lettering legend, available in red or green
- Field-selectable chevrons

### Mounting

- Surface wall mount
- 3/4" NPT conduit entry on top and bottom of housing
- Single and double pendant mount heads include elbow swivel, conduit extension pipe (6" increments)

### Electronics

- Pulse plus charger
- Low voltage disconnect
- Automatic brownout protection
- Battery lock-out
- Fused output circuit
- 120/277 60Hz

### Lamp type

- Heads offer a choice of MR16 LED lamp voltages and wattages
- Exit sign uses a 3 watt LED lamp

### Battery type

6V or 12V, Nickel-Cadmium battery

### Approvals

- CSA-US (To UL 924 standards)
- Manufactured in accordance with UL844, UL1203
- Class I, Division 1 & 2, Groups C and D
- Class II, Division 1 & 2, Groups E, F and G
- Class III
- NEC, OSHA and NEMA compliant for above Classes and Groups
- Temperature Code T6

**Warranty** (subject to proper installation and maintenance)

Unit: five-year full warranty

Detailed warranty terms located on **page 197** or online at: [www.lightalarms.com](http://www.lightalarms.com)



### Photometric performance

Lamp	Spacing center-to-center (feet)	
	7 feet mounting height	15 feet mounting height
2 X LD1	43'	29'
2 X LD2	70'	39'
2 X LD7	55'	36'
2 X LD9	67'	41'
2 X LD10	87'	62'

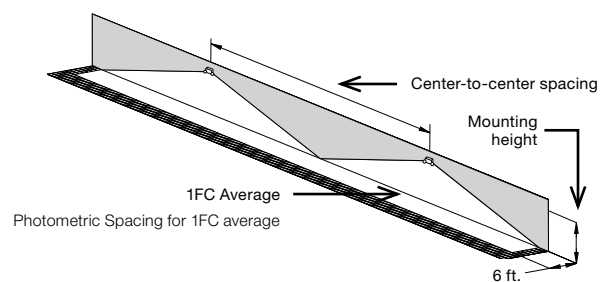

**Dimensions** (Dimensions are approximate and subject to change)

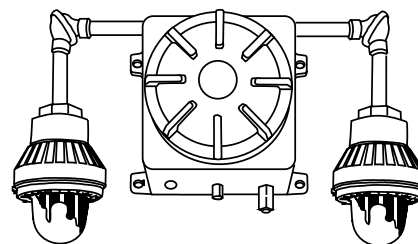

Housing: 12" X 12" X 9-1/2"  
Mounting Lugs: 10" and 13-1/2" on center  
Overall dimensions (including fixtures): 38" X 38" X 10"

**Power consumption chart**

Series	Battery	Voltage	DC Specs				Units dual voltage <sup>1</sup>	AC Specs
			Battery capacity in watts <sup>1</sup>					
			90 Mins	2 Hrs	3 Hrs	4 Hrs		
EXP618	Nickel-Cadmium	6V	18	12	9	6	120/277VAC	0.55/0.25 A
EXP630		6V	30	20	15	10		
EXP1224		12V	24	18	12	9		
EXP1240		12V	40	30	20	15		

<sup>1</sup> All units 120/277 dual voltage, information based on wiring to specific voltage type

**Standard configurations for EXP6N and EXP12N series**

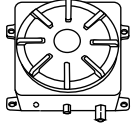
Unit	Catalog number	Description
	EXP618	6 Volt self contained hazardous location emergency battery unit 18 watts of remote capacity
Remote capability	EXP618-TS	6 Volt self contained hazardous location emergency battery unit 18 watts of remote capacity. Transfer switch included for use with remote Exit signs (maximum 5 Exits signs per TS)
Single head emergency unit	EXP1240E1LD9	12 Volt self contained hazardous location emergency battery unit with one head containing 2 X 2V 5W MR16 LED lamps, 30 watts of remote capacity
	EXP1240E1LD9-TS	12 Volt self contained hazardous location emergency battery unit with one head containing 2 X 12V 5W MR16 LED lamps, 30 watts of remote capacity. Transfer switch included for use with remote Exit signs (maximum 5 Exit signs per TS)
Double head emergency unit	EXP630E2LD1	6 Volt self contained hazardous location emergency battery unit with two heads, each containing 2 X 6V 4W MR16 LED lamps, 14 watts of remote capacity
	EXP630E2LD1-TS	6 Volt self contained hazardous location emergency battery unit with two heads, each containing 2 X 6V 4W MR16 LED lamps, 14 watts of remote capacity. Transfer switch included for use with remote Exit signs (maximum 5 Exit signs per TS)
Self-powered exit	EXP618-TSX1-LR	6 volt self contained exit sign with 15 watts of remote capacity. Transfer switch included for use with integral exit sign and additional remote exit signs (maximum 5 exit signs per TS).
Combination unit	EXP1230-E1LD10-TSX1-LR	12 volt self contained combination unit with 15 watts of remote capacity. Transfer switch included for use with integral exit sign and additional remote exit signs (maximum 5 exit signs per TS).

**Reflector/Guards**

Part #	Description
145.0016-L	Dome reflector
145.0017-L	Angle reflector
330.0125-L	Aluminum guard

**Ordering format**

Series	DC Voltage	Capacity	No. of heads and lamps	Lamp wattage/Type
EXP = Battery Unit/ Combo	6 = 6VDC 12 = 12VDC	18 = 18W (6V only) 30 = 30W (6V only) 24 = 24W (12V only) 40 = 40W (12V only)	Blank = No emergency head -E1= Single head, two lamps -E2= Two heads, two lamps each	LD1= 6V-4W, MR16 LED LD2= 6V-5W, MR16 LED LD7= 12V-4W, MR16 LED LD9= 12V-5W, MR16 LED LD10= 12V-6W, MR16 LED
Battery options	EXIT sign # of faces	EXIT sign lamp	EXIT sign letter color	
Blank= no transfer panel -TS= transfer panel (Required to supply remote exit sign only)	Blank= No exit sign X1= Single-face exit	Blank= no exit sign -L= LED exit sign	Blank= No exit sign R= Red G= Green	

**Example: EXP630E1LD1-TSX1-LR**

## LCA-2RHL Series

High output lithium LED battery unit



### Housing

- UV stabilized thermoplastic body
- Two adjustable high output LED lighting heads
- White finish

### Mounting

- Wall or ceiling mount
- Universal J-box mounting

### Lamp type

- Two 9.6V-5.4W LED heads, 550 lumens per head

### Electronics

- Pulse plus charger
- Low voltage disconnect
- Automatic brownout protection
- Battery lock-out
- Fused output circuit
- Standard Improved Diagnostics
- 120/277 60Hz

### Battery type

- 9.6V Lithium phosphate battery

### Photometric performance

Mounting height	Spacing center-to-center (feet)	
	6 ft spacing distance	
7.5'	90'	
10'	78'	

### Approvals

- UL 924 Listed
- Damp location (50°F to 104°F)
- UL 94, 5VA flame rated
- Circle BC meet CEC title 20

### Warranty

(subject to proper installation and maintenance)

Unit: three-year full warranty

Detailed warranty terms located on **page 197 of the catalog** or online at: [www.lightalarms.com](http://www.lightalarms.com)

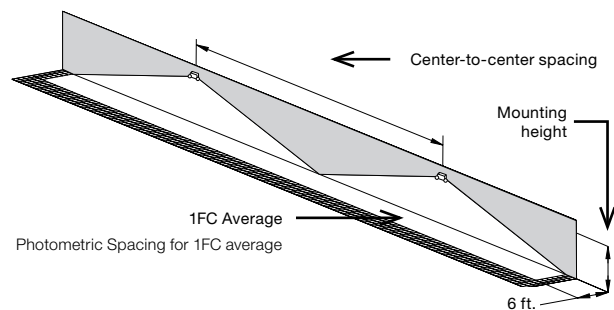

**Dimensions** (Dimensions are approximate and subject to change)

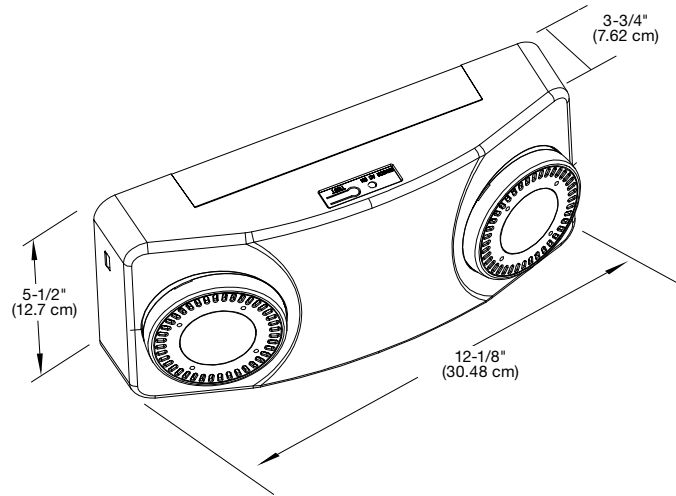

**Power consumption chart**

Series	DC Specs		AC Specs
	Battery	Voltage	Units dual voltage
LCA-2RHL-ID	Lithium-ion battery	9.6	120-277

**Ordering format**

Series	Heads
LCA	-2RHL-ID= Two round high output LED heads Improved Diagnostics

**Example: LCA-2RHL-ID**



#### REMOTE FIXTURES

A range of remote lamp types suit illumination and spacing requirements in architectural, commercial, and industrial locations. Remote fixtures in contemporary styles are ideal where subtle, code-compliant lighting is required. Flexible mounting options accommodate challenging installations with limited space. Power remotes with battery units or mini inverters for a complete lighting solution.



# Table of contents

## Remote Fixtures & Heads

					
<b>Introduction About remote fixtures</b>	<b>Architectural Recessed architectural RP Series</b>	<b>Architectural Vandal resistant linear dual-mode LSCN Series</b>	<b>Architectural Remote Fixture Decorative™ Series</b>	<b>Architectural Remote Fixture Phantom™ Series</b>	<b>Architectural Remote Fixture Saf-T-Ray™ Series</b>
120-121	122-123	124-125	126-127	128	129
					
<b>Architectural Remote Fixture Camray® LED Series</b>	<b>Architectural Remote Head &amp; Unit Head DR Series</b>	<b>Commercial Remote Head and Unit Head ELF3 Series</b>	<b>Commercial LCARDSQLED Series</b>	<b>Commercial ELF612D/LED Series</b>	<b>Commercial &amp; Industrial Vandal-resistant ELF640 Series</b>
130-131	132	133	134	135	136
					
<b>Commercial &amp; Industrial NEMA-4X ELF650 Series</b>	<b>Product sector NEMA-4X SPRL Series</b>	<b>Industrial Hazardous location ELF651 Series</b>	<b>Industrial Hazardous location EPF401 LED Series</b>		
137	138-139	140-141	142-143		

# About Remote Fixtures & Head Illumination

## Emergency Lighting Heads and the lamps they use: Illuminating a Path of Egress

Emergency Lighting Heads and the choice of lamps used within those heads is the most important element of an emergency lighting system's performance getting people to safety in an emergency situation. The light output or lumens provided by the lamp is a key factor in evacuating a building quickly and safely during an emergency situation, thus possibly saving lives. Providing the correct amount of light allows people to easily see their path of egress, saving precious seconds exiting a building in an emergency situation when every second counts. The Life Safety Code, which can be found at the back of this catalog, provides information on the minimum light levels that should illuminate a path of egress for safe evacuation, and the required foot candles at floor level. The lumen output of a lamp can provide different foot candle levels based on the mounting height of the lighting head or fixture. A photometric layout with the lighting heads mounted at the height of installation and the lamps being used will provide a visual estimation of the foot candle levels achieved at floor level. Emergency lighting heads should be installed to provide illumination along the path of egress of no less than an average of 1 footcandle, with no point at less than 0.1 footcandle. The heads should also be mounted in such a way that if one lamp should fail, it will not leave an area with less than 0.2 foot candle of illumination. Local and state codes may have other requirements. It is always good practice to check with the appropriate inspector about the illumination required.

## Important considerations when choosing the proper lamp

Emergency Lighting is required to provide illumination for a minimum of 90 minutes or an hour and a half during an emergency situation. Emergency Lighting lamps powered from a DC battery source must be powered by a battery that has the capacity to power all the lamps using that battery source for a minimum of 90 minutes. It is important to choose the correct lumen output lamp to meet the required illumination at the floor level on a path of egress. It is equally important to match the lamp and the battery voltages. If you do not have a battery that is the same voltage as the lamp and with enough wattage capacity to illuminate all the lamps, then the lamps will not provide adequate lumen output for 90 minutes to meet the required illumination at floor level along the path of egress. First, match voltage. The voltage of the lamp MUST exactly match the voltage of the battery powering that lamp. If the voltage of the battery is lower than the voltage of the lamp, the lamp may not illuminate. If the voltage of the battery is higher than the voltage of the lamp, the lamp may "pop". Second, consider total wattage. The wattage of each individual lamp drawing from a battery during emergency operation, including the lamps mounted on the unit as well as all remote lamps wired to that unit, added together, CAN NOT EXCEED the total wattage capacity of that battery within 90 minutes of operation. A unit's battery wattage capacities are shown in the Unit Rating Chart of each particular unit. Available lamp types are shown on the Lamp Selection Chart on the catalog page for each head style or fixture type. Lamp Selection Chart information refers to a single lamp. If you are using a double or triple lamp type head or fixture, the wattage draw of that head or fixture will be the total number of lamps used. For example, if you are using a double lamp fixture with a 12W lamp, that fixture will have a 24W draw (two lamps of 12W each,  $12W + 12W = 24W$  total).

## Remote Fixtures Series

### Emergency lighting

#### Lamp Life

It is often asked why emergency lighting lamps have such a short lamp life. Who wants a lamp that only lasts 50 hours? However, considering that most of the time emergency lighting lamps are not illuminated, 50 hours is not such a short life. If power failures are relatively scarce; for example, 90 minutes 4 times a year, then emergency lighting would only be required for six hours. If you add in monthly testing and a 90-minute annual test, that lamp would be illuminated for an average of 8 hours a year. Based on that example, a lamp with a 50-hour life is more than adequate for emergency lighting. By design, some emergency lighting lamps are made to burn brighter using the same wattage draw as lamps that could have a longer life but not burn as bright. A brighter burn lamp has a shorter life, but in an emergency situation, the brighter the better. Lamp improvements are continuously being made to make them brighter, draw less wattage, increase lumen efficacy per watt, and provide longer life. LED lamps have taken emergency lighting lamps to a whole new level. For example, our 12V-6W MR16 LED lamp provides 540 lumens with a lamp life of over 30,000 hours.

#### Lamp Types:

**MR16 LED** The MR16 LED lamp contains everything in one small package: long-life, high lumen output, and a high lumens-to-watts efficacy ratio. An MR16 lamp is easy to install and replace if needed – just push it in or pull it out of the lamp socket. Our 12V-6W MR16LED lamp has a lumen output of 540 for an average spacing of 100 feet center-to-center. With an efficacy of 91.9 lumens per watt, that's 3 times the efficacy of an MR16 20W high-output lamp. An MR16 LED lamp has a life of over 30,000 hours.

The Phantom™ Series  
Virtually invisible  
emergency lighting.



## RPR Series

Remote recessed architectural fixture



### Construction

- Thermoplastic rectangular fixture with additional round trim-plate, white finish
- All-metal backbox enclosure
- Fixed optics, optimized light distribution for ceiling heights up to 12 ft.
- Four high-intensity LEDs with redundant connections; 140 lm/W, CCT 5000K

### Options

- Plenum-rated enclosure
- Black thermoplastic decorative trim-plates
- Fixed, square light distribution pattern

### Mounting

- Easily spring mounted in sheetrock ceiling
- Recessed installation in T-bar suspended ceilings

### Electronics

- AC model compatible with Lightalarms® mini inverters
- DC model available with Lightalarms® 6-24 battery units

### Approvals

- Listed UL-924 for damp locations: 50° to 104°F (10° to 40°C)
- Listed NSF, splash non-food zone

### Warranty (subject to proper installation and maintenance)

Unit has a five-year limited warranty

Detailed warranty terms located online at: [www.lightalarms.com](http://www.lightalarms.com)



REMOTES & HEADS

### Photometric performance

The RPR Series has a fixed lighting distribution, optimized by design for ceiling heights up to 12 ft. Along an office corridor the space coverage ranges from 68 to 80 feet. The square distribution pattern option covers a surface of more than 700 square feet.

Table A: Standard unit 6-ft wide corridor<sup>1</sup>

Mounting height	Spacing center-to-center
9 ft	68 ft
10 ft	80 ft
12 ft	72 ft

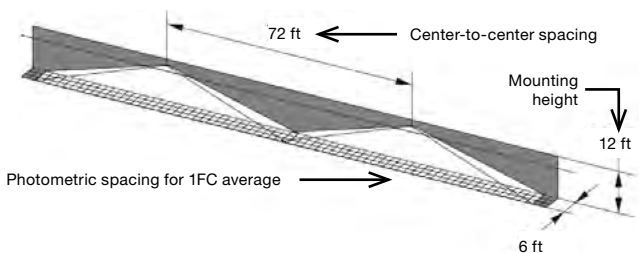
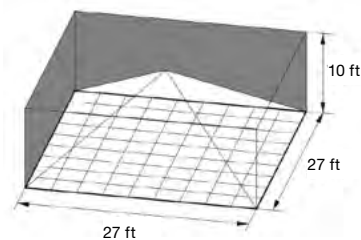

Table B: Option “square distribution pattern” – single unit coverage<sup>1</sup>

Mounting height	Room size	Room surface
10 ft	27 ft x 27 ft	729 square feet

<sup>1</sup>Note: Illumination levels as per the Life Safety Code (NFPA 101): Average 1 fc, Minimum 0.1 fc, Max-to-min ratio 40:1. Typical reflectance levels of walls/ceiling/floor: 80/50/20.



**Dimensions** (Dimensions are approximate and subject to change)

**Recessed suspended ceiling mount**

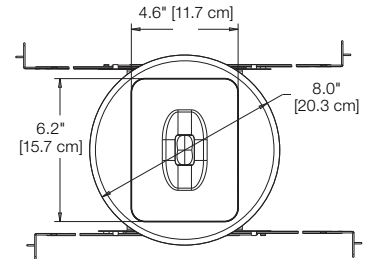
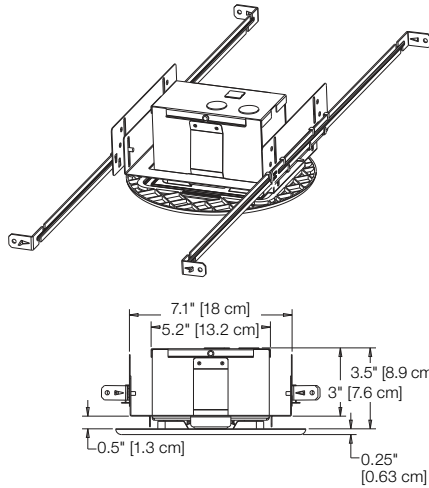
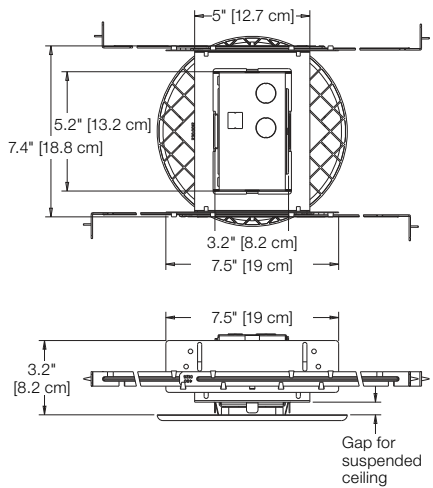

**Recessed sheetrock ceiling mount**

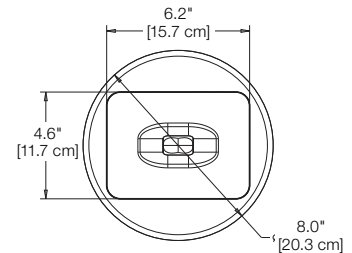
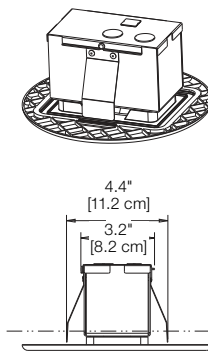
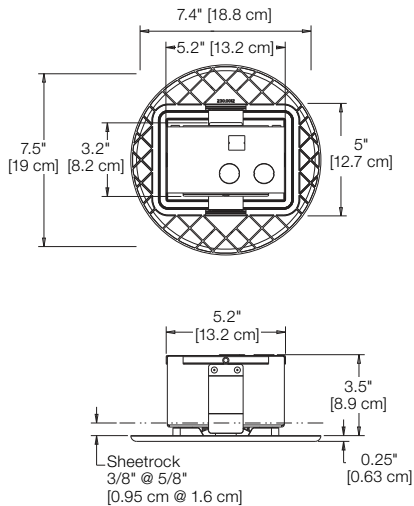

**Power consumption and unit rating**

AC Input (VAC)	Input current (A)	Input power (W)	Power factor
120	0.060		
240	0.030	7.0	0.95
277	0.025		

DC Input voltage (VDC)	Input power (W)
6-24	6.5

**Ordering format**

Series	Color	Voltage	Options
RPR= Recessed plastic remote fixture	B= Black W= Factory white	AC= 120 to 277VAC, 50/60Hz DC= 6 to 24VDC	Blank= No options P= Plenum/Type IC rated SQ= Square distribution pattern

**Example: RPRWACSQ**

## LSCN Series

### Vandal resistant linear remote fixture



#### Housing

- White high impact thermoplastic housing
- Frosted lens

#### Mounting

- Standard surface ceiling and wall mount
- Optional accessory: semi-recessed ceiling mount

#### LED information

- Easily adjustable LED strips for multiple beam angles
- Color temperature: 4000K
- 1200-1300 lumen output

#### Electronics

- Universal voltage 120V through 277V 60Hz. 12-24VDC
- Compatible with Lightalarms® 12 and 24V battery units

#### Approvals and ratings

- Rated for -4°F to 113°F (-20°C to 45°C)
- Suitable for wet locations
- Meets IP65 rating
- Meets IK10 rating requirements<sup>1</sup>
- ROHS compliant
- UL924 approved

#### Warranty (subject to proper installation and maintenance)

Unit has a three-year warranty

Detailed warranty terms located **online at: [www.lightalarms.com](http://www.lightalarms.com)**

<sup>1</sup>IK ratings refer to impact tests. IK10= Protected against 20 joules of impact (equivalent to 11lbs. of mass dropped from 16" high)



#### Spacing

Mounting type	Spacing at 9ft mounting	Lumens
Ceiling mount	62'	1300
Wall mount	53'	1200

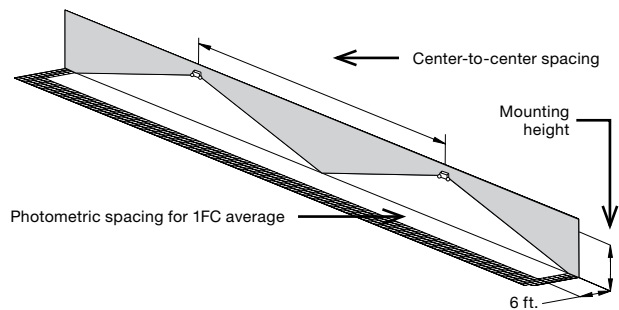

**Dimensions** (Dimensions are approximate and subject to change)

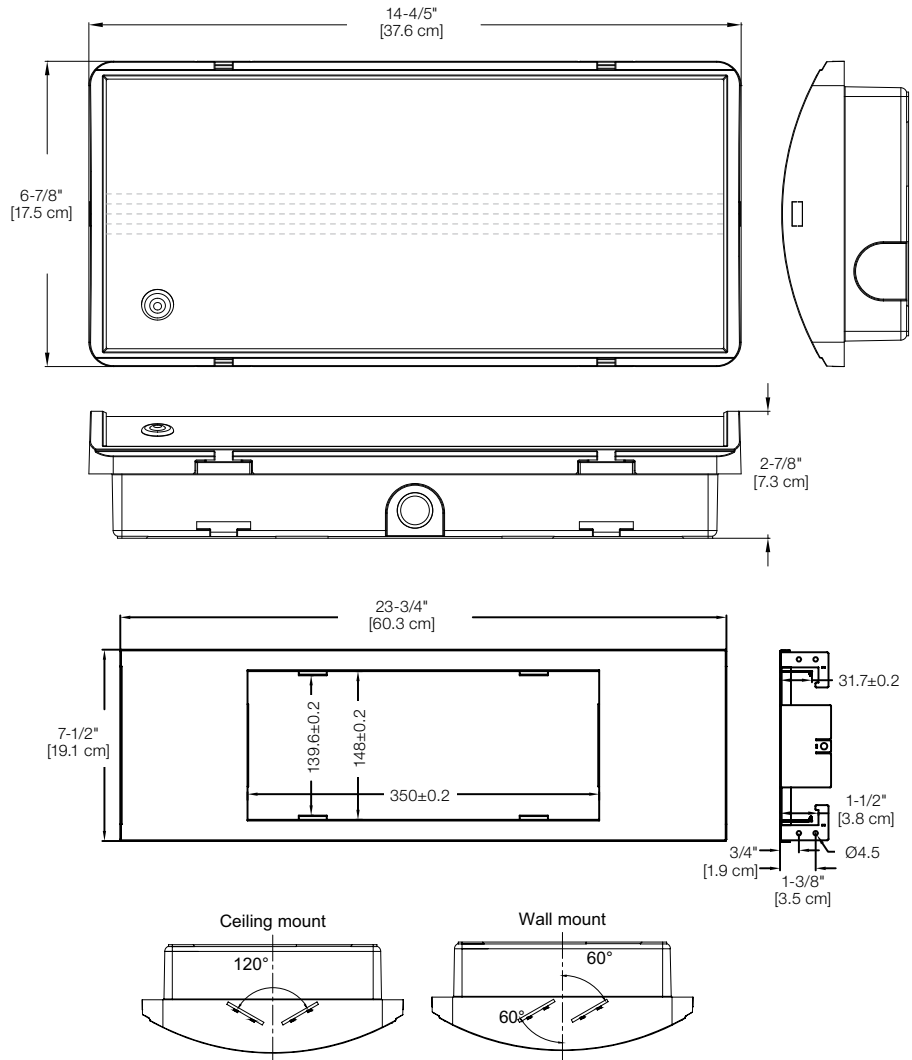

REMOTES & HEADS

**Power consumption**

	Voltage	Wattage
AC	120-277VAC	14 watts
DC	12-24VDC	13 watts

**Accessories** (order as a separate item)

Description	Product code
Semi recessed mounting bracket	KIT-SR-LA

**Ordering format**

**Series**

LSCN= Remote linear

-ACDC= ACDC 120-277VAC, -12-24VDC

**Example: LSCN-ACDC**

## Remote Fixture Decorative™ Series

Contemporary and enduring style



### Description

- Indoor use
- Die cast aluminum construction

### Finish

Powder-coated off-white, black or brushed nickel

### Lamp type

Choice of MR16 LED lamp wattages

### Mounting

- Recessed Mount
- Must order appropriate housing with decorative head selection for installation into new construction ceiling (LU-GRHR03) or non-insulated ceiling (LU-GRHR05) GU10 or Insulated ceiling (LU-GRHR06)

### Approval

UL 924 Listed

### Warranty

(subject to proper installation and maintenance)

Unit: three-year full warranty

Detailed warranty terms located on [page 197](#) or online at: [www.lightalarms.com](http://www.lightalarms.com)



### Series

	<b>RSTH18R:</b> concave (egress/ regress)	<b>Description:</b> Decorative lighting head
		<b>Dimensions:</b> 4.0" diameter base
		<b>Color Suffix:</b> -WH = White or -BN = Brushed Nickel, -BK= Black
	<b>RSTH19:</b> pop-out	<b>Description:</b> Decorative lighting head
		<b>Dimensions:</b> 4.0" diameter base
		<b>Color Suffix:</b> -WH = White, -BK= Black
	<b>LU-GRHR03</b>	<b>Housing Enclosure Description:</b> New construction housing
		<b>Dimensions:</b> 5.6" x 14.24"
	<b>LU-GRHR05</b>	<b>Housing Enclosure Description:</b> New construction housing New construction housing for GU10 (MR16 120V)
	<b>LU-GRHR06</b>	<b>Housing Enclosure Description:</b> Insulated ceilings housing
		<b>Dimensions:</b> 7.25" x 14.24"

### Photometric performance

Lamp	Spacing center-to-center (feet)	
	7 feet mounting height	15 feet mounting height
LD1	43'	36'
LD2	81'	64'
LD7	55'	43'
LD9	71'	56'
LD10	100'	85'
LD13	56'	44'
LD14	100'	85'
LD26	43'	39'

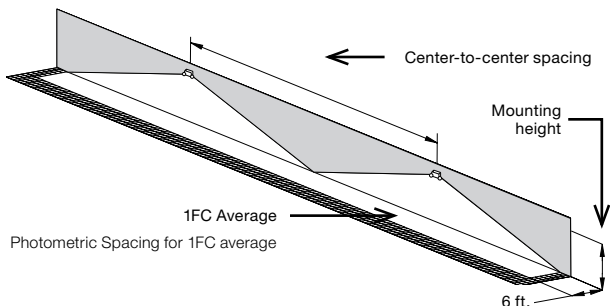



**Dimensions** (Dimensions are approximate and subject to change)

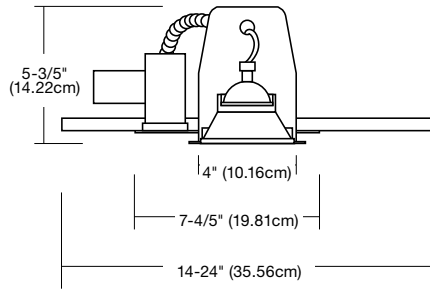

**LU-GRHR03**

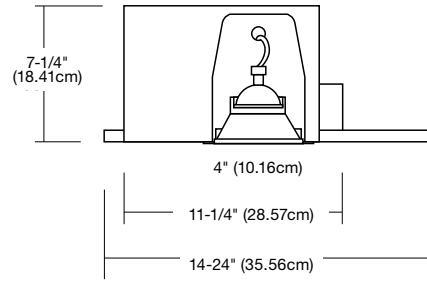

**LU-GRHR06**

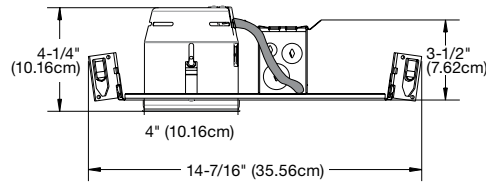

**LU-GRHR05**

**Lamp selection chart – MR16 LED lamps**

Lamp suffix	Voltage	Wattage	Lumens	Replacement #
LD1	6	4	130	580.0097-L
LD2	6	5	415	580.0122-L
LD7	12	4	170	580.0093-L
LD9	12	5	340	580.0098-L
LD10	12	6	540	580.0106-L
LD13	24	4	200	580.0104-L
LD14	24	6	590	580.0100-L
LD26	120	4	200	580.0113-L

**Ordering format**

Series	Lamp suffix	Color	Voltage
RSTH18R	/_____ <sup>1</sup>	<b>WH</b> = White	<b>6</b> = 6 VDC
RSTH19		<b>-BK</b> = Black	<b>12</b> = 12 VDC
		<b>-BN</b> = Brushed nickel (available with RSTH18R only)	<b>24</b> = 24 VDC
			<b>120</b> = 120 VAC/VDC

**Example: RSTH18R/LD9-WH and LU-GRHR03**

With Housing Enclosure Example: LU-GRHR06 (for Insulated Ceiling installation)

<sup>1</sup> Choose from lamp selection chart

# Remote Fixture Phantom™ Series

Virtually invisible, architecturally pleasing



### Description

- Indoor use
- One-piece all-metal module design
- Complete 360° door rotation
- Slip gear mechanism protects the unit from objects that would cause the door rotation to be forcibly stopped.

### Finish

- Flat door and frame are covered with a high-quality, powder coated textured mist white finish
- Surface finish can be customized on site with paint, wallpaper or other coverings.

### Mounting

- The module includes the electrical junction box and is installed on the wall stud or ceiling beam with the help of a simple, U-shape bracket.
- Key-hole slot for ease of installation

### Lamp type

Choice of MR16 LED lamp voltages and wattages

### Approval

- CSA-US (to UL 924 standards)
- New York City Approved

### Warranty (subject to proper installation and maintenance)

Unit: five-year full warranty

Detailed warranty terms located on page 197 or online at: [www.lightalarms.com](http://www.lightalarms.com)



### Dimensions (Dimensions are approximate and subject to change)

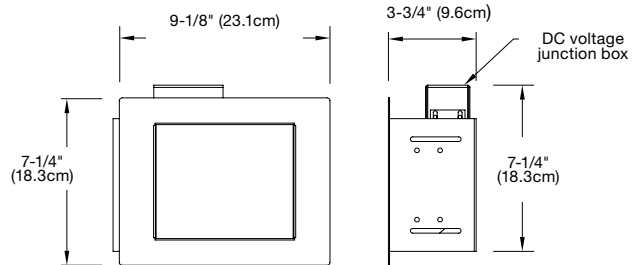

### Photometric performance

Lamp	Spacing center-to-center (feet)	
	7 feet mounting height	15 feet mounting height
LD7	39'	34'
LD9	49'	39'
LD10	68'	54'
LD13	89'	80'

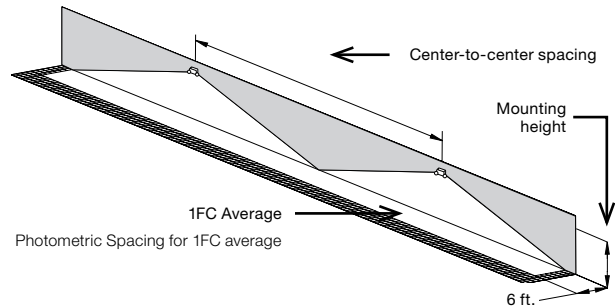

### Lamp selection chart – MR16 LED lamps

Lamp suffix	Voltage	Wattage	Lumens	Replacement #
LD7	12	4	170	580.0093-L
LD9	12	5	340	580.0101-L
LD10	12	6	540	580.0106-L
LD13	24	4	200	580.0098-L

### Ordering format

Series	Lamp suffix	Options
12PMR2= 12 VDC <sup>1</sup>		DL= Damp location
24PMR2= 24 VDC <sup>1</sup>	_____ <sup>2</sup>	
<b>Example: 12PM2R-LD10</b>		

<sup>1</sup> Double lamp remote fixture  
<sup>2</sup> Choose from lamp selection chart

## Remote Fixture Saf-T-Ray™ Series

Wall mount remote fixture for damp and wet locations



**Dimensions** (Dimensions are approximate and subject to change)

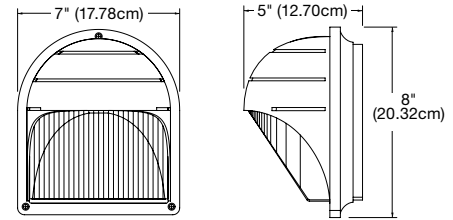

### Description

- Indoor or Outdoor use
- Die-Cast aluminum construction
- Fully gasketed cover
- Impact- and tamper-resistant polycarbonate lens

### Mounting

- Surface Wall Mount
- Universal J-Box mounting

### Lamp type

Choice of MR16 LED lamp voltages and wattages

### Approval

- UL 924 Listed
- NEMA-3
- Damp and wet location listed 50°F to 104°F (10°C to 40°C)

**Warranty** (subject to proper installation and maintenance)

Unit: three-year full warranty

Detailed warranty terms located on page 197 or online at: [www.lightalarms.com](http://www.lightalarms.com)



### Photometric performance

Lamp	Spacing center-to-center (feet)	
	7 feet mounting height	
LD7 (clear lens)	28'	
LD7 (frosted lens)	16'	

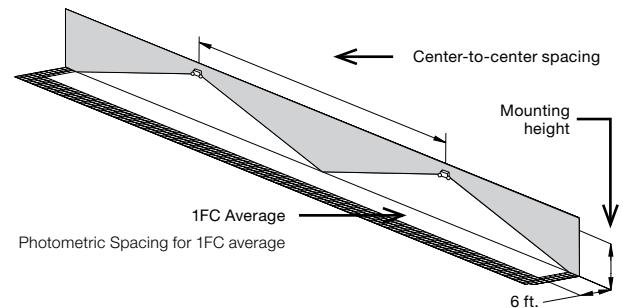

### Lamp selection chart – MR16 LED lamps

Lamp suffix	Voltage	Wattage	Lumens	Replacement #
LD1	6	4	130	580.0097-L
LD2	6	5	415	580.0122-L
LD7	12	4	170	580.0093-L
LD9	12	5	340	580.0098-L
LD10	12	6	540	580.0106-L
LD13	24	4	200	580.0104-L
LD25	120	4	200	580.0113-L

### Ordering format

Series	Lamp suffix	Color	Voltage	Options
SAF-2= Double lamp remote fixture	/ _____ <sup>1</sup>	-M= Mist white -B= Black -DG= Dark Gray	6= 6 VDC 12= 12 VDC 24= 24 VDC 120= 120 VAC/VDC	-VR= Vandal resistant screws -C= Clear lens
<b>Example: SAF-2/LD1-M6</b>				

<sup>1</sup>Choose from lamp selection chart

## Remote Fixture Camray® LED Series

Low-profile, slim look and performance in a remote fixture



### Unit color

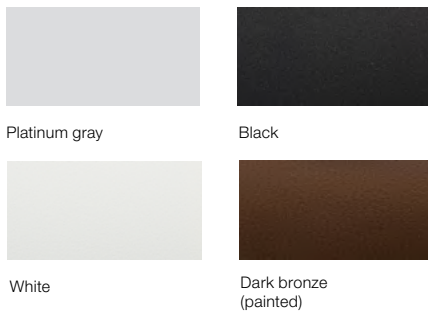

### Description

- Die-cast aluminium housing
- UV resistant polycarbonate lens

### Lamp type

- LED light engine with redundant connections
- Optional forward-throw light distribution, for applications of outdoor egress
- Optional dual-mode: normal and emergency LED lighting with separate AC inputs
- Optional high-lumen output
- Optional photo-switch: dusk-to-dawn control of normal lighting
- Optional remote test: infrared remote control
- 400-640 lumens
- Color temperature: 4000K

### Mounting

- Surface wall mount
- Universal J-Box mounting

### Approval

- UL 924 Listed
- NEMA-3R
- Damp and wet location listed 50°F to 104°F (10°C to 40°C)

**Warranty** (subject to proper installation and maintenance)

Unit: five-year full warranty

Detailed warranty terms located on [page 197](#) or online at: [www.lightalarms.com](http://www.lightalarms.com)



**Table A – Spacing for NFPA101 (average = 1FC) – Average of 1 foot-candle**

Model type	Mounting height	Lumen	Color temperature	Width X length (ft)	
				Single unit	Center-to-center
Standard	9'	400	4000K	6' X 50'	6' X 50'
With option -H	11'	550		6' X 60'	6' X 60'
With option -FT	12'	460			6' X 70'
With option -FTH	15'	640		6' X 40'	–
				6' X 40'	–

Indoor reflectance: 80/50/20 and 10-ft wide corridor.  
Outdoor reflectance: 0/30/10

**Table B – Spacing for minimum illumination = 1FC – Minimum of 1 foot-candle**

Model type	Mounting height	Lumen	Color temperature	Width X length (ft)	
				Single unit	Center-to-center
Standard	9'	400	4000K	6' X 28'	6' X 32'
With option -H	11'	550		6' X 32'	6' X 40'
With option -FT	12'	460			–
With option -FTH	15'	640		6' X 22'	–
				6' X 27'	–

Note: The illumination level meets ALL the requirements of the Life Safety Code (NFPA 101):  
1) Average of 1 foot-candle or more  
2) Minimum at any point of 0.1 foot-candle or more  
3) Maximum-to-minimum illumination uniformity ratio of 40:1 or less

### Photometry performance - Wide beam

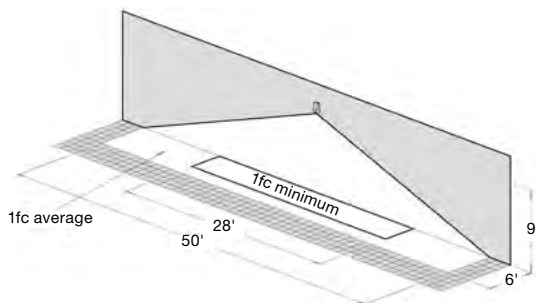

### Photometry performance - Forward throw

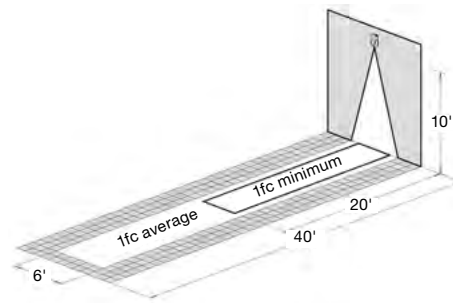

**Dimensions** (Dimensions are approximate and subject to change)

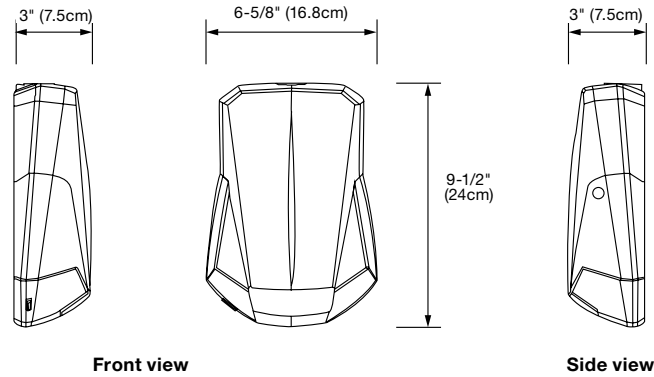

**Power consumption chart**

Model	AC input(s): 120/277VAC				DC input
	Normal lighting		Emergency lighting		6-12V
	Current (max.)	Power (max.)	Current (max.)	Power (max.)	Power (max.)
AC, 2AC, ACDC, DC	0.12/0.08A	12W	0.11/0.08A	12W	8W
All above, -H	0.18/0.11A	18W	0.18/0.11A	18W	14W (6VDC only)

**Ordering format**

Series	Model <sup>1</sup>	Color	Options
<b>CAM</b> = Camray® LED	<b>AC</b> = AC-only <b>ACDC</b> = AC/6-12VDC remote <b>DC</b> = 6-12VDC remote fixture <b>2AC</b> = AC-only two circuits: 120/120 or 277/277V	<b>B</b> = Black <b>DB</b> = Dark bronze <b>OW</b> = Off white <b>PG</b> = Platinum gray	<b>-FT</b> = Forward throw lighting <b>-H</b> = High lumen output -40°F - 86°F (-40°C - 30°C) <b>-P</b> = Photo-switch (AC and ACDC only) <b>-RC</b> = Remote control - infrared (AC and ACDC only) <sup>2</sup>

**Example: CAMACDCB-H**

<sup>1</sup> Temperature range: -40°F - 122°F (-40°C + 50°C)

<sup>2</sup> With -RC option, order the remote control keypad (TB-RC1-L) separately

## Remote Head & Unit Head DR Series

Decorative metal MR16 lamp head



### Description

- Indoor use
- Powder-coated die cast aluminum construction

### Finish

Mist-white or black

### Lamp type

Choice of MR16 LED lamp voltages and wattages

### Mounting

- Surface mount
- Universal J-Box mounting

### Warranty (subject to proper installation and maintenance)

Unit: three-year full warranty

Detailed warranty terms located on [page 197](#) or online at: [www.lightalarms.com](http://www.lightalarms.com)



### Accessories (Order as a separate item)

Description	Product code
Wire Guard for DR1130, DR2130	WG8-L
Wire Guard for DR3130	WG2-L

### Ordering format

Series	Lamp suffix	Color
DR1130= Single head		-WH= White
DR2130= Double head	/_____ <sup>1</sup>	-BK= Black
DR3130= Triple head		

**Example: DR1130/LD12-WH6**

<sup>1</sup>Choose from lamp selection chart

### Dimensions (Dimensions are approximate and subject to change)

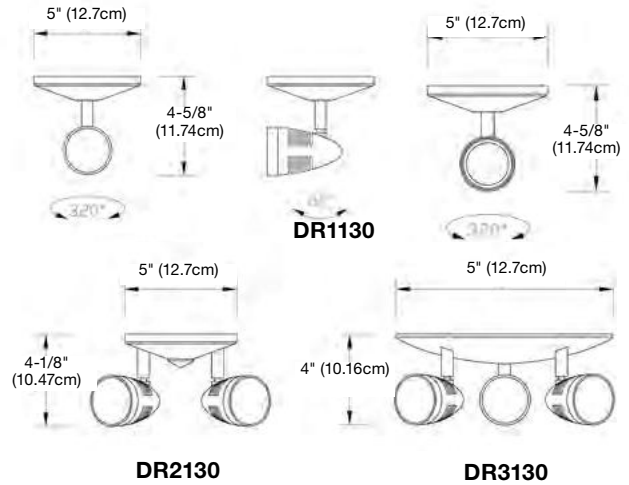

### Photometric performance

Lamp	Spacing center-to-center (feet)	
	7 feet mounting height	15 feet mounting height
LD1	43'	36'
LD2	81'	64'
LD7	55'	43'
LD9	71'	56'
LD10	100'	85'
LD13	56'	44'
LD14	100'	85'
LD25	43'	39'

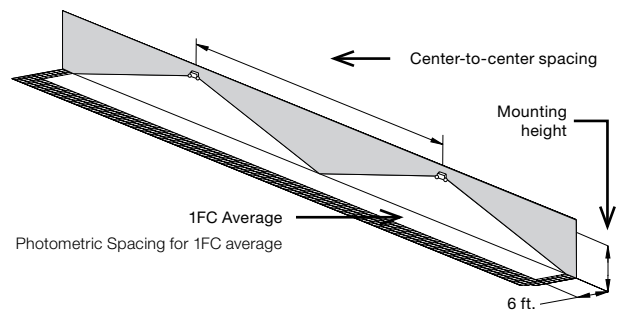

### Lamp selection chart – MR16 LED lamps

Lamp suffix	Voltage	Wattage	Lumens	Replacement #
LD1	6	4	130	580.0097-L
LD2	6	5	415	580.0122-L
LD7	12	4	170	580.0093-L
LD9	12	5	340	580.0104-L
LD10	12	6	540	580.0106-L
LD13	24	4	200	580.0098-L
LD14	24	4	590	580.0100-L
LD25	120	6	200	580.0010-L

## Remote Head & Unit Head ELF3 Series

Thermoplastic MR16 lamp head



### Description

- Indoor use
- Available as a single, double or triple head
- Thermoplastic construction
- Snap-out lens for easy lamp replacement

### Finish

Mist-white or black

### Lamp type

Choice of MR16 LED lamp voltages and wattages

### Mounting

- Surface Mount
- Universal J-Box mounting

### Approval

UL 924 Listed

### Warranty

(subject to proper installation and maintenance)  
Unit: three-year full warranty

Detailed warranty terms located on page 197 or online at: [www.lightalarms.com](http://www.lightalarms.com)



### Lamp selection chart – MR16 LED lamps

Lamp suffix	Voltage	Wattage	Lumens	Replacement #
LD1	6	4	130	580.0097-L
LD2	6	5	415	580.0122-L
LD7	12	4	170	580.0093-L
LD9	12	5	340	580.0104-L
LD10	12	6	540	580.0106-L
LD13	24	4	200	580.0098-L
LD14	24	6	590	580.0100-L

### Ordering format

Series	# of heads	Lamp suffix	Color	Voltage
ELF3= MR16 Par18 head	<b>Blank</b> = Single head <b>D</b> = Double heads <b>T</b> = Triple heads	/ _____ <sup>1</sup>	<b>-B</b> = Black <b>-M</b> = Mist white	<b>6</b> = 6 VDC <b>12</b> = 12 VDC <b>24</b> = 24 VDC
<b>Example: ELF3/LD1-B6</b>				

<sup>1</sup>Choose from lamp selection chart

### Dimensions

(Dimensions are approximate and subject to change)

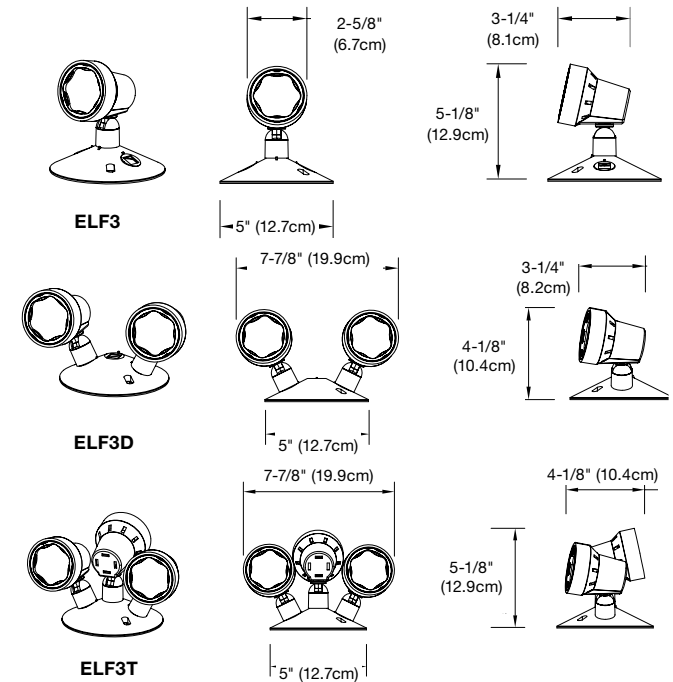

### Photometric performance

Lamp	Spacing center-to-center (feet)	
	7 feet mounting height	15 feet mounting height
LD1	43'	36'
LD2	81'	64'
LD7	55'	43'
LD9	71'	56'
LD10	100'	85'
LD13	56'	44'
LD14	100'	85'

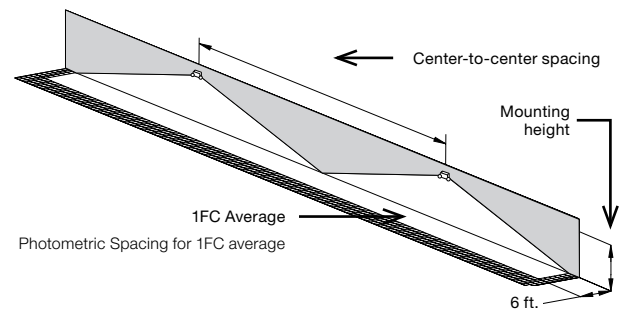

### Accessories

Description	Product code
Wire Guard	WG8-L

## LCARDSQLED Series

Thermoplastic square LED indoor remote heads



### Housing

- Thermoplastic dual head remote
- Wall or ceiling mount

### Only used with

- LCAC-2SQLEDR
- LCAC-2SQLEDRID
- LCA-2SQLEDR
- LCA-2SQLEDRID

### Lamp information

- LED 3.6V, 2W total
- 6000K LED color temperature

### Approvals

- Damp location listed
- UL924 Listed

**Warranty** (subject to proper installation and maintenance)

Unit: three-year full warranty

Detailed warranty terms located on page 197 or online at: [www.lightalarms.com](http://www.lightalarms.com)



### Ordering format

Series	Head style / Lamp type	Options
LCAR	D= Double	SQLED= Thermoplastic square LED head

**Example: LCARDSQLED**

### Dimensions (Dimensions are approximate and subject to change)

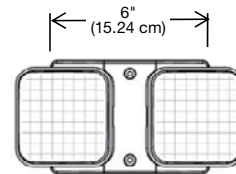

### Photometric performance

Spacing center-to-center (feet)	
7 feet mounting height	15 feet mounting height
13'	4'

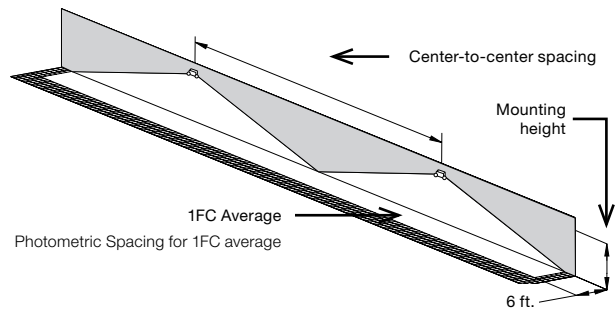



## ELF612D/LED Series

Thermoplastic square LED outdoor remote heads



### Housing

- ELF612D/LED remote series is multi-volt 3.6, 6 or 12V, 3W total
- Thermoplastic housing and aluminum canopy with fully adjustable LED heads
- Suitable for outdoor application
- Suitable for wet location applications
- Wall or ceiling mount

### Approvals

UL924 Listed

**Warranty** (subject to proper installation and maintenance)

Unit: three-year full warranty

Detailed warranty terms located on [page 197](#) or online at: [www.lightalarms.com](http://www.lightalarms.com)



**Accessories** (Order as a separate item)

Description	Product code
Wire Guard (heads in any position) wall mount	WG10-L

### Ordering format

Series	# of heads	Options	Color
ELF612	<b>Blank</b> = Single head <b>D</b> = Double heads	<b>/LED</b> = Thermoplastic square LED head	<b>Blank</b> = Gray <b>Bk</b> = Black

**Example:** ELF612D/LED

**Dimensions** (Dimensions are approximate and subject to change)

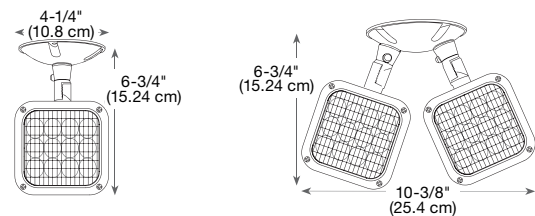

### Photometric performance

Lamp	Spacing center-to-center (feet)	
	7 feet mounting height	15 feet mounting height
ELF612	13	4'

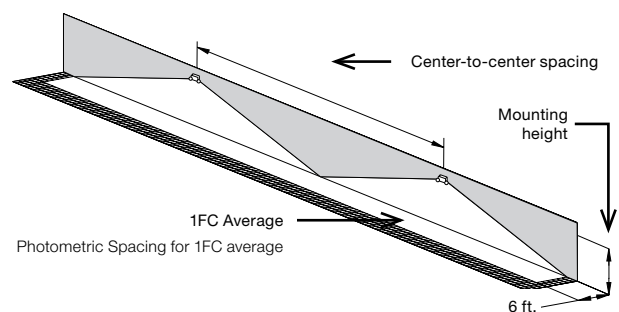

## ELF640 Series

ELF640 vandal resistant



### Description

- ELF640 & ELF640P vandal resistant for indoor use with choice of cast aluminum or plastic back plate
- Include clear polycarbonate UV impact resistant cover

### Lamp type

Choice of MR16 LED lamp voltages and wattages

### Mounting

- Surface Mount
- Universal J-Box mounting

### Approvals

- UL 924 Listed
- Vandal Resistant

**Warranty** (subject to proper installation and maintenance)

Unit: five-year full warranty

Detailed warranty terms located on [page 197](#) or online at: [www.lightalarms.com](http://www.lightalarms.com)



**Dimensions** (Dimensions are approximate and subject to change)

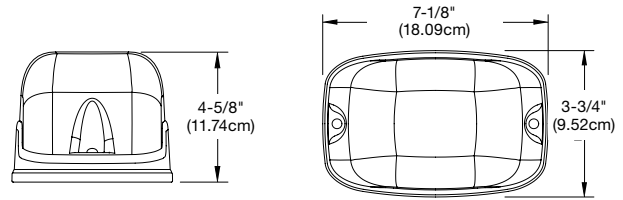

### Photometric performance

Lamp	Spacing center-to-center (feet)	
	7 feet mounting height	15 feet mounting height
LD1	39'	34'
LD2	74'	57'
LD7	49'	39'
LD9	68'	54'
LD10	89'	80'
LD13	51'	39'
LD25	43'	39'

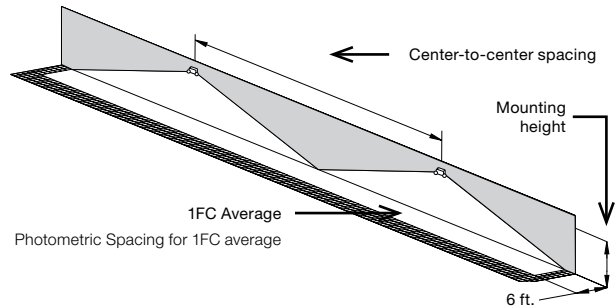

### Lamp selection chart

Lamp suffix	Voltage	Wattage	Lumens	MR 16 LED lamps	
				Replacement #	
LD1	6	4	130	580.0097-L	
LD2	6	5	415	580.0122-L	
LD7	12	4	170	580.0093-L	
LD9	12	5	340	580.0104-L	
LD10	12	6	510	580.0106-L	
LD13	24	4	200	580.0098-L	
LD25	120	4	204	580.0095-L	

### Ordering format

Series	Lamp suffix	Color	Voltage	Options
ELF640P= All polycarbonate single head for dry location	/_____ <sup>1</sup>	-M= White	6= 6 VDC	Blank= no option
ELF640PD= All polycarbonate double head for dry location		-B= Black	12= 12 VDC	T= tamper proof screws
ELF640= Die-Cast back plate single head for dry location		-G= Gray	24= 24 VDC	
ELF640D= Die-Cast back plate double head for dry location			120= 24 VDC/VAC	

**Example:** ELF640D/LD7-M12

<sup>1</sup>Choose from lamp selection chart

## ELF650 Series

ELF650 NEMA-4X & NSF Certified



### Description

- ELF650 and ELF650P NEMA-4X and NSF certified indoor or outdoor use
- ELF650 and ELF650P NEMA-4X and NSF certified with choice of fully gasketed cast aluminum or plastic back plate
- ELF650 and ELF650P NEMA-4X and NSF certified comes standard with Phillips head screws and tamper proof screws
- Include clear polycarbonate UV impact resistant cover

### Lamp type

Choice of MR16 LED lamp voltages and wattages

### Mounting

- Surface mount
- Universal J-Box mounting

### Approvals

- UL 924 listed
- Vandal resistant
- NEMA-4X<sup>1</sup>
- NSF Rated

**Warranty** (subject to proper installation and maintenance)

Unit: five-year full warranty

Detailed warranty terms located on **page 197** or online at: [www.lightalarms.com](http://www.lightalarms.com)

<sup>1</sup>NEMA-4X Certified when installed using a circular NEMA-4X rated junction box (sold separately by Thomas&Betts under P/N 091647-L)



### Ordering format

Series	Lamp suffix	Color	Voltage	Options
ELF650= Die-Cast back plate NEMA-4X and NSF Certified with single head	/ _____ <sup>1</sup>	-M= Mist white	6= 6 VDC	<b>Blank</b> = no option
ELF650D= Die-Cast back plate NEMA-4X and NSF Certified with double head		-B= Black	12= 12 VDC	
ELF650P= All polycarbonate NEMA-4X and NSF Certified with single head <sup>1</sup>		-G= Gray	24= 24 VDC	
ELF650PD= All polycarbonate NEMA 4X and NSF Certified with double head <sup>1</sup>			120= 120 VDC/VAC	

**Example: ELF650/LD9-M12**

**Dimensions** (Dimensions are approximate and subject to change)

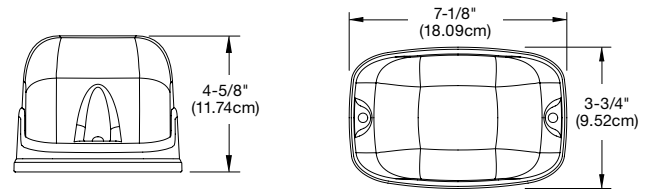

### Photometric performance

Lamp	Spacing center-to-center (feet)	
	7 feet mounting height	15 feet mounting height
LD1	39'	34'
LD2	74'	57'
LD7	49'	39'
LD9	68'	54'
LD10	89'	80'
LD13	51'	39'
LD25	43'	39'

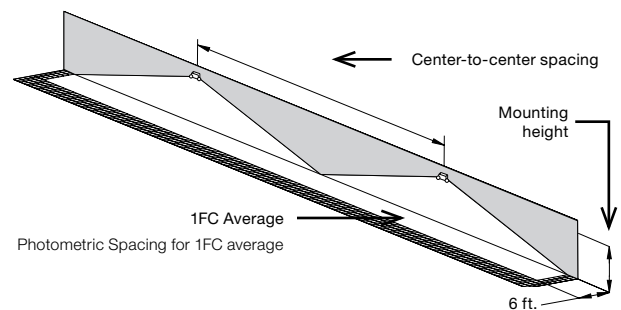

### Lamp selection chart

Lamp suffix	Voltage	Wattage	Lumens	MR 16 LED lamps	
				Replacement #	
LD1	6	4	130	580.0097-L	
LD2	6	5	415	580.0122-L	
LD7	12	4	170	580.0093-L	
LD9	12	5	340	580.0104-L	
LD10	12	6	510	580.0106-L	
LD13	24	4	200	580.0098-L	
LD25	120	4	204	580.0095-L	

<sup>1</sup> Choose from lamp selection chart

## SPRL Series Remote Fixture

NEMA-4X, Severe-performance remote for indoor or outdoor applications



### Housing

- Lightweight polycarbonate gray housing with captive screws
- NEMA-4X rated
- All external fasteners and hardware are constructed of stainless steel
- Die-cast aluminum LED heads

### Mounting

- Simple and easy to install on walls, poles, columns, struts also on vertical
- Pole or column installation bracket sold separately (order catalog number: PMK1-E)
- ½ NPT conduit entry on top or side

### Performance

- 6W, 10W and 15W high efficacy LED emergency heads
- 15W head outperforms traditional 50W MR16 halogen
- Innovative head design: four-LED and dual- driver provide illumination even in case of unexpected component failure

### Approvals

- UL924 Listed
- Can be installed in wide temperature range: -40°F to 131°F (-40°C to 55°C)

**Warranty** (subject to proper installation and maintenance)

Unit: five-year limited warranty

Detailed warranty terms located on [page 197](#) or online at: [www.lightalarms.com](http://www.lightalarms.com)



### Photometry performance

Capable of being installed indoors or outdoors, the SPRL Series LED emergency lights deliver a stable and consistent illumination on the path of egress for a wide range of mounting heights. Depending on the required illumination levels need for the application, choose between three level of lumen output using a 6W, 10W or 15W head.

LED Head	Power	Total lumens	Outperform spacing of MR16 halogen lamp types
L6	6W	565	37W PAR36, MR16 Halogen (700 Lumens)
L10	10W	1000	50W PAR36, MR16 Halogen (950 Lumens)
L15	15W	1300	50W MR16-IR Halogen (1550 Lumens)

### Spacing center-to-center (feet)

Mounting height	Lamp L6/6W, 565Lm	Lamp L10/10W, 1000Lm	Lamp L15/15W, 1300Lm
10 ft	80	110	140
15 ft	70	105	135
20 ft	60	100	130
25 ft	50	95	120

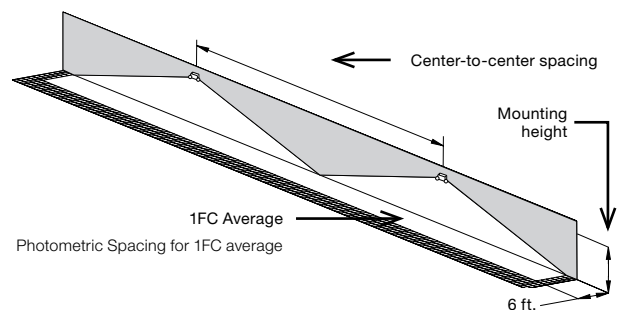

Industrial environment: Wall mounted equipment, reflectances: 10/10/10; 6-ft wide illumination path. Illumination as per NFPA101; Average: 1fc; Min: 0.1fc; Max/min < 40:1

**Dimensions** (Dimensions are approximate and subject to change)

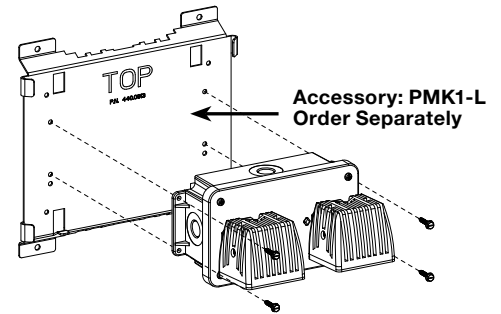
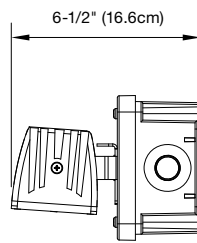
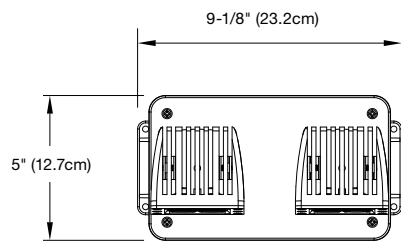

**Warning:** The mounting column must be anchored at both ends: floor and ceiling.

**Ordering format**

Series	Number of heads	LED head
<b>SPRL</b> = Severe performance remote lightweight	<b>Blank</b> = Single head <b>D</b> = Double head	<b>L6</b> = 12-24V – 6W (565 Lumens) <b>L10</b> = 12-24V – 10W (1000 Lumens) <b>L15</b> = 12-24V – 15W (1300 Lumens)

**Example: SPRLDL6**

## Remote Fixture ELF651 Series

Class I division 2, groups A, B, C and D certified remote fixture

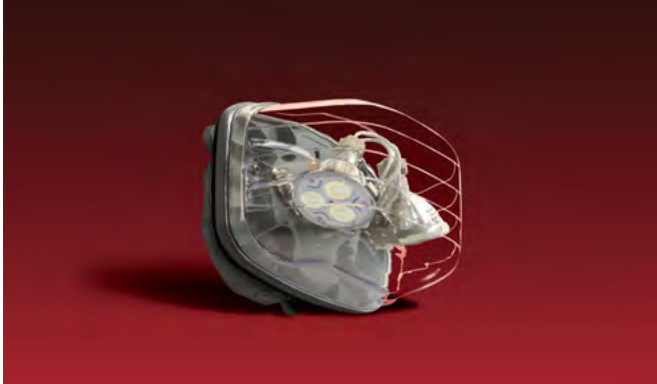

### Description

- Available with single or double lamp heads
- Die-cast aluminum back plate with gasket
- Vandal-resistant UV stabilized polycarbonate lamp cover
- Includes tamper-proof screws and bit
- Universal J-box mounting
- Extreme operational temperature range: -40°F to +104°F (-40°C to +40°C)

### Mounting

- Surface mount
- Conduit entry ½" NPT

### Approval

- CSA-US (To UL 924 standards)
- Evaluated to the UL 844 Standard for Class I Division 2, Groups A, B, C and D

### Warranty (subject to proper installation and maintenance)

Unit: five-year limited warranty

Detailed warranty terms located on [page 197](#) or online at: [www.lightalarms.com](http://www.lightalarms.com)



### Photometry performance

Lamp	Spacing center-to-center (feet)	
	7 feet mounting height	15 feet mounting height
LD1	39'	34'
LD2	74'	57'
LD7	49'	39'
LD9	68'	54'
LD10	89'	80'
LD13	51'	39'
LD26	43'	39'

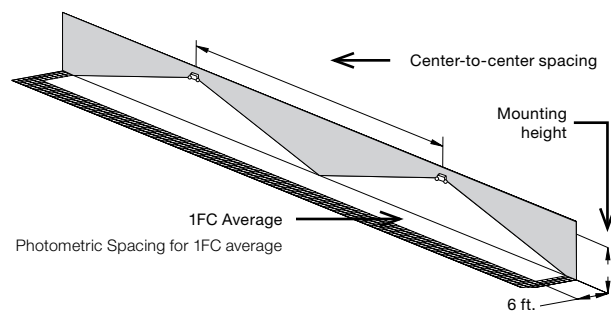

**Dimensions** (Dimensions are approximate and subject to change)

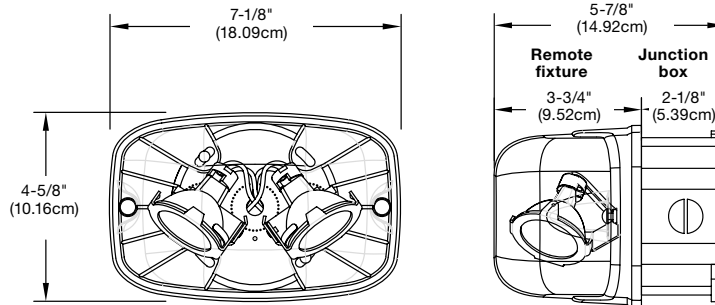

**Lamp selection chart**

MR16 LED lamps						
Lamp suffix	Voltage	Wattage	Lumens	Replacement number	Temperature code	Maximum temperature
LD1	6	4	200	580.0097-L	T4A	248°F/ 120°C
LD2	6	5	415	580.0122-L	T4A	248°F/ 120°C
LD7	12	4	220	580.0093-L	T5	212°F/ 100°C
LD9	12	5	340	580.0104-L	T4A	248°F/ 120°C
LD10	12	6	540	580.0106-L	T4	275°F/ 135°C
LD13	24	4	220	580.0098-L	T5	212°F/ 100°C
LD26	120	4	230	580.0113-L	T4A	248°F/ 120°C

**Ordering format**

Series	Lamp suffix	Color	Voltage
ELF651= Single lamp remote fixture	/ _____ <sup>1</sup>	-G= Gray	6= 6 VDC
ELF651D= Double lamp remote fixture			12= 12 VDC
			24= 24 VDC
			120= 120 VAC/VDC

**Example: ELF651/LD1-G6**

<sup>1</sup> Choose from lamp selection chart

## Remote Fixture EPF401 LED Series

Hazardous location remote fixtures



### Description

- LED Light source
- Indoor use
- Available as a single or double
- Heavy cast aluminum
- Pyrex® lenses

### Finish

- Painted grey

### Mounting

- Surface mount: wall or ceiling
- Pendant mount: single head or double head
- Pendant mount including hazardous location elbows, swivels and conduit extension pipe (6" increments)
- Combination hazardous location junction box/mounting plate
- Conduit entry ½" NPT

### Photometric performance

Lamp	Spacing center-to-center (feet)	
	7 feet mounting height	15 feet mounting height
2 X LD1	43'	29'
2 X LD2	70'	39'
2 X LD7	55'	36'
2 x LD9	67'	41'
2 x LD10	87'	62'
2 X LD13	56'	29'
2 X LD25	58'	39'

### The EXP Family



EXP6N & EXP12N  
battery unit  
PG. 114-115

X402 series  
exit sign unit  
PG. 56-57

EXP6N & EXP12N  
combination series  
PG. 58-59

### Approvals

- CSA US Listed
- Class I, Division 1&2, Groups C and D
- Class II, Division 1&2, Groups E, F and G
- Class III, Division 1&2
- Complies with NEC, OSHA and NEMA for above classes and groups
- Suitable for wet and damp location
- Temperature Code T6

### Warranty (subject to proper installation and maintenance)

Unit: five-year limited warranty

Detailed warranty terms located on [page 197](#) or online at: [www.lightalarms.com](http://www.lightalarms.com)

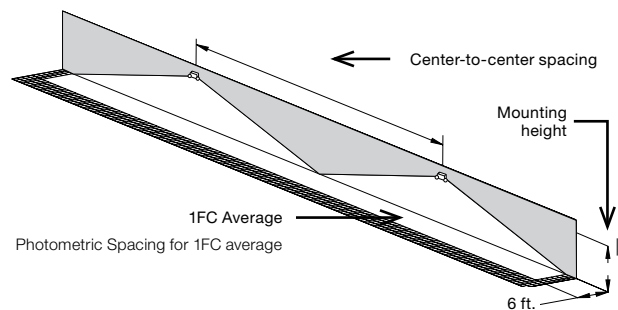



**Dimensions** (Dimensions are approximate and subject to change)

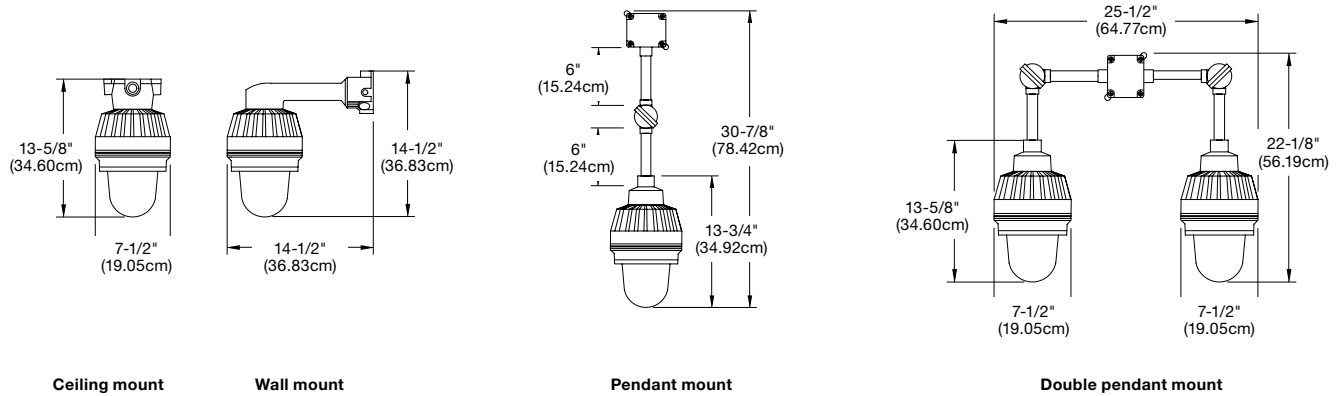

**Options**

Description	Suffix
Guard: One-piece aluminum casting construction. Attaches to globe holder ring with four screws	-GD



**Temperature codes chart**

Lamp suffix	Voltage	Wattage	Temperatures code
LD1	6V	4W	T6
LD2	6V	5W	T6
LD7	12V	4W	T6
LD9	12V	5W	T6
LD10	12V	6W	T6
LD13	24V	4W	T6
LD25	120V	4W	T6

REMOTES & HEADS

**Accessories**

Number	Reflectors/Guards
145.0017-E	-AG= Angle reflector
145.0016-E	-DM= Dome reflector
330.0125-E	-GD= Aluminium guard

**Ordering format**

Series	Mounting	# of lamps	Voltage
EPF401= X-Proof LED Remote Fixture	C= Ceiling Mount P= Pendant Mount W= Wall Mount D= Double Pendant Mount	2 lamps <sup>1</sup>	LD1= 6V-4W, MR16 LED LD2= 6V-5W, MR16 LED LD7= 12V-4W, MR16 LED LD9= 12V-5W, MR16 LED LD10= 12V-6W, MR16 LED LD13= 24V-4W, MR16 LED LD25= 120V-4W, GU10 LED

**Example: EPF401P2LD1**

<sup>1</sup> Each head includes 2 lamps



#### EMERGENCY FLUORESCENT BALLASTS

Self-contained emergency ballasts and LED drivers are available in a range of lumen output capacities to power new or existing fixtures as emergency lighting units. Concealed ballasts do not interfere with the look of existing lighting, and the space-saving design mounts directly on or in a fixture.

# Table of contents

## Battery packs

### LED Emergency drivers



Emergency LED Driver  
**LALDR Series**

148-149



Emergency LED Driver  
**LALDR CEC Series**

150-151

### Emergency battery packs



Introduction  
**About Ballast**

146



Introduction  
**Ballast/ Lamp  
reference chart**

147



Emergency ballast  
**LADL Series**

152



Emergency ballast  
**LADL 4 Pin Series**

153

# About emergency fluorescent ballast packs and AC inverters

## About Emergency Fluorescent Ballast Packs and AC Inverters

Emergency Fluorescent Ballast Packs and AC Inverters are completely self-contained battery-powered systems designed to invert DC battery current to AC current in order to operate AC lighting loads in the event of an emergency. Under normal conditions: AC current flows into the Ballast or Inverter, keeping the DC batteries charged, and AC current continues to power the AC lighting fixture. In an Emergency situation: When AC current stops flowing into the Ballast or Inverter, the Inverter converts DC battery current into AC current to power the AC lighting fixture.

### Lumens and Wattage Capacities

Emergency Fluorescent Ballasts come in various lumen output capacities and are designed to operate only 1 or 2 lamps in a fluorescent fixture type. AC Inverters are based on total wattage capacities and are designed to operate multiple lighting fixtures with different lamp types in an emergency situation.

### Emergency Fluorescent Ballast:

Designed to operate fluorescent lighting loads, these ballasts can be mounted directly on or in the existing fluorescent fixture and are meant to operate one or two lamps within that fixture. Emergency Fluorescent Ballasts are selected based on the lumen output levels needed in an emergency situation and the lamp type being used in the fluorescent fixture during normal AC operation.

### Mini Interruptible Inverter Systems:

These systems are designed to keep incandescent, fluorescent, and LED lighting operating properly when there is a break in power. Available in 32-720W models.

### Single Phase Transfer IPS Systems:

These systems are designed to keep incandescent, fluorescent, and LED lighting operating properly when there is a break in power. The transfer time is 50 milliseconds. Available in single phase from 1500VA to 16700VA.

### Single Phase Fast Transfer Systems (UPS):

These systems are designed to operate in much the same way as the IPS system, but with a transfer time that is sufficient to keep HID lighting on and operate incandescent, fluorescent, and LED lighting loads with no break in power to the critical load upon failure or restoration of the AC power source. Available in single phase from 500VA to 16700VA.

### Three Phase Fast Transfer Systems (UPS):

These fast transfer systems operate on 3 phase 4 wire (120/208VAC or 277/480VAC) utility power. Available for 3 phase applications from 4800VA to 50000VA. The transfer time is sufficient to keep HID lighting on and operate incandescent, fluorescent, and LED lighting loads.



## Ballast / Lamp Quick reference chart

MODEL #	LADL7	LADL12	LADL20-N	LADL30-N	LADL32
Lumens	750	1350	750	3000	500
<b>Lamp Type (# of Lamps)</b>	<b>LINEAR LAMPS</b>				
2'-4' Rapid, Instant, Energy Saving, T8 thru T12 (1)					
2'-4' Rapid, Instant, Energy Saving, T8 thru T12, HO & VHO (2)					
2'-8' Rapid, Instant, Energy Saving, T8 thru T12, HO & VHO (1)					
F15 T8 (1)				+	
F17 T8 (1)				+	+
F17 T8 (2)				+	
F25 T8 (1)					
F25 T8 (2)					
F28 T8 (1)				+	
F32 T8 (1)	+	+		+	+
F32 T8 (2)	+	+		+	
F40 T8 (1)					
FO96 T8 59W (1)				+	
14W T5 (1)	+	+		+	
14W T5 (2)	+	+		+	
21W T5 (1)	+	+		+	
21W T5 (2)	+	+		+	
24W T5 (1)	+	+			
28W T5 (1)	+	+		+	+
28W T5 (2)	+	+		+	+
39W T5 (1)	+	+		+	
54W T5 HO (1)	+	+		+	
54W T5 HO (2)	+			+	
F20 T12 (1)				+	+
F20 T12 (2)				+	
F40 T12 (1)				+	+
F40 T12 (2)				+	
F48 T12 (1)					
F96 T12 60W (1)					
<b>Lamp Type (# of Lamps)</b>	<b>COMPACT LAMPS – BIAx LAMPS</b>				
18W Long Compact (1)			+	+	
18W Long Compact (2)			+	+	
24W Long Compact (1)			+	+	
24W Long Compact (2)			+	+	
36W Long Compact (1)	+	+	+	+	
36W Long Compact (2)	+	+	+	+	
40W Long Compact (1)	+	+		+	+
40W Long Compact (2)		+		+	
50W Long Compact (1)	+	+		+	
50W Long Compact (2)	+	+		+	
55W Long Compact (1)				+	
7W PL CF 2-Pin (1)					
9W PL CF 2-Pin (1)					
13W PL CF 2-Pin (1)					
18W PL CF 2-Pin (1)					
26W PL CF 2-Pin (1)					
13W PL CF 4-Pin (1)			+	+	
13W PL CF 4-Pin (2)			+	+	
18W PL CF 4-Pin (1)			+	+	
18W PL CF 4-Pin (2)			+	+	
26W PL CF 4-Pin (1)			+	+	
26W PL CF 4-Pin (2)			+	+	
32W PL CF 4-Pin (1)	+	+	+	+	
32W PL CF 4-Pin (2)	+	+	+	+	
42W PL CF 4-Pin (1)			+	+	
42W PL CF 4-Pin (2)				+	
57W PL CF 4-Pin (1)					
57W PL CF 4-Pin (2)					
70W PL CF 4-Pin (1)					
20W Circline (1)					
22W Circline T9 (1)					
22W Circline T5 (1)					
40W Circline T8 (1)					
40W Circline T5 (1)					
55W Circline T5 (1)					
F28 2D (1)					
F28 2D (2)					
F38 2D (1)					
F38 2D (2)					

## LALDR Series

Convert new or existing LED fixtures into emergency lighting units with a constant power emergency LED driver



### Housing

- High impact thermoplastic enclosure, 5VA flame retardant in black finish
- LED illuminated remote test switch

### Mounting

- Suitable for installation on top or remotely (up to 50 feet)

### Lamp type operation

- LED lamps with 20VDC to 50VDC operating voltage
- Can be wired for normally-on, normally off or switched loads
- Lumen output depends on LED light source efficacy (Lumens/watts)

### Lumen output

- Universal 120/277, 50/60Hz input
- Provides 90 minutes of emergency operation
- Surge protection
- Output classification: Class 2 compliant
- Output and input overcurrent protection
- Constant power supply in emergency mode

### Battery

- Long-life maintenance free rechargeable Nickel-Cadmium battery

### Approvals

- Damp location listed 32°F to 122°F (0°C to 50°C)
- UL classified for field or factory installation
- UL924 approved
- NFPA 101 life safety code, NEC, and OSHA

### Warranty (subject to proper installation and maintenance)

Ballast: five-year full warranty

Detailed warranty terms located on [page 197](#) or online at: [www.lightalarms.com](http://www.lightalarms.com)



## Important note

### LEDDR SERIES System Coordination Guidelines

These guidelines were developed to allow the lighting system Designer/Specifier to predict the operating performance levels of LED luminaires when powered by an electrically compatible LEDDR Series model. It is ultimately the responsibility of the Designer/Specifier to ensure that the as installed system delivers code-compliant path of egress illumination.

#### 1. Determine Electrical Compatibility

- Verify that the Luminaire LED Driver, where applicable, is Class 2 compliant.
- Verify that the Luminaire LED Lamp(s) have an operating voltage between 20Vdc and 50Vdc.
- Verify that the Luminaire LED Lamp(s) have a power rating equal to, or greater than, the emergency power rating of the LEDDR model under consideration.

**Calculate lumen output during emergency operation**

- Lumen output = Efficacy (Lumen/watt) X Emergency LED Driver wattage
- In order to understand luminaire efficacy:
  - Access luminaire data by logging onto Design Lites Consortium:  
**www.designlights.org**
  - Select ‘Search the DLC Qualified Product List’ on the DLC homepage
  - Enter manufacturer name and P/N of luminaire under consideration in the ‘search by keyword’ text window
  - Select ‘Search’ tab to open the ‘Qualified Products List’
  - Determine luminaire Lumens per Watt efficacy in ‘Rated Data’ specifications
  - Multiply luminaire Lumens per Watt by Emergency Output of the ‘LED Driver’ model under consideration

**Dimensions** (Dimensions are approximate and subject to change)

Model	Length	Width	Height
LALDR-5	11.46"	2.63"	1.48"
LALDR-7	15.35"	2.63"	1.48"
LALDR-11	15.35"	2.63"	1.48"
LALDR-14	19.19"	2.63"	1.48"
LALDR-17	19.19"	2.63"	1.48"

**Electrical information**

Model	Output	Input
LALDR-5	5 Watts	3.9 Watts
LALDR-7	7 Watts	4.8 Watts
LALDR-11	11 Watts	5.7 Watts
LALDR-14	14 Watts	6.9 Watts
LALDR-17	17 Watts	7.9 Watts

**Ordering format**

Series	Wattage
LALDR-	5
	7
	11
	14
	17

**Example: LALDR-5**

## LALDR CEC Series Emergency LED driver

Convert new or existing LED fixtures into emergency lighting units with constant power emergency LED drivers



### Housing

- 20 gauge steel housing, red powder coated finish
- LED illuminated remote test switch

### Mounting

- Suitable for installation on top or remotely (up to 50 feet)

### Lamp types

- LED lamps with 10VDC to 60VDC operating voltage
- Can be wired for normally-on, normally off or switched loads
- Lumen output depends on LED light source efficacy (lumens/watts)

### Electronics

- Universal 120/277, 50/60Hz input
- Provides 90 minutes of emergency operation
- Surge protection
- Output and input overcurrent protection
- Constant power supply in emergency mode

### Battery

- Long-life, lithium battery
- 24 hour battery recharge time

### Approvals

- Damp location listed
- UL classified for field 50F to 122F
- UL 924 approved, NFPA 101 life safety code, NEC, and BC-California Energy Commission Title 20

**Warranty** (subject to proper installation and maintenance)

Unit has a three-year warranty

Detailed warranty terms located online at:

[www.lightalarms.com](http://www.lightalarms.com)

See sample: [http://www.lightalarms.com/modules/Files/la\\_434c\\_RecArch\\_LA\\_Battery\\_Approved\\_25-10-2020.pdf](http://www.lightalarms.com/modules/Files/la_434c_RecArch_LA_Battery_Approved_25-10-2020.pdf)



## Important note

### LEDDR SERIES System Coordination Guidelines

These guidelines were developed to allow the lighting system Designer/Specifier to predict the operating performance levels of LED luminaires when powered by an electrically compatible LEDDR Series model. It is ultimately the responsibility of the Designer/Specifier to ensure that the as installed system delivers code-compliant path of egress illumination.

#### 1. Determine Electrical Compatibility

- Verify that the Luminaire LED Driver, where applicable, is Class 2 compliant.
- Verify that the Luminaire LED Lamp(s) have an operating voltage between 10Vdc and 60Vdc.
- Verify that the Luminaire LED Lamp(s) have a power rating equal to, or greater than, the emergency power rating of the LEDDR model under consideration.



**Calculate lumen output during emergency operation**

- Lumen output = Efficacy (lumen/watt) X emergency LED driver wattage
- In order to understand luminaire efficacy:
  - Access luminaire data by logging onto DesignLites Consortium [www.designlights.org](http://www.designlights.org)
  - Select 'Search the DLC Qualified Product List' on the DLC homepage
  - Enter manufacturer name and P/N of luminaire under consideration in the 'search by keyword' text window
  - Select 'Search' tab to open the 'Qualified Products List'
  - Determine luminaire lumens per watt efficacy in 'Rated Data' specifications
  - Multiply luminaire lumens per watt by emergency output of the 'LED Driver' model under consideration

**Dimensions** (dimensions are approximate and subject to change)

11.024" x 2.543" x 1.8" (L x W x H)

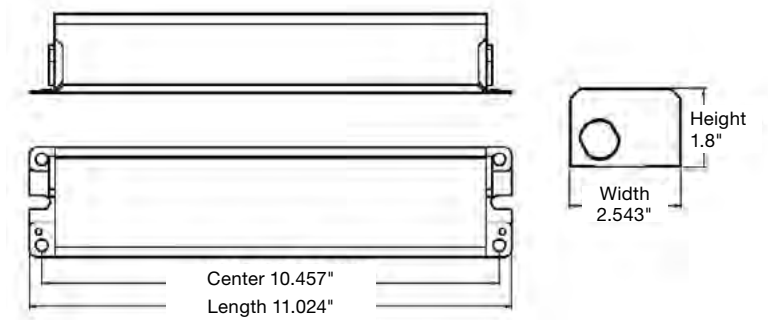

**Electrical information**

Model	Output	Input
LALDR-7-CEC	7 Watts	5 Watts
LALDR-12-CEC	12 Watts	7 Watts

**How to order**

Series	Wattage	Approval
LALDR-	7 12	-CEC= CEC Title 20 for California
<b>Example: LALDR-7-CEC</b>		

## LADL Linear Emergency Fluorescent Battery pack

Convert new or existing fluorescent fixtures into emergency lighting units  
emergency ballast



### Housing

- Low profile steel housing contains, battery, battery charger, transfer circuit and high frequency inverter
- Optional end caps available
- Operating temperature 68°F to 122°F (20°C to 50°C)

### Mounting

- Internal or external mounting to a fluorescent fixture

### Lamp type operation

- Refer to ballast/Lamp reference chart for specific lamp type page 147

### Electronics

- Can be wired to operate switched, un-switched or normally off fixtures without affecting normal operation
- Will cold start and illuminate lamps
- Dual voltage 120/277VAC, 2.5W

### Controls

- Momentary test switch allows for quick operational check of entire system

**Dimensions** (Dimensions are approximate and subject to change)

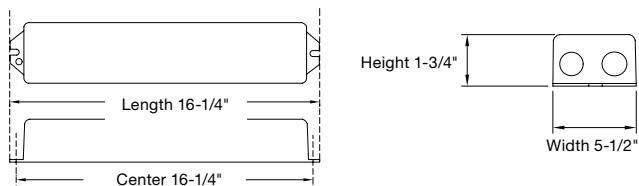

### Sealed maintenance-free battery

- Nickel-Cadmium battery
- Provides 90 minutes of emergency operation

### Approvals

- UL 924 Listed Damp location I (50°F to 104°F)
- Damp location listed

**Warranty** (subject to proper installation and maintenance)

Ballast: five-year full warranty

Detailed warranty terms located on [page 197](#) or online at: [www.lightalarms.com](http://www.lightalarms.com)

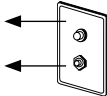

**Accessories** (order as a separate item)

Description	Suffix
 External mounting kit includes wire bundle cover	071139-E
Remote test switch (Metal faceplate)	RTS
Remote test switch (Plastic faceplate)	RTS-1
Recommended for inaccessible locations. Test switch and charging indicator on a single mounting plate.	
Replacement Test Switch	TBTSP-E

### Ordering information

#### Series

LADL32  
LADL7  
LADL12  
LADL30-N

**Example: LADL32**

## LADL 4 Pin Series

Convert new or existing fluorescent fixtures into emergency lighting units  
750 lumen emergency ballast



### Housing

- Steel housing contains, battery, battery charger, transfer circuit and high frequency inverter
- Operating temperature 32°F to 122°F(0°C to 50°C)

### Mounting

- Internal or external mounting to a fluorescent fixture

### Lamp type operation

- Refer to ballast/Lamp reference chart for specific lamp type page 147

### Lumen output

- (1) Lamp 350-750 lumens
- (2) Lamps 425-750 lumens

### Electronics

- Can be wired to operate switched, un-switched or normally off fixtures without affecting normal operation
- Will cold start and illuminate lamps
- High capacity, automatic, dust-tight instantaneous transfer relay
- Low voltage disconnect prevents over discharge of battery
- Automatic brownout protection
- Battery connector prevents battery discharge during installation

### Dimensions (Dimensions are approximate and subject to change)

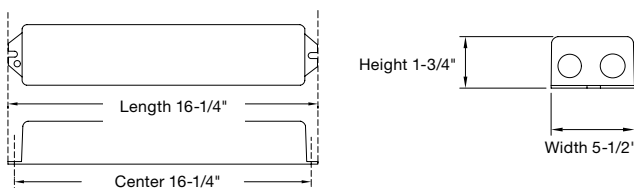

### Controls

- Red charger monitor LED indicates charging of the battery and AC present
- Momentary test switch allows for quick operational check of entire system

### Sealed maintenance-free battery

- Nickel-Cadmium battery
- Provides 90 minutes of emergency operation

### Power requirements

- Dual voltage 120/277VAC, 60Hz, 1.8W

### Approvals

- UL 924 Standards
- Damp location listed

### Warranty (subject to proper installation and maintenance)

Ballast: five-year full warranty

Detailed warranty terms located on page 197 or online at: [www.lightalarms.com](http://www.lightalarms.com)



### Accessories (order as a separate item)

Description	Suffix
Remote test switch (Metal faceplate)	RTS
Remote test switch (Plastic faceplate)	RTS-1
Replacement Test Switch	TBTSP-E

### Ordering information

Series
LADL20-N

Example: LADL20-N

















#### CENTRAL & INVERTER SYSTEMS

Designed to meet the unique needs of emergency lighting loads, inverters provide power to existing lighting to function as emergency lighting when main power fails. By providing a single point of testing, inverters minimize maintenance requirements. Compact Mini Inverters are ideal for LED, incandescent, and fluorescent lighting, and are available in up to 1000W models. Interruptible Power Systems (IPS) and Uninterruptible Power Systems (UPS) provide higher capacity units for industrial applications.

# Table of contents

## Central & Inverter Systems

					
<b>EPC Fixture Mounted Series</b>	<b>EPC 2 Series</b>	<b>Mini Inverter Check List</b>	<b>Inverter System Low Capacity Mini Inverter Series</b>	<b>Inverter System 125W-720W Mini Inverter Series</b>	<b>Inverter System 1000W Mini Inverter Series</b>
156-157	158-159	161	162-163	164-165	166-167
					
<b>Features &amp; Benefits Light Support Power Inverter Systems</b>	<b>Central System Light Support Power Systems Compact Series</b>	<b>Central System Light Support Power Systems IPS Single Phase Series</b>	<b>Central System FTC Single Phase Series</b>	<b>Central System Light Support Power Systems 3FTC Three Phase Series</b>	<b>Central System Light Support Power Systems FTC3R &amp; 3FTC3R</b>
168-169	170-171	172-173	174-175	176-177	178-179
					
<b>Product sector Control Panel &amp; Display Functions</b>	<b>Data Light Support Power Systems Options - AC Central Systems Request Data</b>				
180	181				

## EPC Fixture Mounted Series

Emergency power control for generator and mini inverters. Supplies power to switched lighting fixtures.



### Mechanical specifications

- UL94-5VA rating
- Shipping weight: 8 oz
- Damp location
- Temperature: 32°F - 140°F (0°C - 60°C)
- Color: Black
- Body size: 4.9" x 0.9" x 1.2"

### Emergency Operation

- The EPC-2-FM-L & EPC-2-FM-D-L will operate any lamp type in the designated fixture for the duration of the generator or mini inverter supply

### Initial illumination

- The EPC-2-FM-L & EPC-2-FM-D-L will operate the designated lamp at full light output

### Approval

- UL924 Listed

### Wiring diagrams

- Visit our website: [lightalarms.com](http://lightalarms.com)

### Mounting

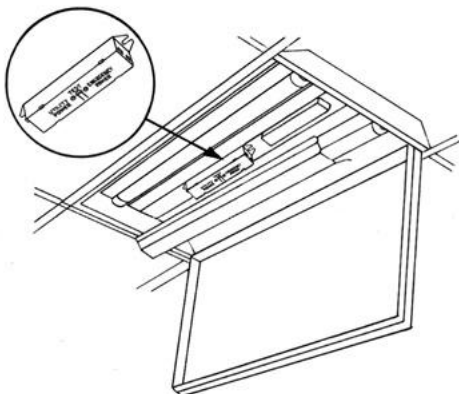

### Housing

- Thermoplastic UL94-5VA suitable for plenum installations
- Compatible with LED, fluorescent and incandescent lamp types including standard, energy-saving, and electronic AC drivers and ballasts<sup>1</sup>

### Mounting

- Wall and ceiling mount

### Options

- 0-10V Dimming standard on the EPC-FM-2-D-L model
- Advanced Diagnostics standard EPC-2-FM-L and EPC-2-FM-D-L

### Lamp types

- Filed selectable fire alarm, remote test option
- During utility power interruption, automatically connects generator or inverter circuit to emergency fixture and bypasses switching control to full light output for duration of inverter or generator supply

### Lumen output

- Allows switching control of emergency fixtures during normal operation
- Allows auxiliary generator power on a switched lighting fixture

### Power requirements

- Dual voltage 120/277V 60Hz

### Approvals

- Meets or exceeds all National Electrical Code and Life Safety Code Emergency Lighting Requirements

### Warranty (subject to proper installation and maintenance)

Unit has a five-year warranty

Detailed warranty terms located on [page 197](#) or online at: [www.lightalarms.com](http://www.lightalarms.com)

<sup>1</sup> When using EPC-FM-2-L & EPC-FM-2-D-L to control more than 10 emergency ballasts with a high corrective power factor capacitor, consult factory for more information regarding inrush currents.



UL924 LISTED

### Ordering information

#### Series

**EPC-2-FM-L**= Emergency transfer switch fixture mounted with Advanced Diagnostics

**EPC-2-FM-D-L**= Emergency transfer switch fixture mounted with Advanced Diagnostics and 0-10 dimming

**Example: EPC-2-FM-D-L**

Single line drawing

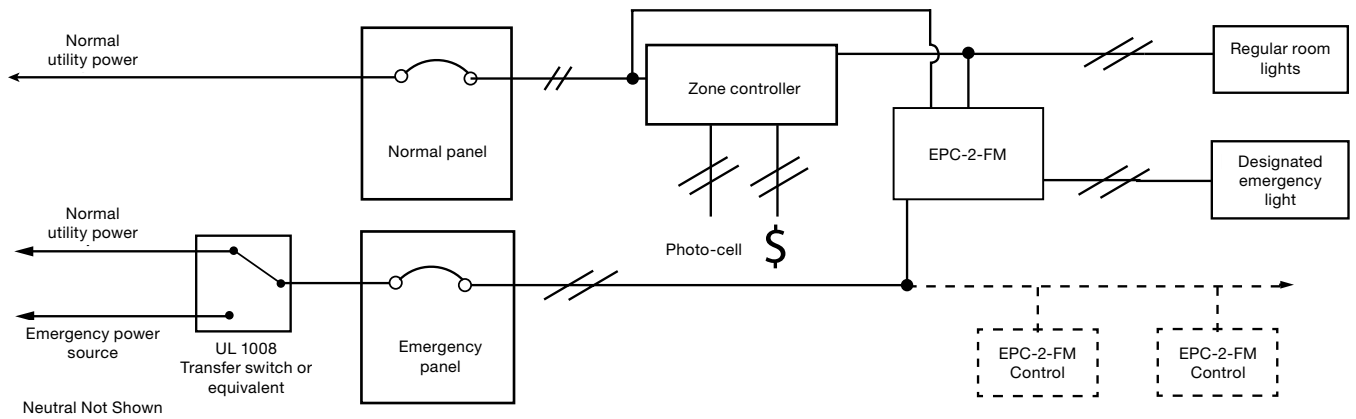

Wiring diagram

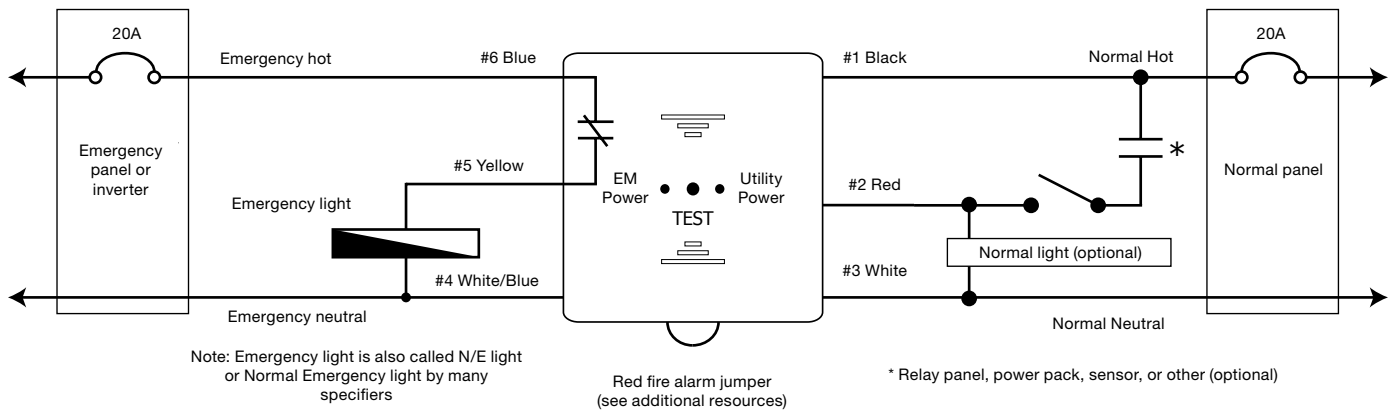

Specifications

Electrical	
Model number	EPC-2-FM
Sensing input	120V-277V
LED load rating	3A (120-277V)
Ballast load rating	5A (120-277V)
Incandescent load	360W (120V)/600W (277V)
Warranty	Five-year replacement warranty

Mechanical	
Mounting	Fixture mount, panel mount
Rating	UL94-5VA, Damp location rated
Shipping weight/Color	8 oz./Black
Temperature	32°F - 32°F (0°C - 60°C)
-	-
Body size	125mm X 25.4 mm X 30mm (L X H X W)

NOTE

When using EPC in conjunction with Lightalarms Mini-Inverter, the inverter must be non self-test/self diagnostics model.

## EPC 2 Series

Emergency power control for generator and mini inverters.

Supplies power to switched lighting fixtures.



### Mechanical specifications

- Mounts in 4-11/16" Junction box with single gang plaster ring
- UL94-5VA rating
- Shipping weight: 12oz
- Temperature: 32°F - 140°F (0°C - 60°C)
- Color: White
- Flush mounted single gang
- Body size: 3" x .7" x 1.2"

### Emergency Operation

- The EPC-2-L & EPC-2-D-L will operate any lamp type in the designated fixture for the duration of the generator or mini inverter supply

### Initial illumination

- The EPC-2-L & EPC-2-D-L will operate the designated lamp at full light output

### Approval

- UL924 Listed

### Wiring diagrams

- Visit our website: [lightalarms.com](http://lightalarms.com)

### Mounting

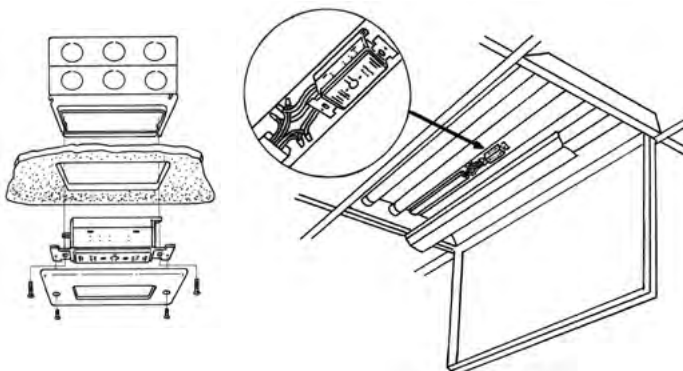

### Housing

- Compatible with LED, fluorescent and incandescent lamp types including standard, energy-saving, and electronic AC drivers and ballasts<sup>1</sup>

### Mounting

- Wall or ceiling mount

### Options

- 0-10V Dimming standard on the EPC-2-D-L model
- Advanced Diagnostics standard EPC-2-L and EPC-2-D-L

### Lamp types

- During utility power interruption, automatically connects generator or inverter circuit to emergency fixture and bypasses switching control to full light output for duration of inverter or generator supply

### Lumen output

- Allows switching control of emergency fixtures during normal operation
- Allows auxiliary generator power on a switched lighting fixture

### Power requirements

- Dual voltage 120/277V 60Hz

### Approvals

- Meets or exceeds all National Electrical Code and Life Safety Code Emergency Lighting Requirements

### Warranty (subject to proper installation and maintenance)

Unit has a five-year warranty

Detailed warranty terms located on [page 197](#) or online at: [www.lightalarms.com](http://www.lightalarms.com)

<sup>1</sup> When using EPC-2-L & EPC-2-D-L to control more than 10 emergency ballasts with a high corrective power factor capacitor, consult factory for more information regarding inrush currents.



UL924 LISTED

### Ordering information

#### Series

**EPC-2-L**= Emergency transfer switch

**EPC-2-D-L**= Emergency transfer switch with Advanced Diagnostics and 0-10 dimming

**Example: EPC-2-D-L**



**Single line drawing**

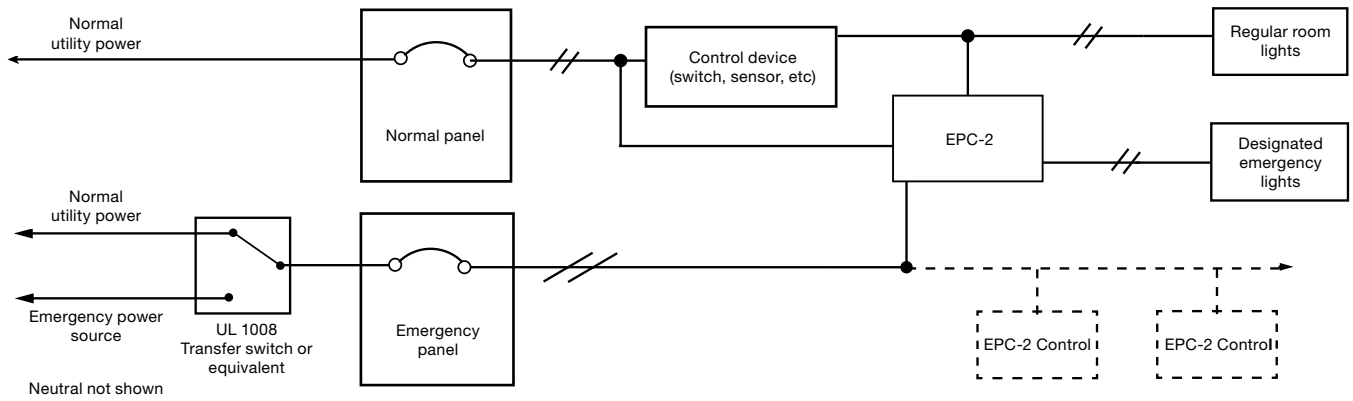

**Wiring diagram**

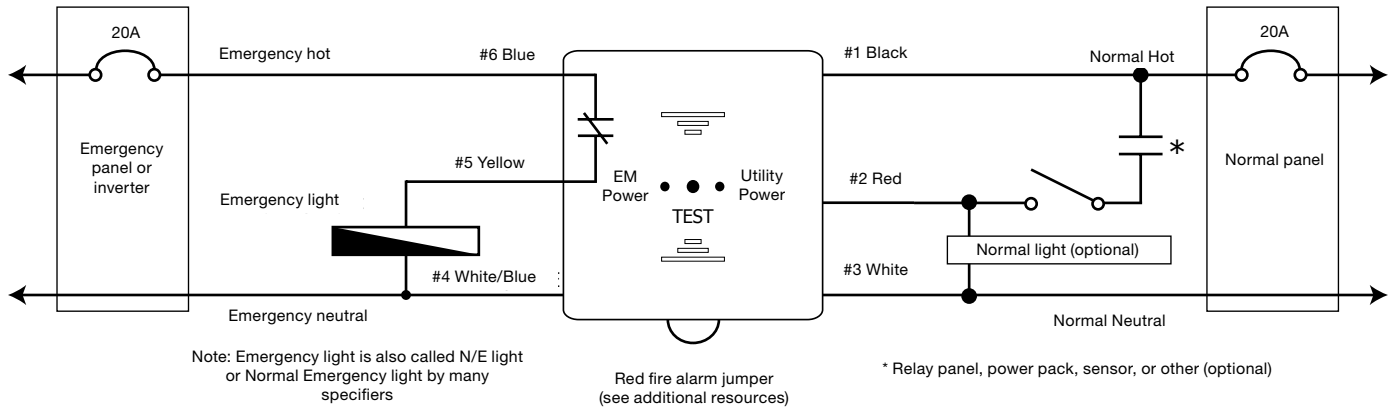

**Specifications**

Electrical	
Model number	EPC-2
Sensing input	120V-277V
LED load rating	120V-277V (20A)
Ballast load rating	20A (120-277V)
Incandescent load	1200W (120V)/1500W (277V)
Warranty	Five-year replacement warranty

Mechanical	
Mounting	4-11/16" Junction box with single gang plaster
Rating	UL94-5VA
Shipping weight/Color	12 oz. / White
Temperature	32°F - 140°F (0°C - 60°C)
Flush mounted size	Single gang size
Body size	1.7" X 3" X 1.2" (W X H X D body)

**NOTE**

When using EPC in conjunction with Lightalarms Mini-Inverter, the inverter must be non self-test/self diagnostics model.



## Mini Inverter Series - Compatibility checklist

### 1) Input voltage

120VAC  277VAC

### 2) Output voltage

120VAC  277VAC

### 3) Type of load

EXIT  LED  LED Highbay  Incandescent  Fluorescent (HID non compatible)

#### Compatible Exit Signs

Genesis GX  
Grande  
Galaxy XD  
XV  
XVHZ  
Simplicity Universal  
QLX  
Chicago Edge-Lit

LED load specifications: \_\_\_\_\_

Total watts: \_\_\_\_\_

Power factor: \_\_\_\_\_

Input current: \_\_\_\_\_

Inrush current: \_\_\_\_\_

Inrush length: \_\_\_\_\_

### 4) mode of Operation

Normally ON  Normally OFF  Switched loads  Mixed

### 5) Options (refer to available options for each type system)

Diagnostics audible       Diagnostics non audible  
 No diagnostics       Nexus wired  
 Nexus Wireless       Time delay  
 Load shedding       Service alarm contact

## Low Capacity Mini Inverter Series

Interruptible unit equipment 32W or 55W



### Construction

- Heavy-duty steel cabinet
- White baked on powder paint coating provides scratch and corrosion resistance

### Mounting

- Surface mount
- Recessed T-bar (plenum rated)

### Lamp types operated

- LED
- Incandescent
- Fluorescent
- Operates switched, normally-on or normally-off fixture types, incandescent
- LED, fluorescent and ballast combinations, including triac dimmable ballasts<sup>1</sup>

### Load capacity

- 32W & 55W
- Allows for remote mounting of the emergency fixtures at distances of up to 1000 feet
- May accept load when load feature power factor range from 0.44 lead to 0.44 lag

### Electronics

- Pure sine wave inverter
- Temperature compensated charger
- Low battery voltage disconnect
- Unit comes standard with electronic lockout and brownout circuits

### Controls

- Control panel with momentary test switch, AC-On, Charger-On and
- Inverter-On LED indicators
- Sealed maintenance-free battery
- 12V oversized valve regulated lead-calcium (VRLA) battery
- Provides 90 minutes of emergency operation

### Power requirements

- Choice of voltage: 120V in/120V out or 277V in/277V out operation, 60Hz

### Approvals

- UL 924 Standard
- Meets or exceeds all National Electric Codes and Life Safety Code
- Emergency lighting requirements

### Warranty (subject to proper installation and maintenance)

- Unit has a three year full warranty
- Battery has a three-year full, plus an additional three year pro-rata warranty

Detailed warranty terms located on **page 197** or **online at: [www.lightalarms.com](http://www.lightalarms.com)**



<sup>1</sup> When using hi-bay fixtures or screw-in type LED lamps, consult the factory.

**Specifications**

Transfer time	Voltage regulation on emergency	Frequency regulation on emergency	Load power factor range	Operating temperature
Less than 1 second	+/- 5%	60 Hz +/- 0.5%	0.44 lead to 0.44 lag	68° to 86°F (20° to 30°C)

**Electrical characteristics and dimensions**

System type	Power rating	Sine wave	Installation	Cabinet dimensions			Number of battery	Weight
				W"	H"	D"		120V & 277V
LMILC32-S	32W/VA	Pure	Surface mount	14-3/4"	6-7/8"	3-1/8"	1	14 lbs
LMILC32-T	32W/VA	Pure	Recessed T-bar	23-7/8"	6-1/4"	4"	1	15 lbs
LMILC55-S	55W/VA	Pure	Surface mount	14-3/4"	6-7/8"	4-3/8"	1	18 lbs
LMILC55-T	55W/VA	Pure	Recessed T-bar	23-7/8"	6-1/4"	4"	1	19 lbs

Note: For wiring diagram, please refer to instruction sheets.

**Power consumption and unit rating**

Model number	Input rating	Emergency power available for load (90min)
LMILC32	41W/VA	32W
LMILC55	64W/VA	55W

**Ordering format**

Series	Capacity	Voltage in/out	Battery type	Mounting
<b>LMILC</b>	<b>32</b> = 32W/VA <b>55</b> = 55W/VA	<b>Blank</b> = 120/277VAC	<b>Blank</b> = Lead-Calcium	<b>-S</b> = Surface mount housing <b>-T</b> = Plenum rated ceiling T-grid mount housing

**Example: LMILC32-S**

## Mini Inverter Series

Interruptible unit equipment standard with non-audible improved self-diagnostics circuitry



### Construction

- 14-gauge steel
- White semi-gloss powered-coat paint finish

### Mounting

- Surface mount
- Optional recessed T-bar (125W unit only)

### Lamp types operated

- LED
- Incandescent
- Fluorescent
- Operates switched, normally-on or normally-off fixture types, incandescent
- Incandescent, LED, fluorescent lamps and ballast combinations, including triac dimmable ballasts (consult factory if DALI dimming)<sup>1</sup>

### Load capacity

- 125W, 250W, 400W or 720W
- Line voltage allows for remote mounting of the emergency fixtures at distances up to 1000 feet
- May accept load to it's full capacity when load feature power factor of 0.9 for 250W model and 0.8 for 125, 400 and 720W model

### Electronics

- High-efficiency pure sine wave inverter at 250W capacity or higher
- Temperature compensated charger
- Replaceable output fuse protection
- Low battery voltage disconnect
- Unit comes standard with electronic lockout and brownout circuits

### Controls

- Standard with a non-audible self diagnostic/charger is fully self-contained, fully automatic microcontrollerbased system
- Optional audible auto diagnostic available
- Standard lighting control override for 0-10V dimming systems

### Load Shedding – Available on LMIU-250 models only

- During a power outage the emergency fixture is dimmed to 25% or 45% brightness output. Reducing wattage draw from the fixture will allow for more fixture to be connected to the Mini Inverter.
- Maximum 20 Emergency fixtures can be daisy chained per LMIU-250
- In standby mode, the maximum normally-on load that can be connected to LMIU-250-LD is 960 watts

### Nexus® Option

- Units equipped with Nexus® self-testing monitoring system circuitry shall selftest, in accordance with NFPA101, Life Safety Code minimum 30 seconds every 30 days, 30 minutes every six months and 90 minutes annually as well as keep a history of all testing logs, plus feature a real-time diagnoses, as well as, be able to locate exact fixture location while notifying service personnel to the status of the fixture via email notification. Nexus® system interface with an improved minimum load lost detection of 10%

### Sealed maintenance-free battery

- 12V oversized valve regulated lead-calcium (VRLA) battery
- Provides 90 minutes of emergency operation

### Power requirements

- Choice of voltage 120V in/120V out or 277V in/277V out operation, 60Hz

### Approvals

- UL 924 Standard
- Meets or exceeds all National Electric Code and Life Safety Code Emergency Lighting Requirements
- BC – California Energy Commission Title 20

### Warranty (subject to proper installation and maintenance)

- Battery has a 3-year full, plus 7-year pro-rata warranty
- Unit has a three-year warranty

Detailed warranty terms located on **page 197** or online at: [www.lightalarms.com](http://www.lightalarms.com)



<sup>1</sup> When using hi-bay fixtures or screw-in type LED lamps, consult the factory.

## Replacement battery

Series	Part number
LMIU-125	860.0024-L
LMIU-250	2X 860.0024-L
LMIU-400	2X 860.0043-L
LMIU-720	2X 860.0096-L

## Specifications

Transfer time	Voltage regulation on emergency	Frequency regulation on emergency	Load power factor range	Operating temperature
Less than 1 second	+/- 3%	60 Hz +/- 1%	250W model: 0.9 leading to 0.9 lagging	68°F to 86°F (20° to 30°C)
-	-	-	125, 400 & 720W models: 0.8 leading to 0.8 lagging	-

## Electrical characteristics and dimensions

Power rating	Sine wave	Installation	Cabinet dimensions			Number of battery	Weight	Weight w/o battery
			W"	H"	D"		120V & 277V	120V & 277V
125W	Modified	T-Bar	24"	6.5"	8"	1	43 lbs	20 lbs
125W	Modified	Wall	23"	12.2"	7.3"	1	41 lbs	18.5 lbs
250W	Pure	Wall	27"	12.2"	7.3"	2	76 lbs	30 lbs
400W	Pure	Wall	24"	20"	10.5"	2	128 lbs	50 lbs
720W	Pure	Wall	24"	20"	14.5"	2	185 lbs	72 lbs

Note: For wiring diagram, please refer to instruction sheets.

## Power consumption and unit rating - Non-CEC models

Model number	Ac specs	Emergency power available for load			
		90 minutes	2H	3H	4H
LMIU-720	120 / 277VAC 6.90 / 4.00 Amps	720W	480W	360W	270W

## Power consumption and unit rating - CEC models

Model number	Ac specs	Emergency power available for load				
		AC power stand by	90 minutes	2H	3H	4H
LMIU-125	120 / 277VAC 1.15 / 0.50 Amps	1.44W	125W	83W	62W	47W
LMIU-250	120 / 277VAC 2.28 / 0.99 Amps	2.26W	250W	167W	125W	94W
LMIU-400	120 / 277VAC 3.73 / 1.62 Amps	3.21W	400W	300W	200W	150W

## Ordering format

Series	Capacity	Voltage in/out	Diagnostic feature	Options	Approval
<b>LMIU</b>	-125= 125W -250= 250W -400= 400W -720= 720W	<b>Blank</b> = 120/120VAC or 277/277VAC	<b>Blank</b> = Includes improved self-diagnostics (non-audible) <sup>1</sup> <b>-ID</b> = Improved self-diagnostics (audible) <sup>1</sup> <b>-NID</b> = No self-test/Self-diagnostic <b>-NEX</b> = Nexus® wired <b>-NEXRF</b> = Nexus® wireless	<b>-D3</b> = Time delay (15 minutes) <b>-LDC25</b> = Load shedding to 25% brightness <sup>2</sup> <b>-LDC45</b> = Load shedding to 45% brightness <sup>2</sup> <b>-SAC</b> = Service alarm contact <sup>3</sup> <b>-T</b> = Recessed T-Bar mounting (125W unit only)	<b>-CEC</b> = CEC Title 20 for California <sup>4</sup>

**Example: LMIU-720**

<sup>1</sup> Minimum load required: 10% of unit capacity

<sup>2</sup> Available on 250W models only

<sup>3</sup> Service alarm contact (SAC) shall provide a 24V signal, the charger board will indicate a fault by choosing a contact.

<sup>4</sup> Available with 125, 250 and 400W capacities only

## 1000W Capacity Mini Inverter Series

Interruptible unit equipment standard with non-audible improved self-diagnostics circuitry



### Housing

- 14-Gauge Steel
- White semi-gloss powdered-coat paint finish

### Mounting

- Surface mount

### Compatible loads

- LED
- Incandescent
- Fluorescent
- Operating switched, normally-on or normally-off fixture types
- Triac dimming
- 0-10V Dimming
- DALI dimming - consult factory

### Load capacity

- 1000W
- Line voltage allows for remote mounting of the emergency fixtures at distances up to 1000 feet

### Electronics

- High-efficiency pure sine wave inverter
- Temperature compensated charger
- Replaceable output fuse protection
- Low battery voltage disconnect
- Unit comes standard with electronic lockout and brownout circuits

### Controls

- Standard with a **non-audible improved self diagnostic & self-testing** microcontroller- based system
- Optional **audible Improved Diagnostic** available
- Optional **Non-Improved Diagnostics** available
- **Non-Improved Diagnostics** option for applications with emergency power controls
- Standard lighting control override for 0-10V dimming systems
- Optional 4 output circuits allow for multiple zone application
- Optional load shedding to dim 0-10V light fixtures connected to an emergency inverter system

### Load Shedding

- During a power outage the emergency fixture is dimmed at field selectable level of 25%, 40% or 45% brightness output. Reducing wattage draw from the fixture will allow for more fixture to be connected to the Mini Inverter.
- Lightalarms 1000W Mini Inverter with 4C-24V option must be used in conjunction with RTS load shedding control device (Ordered separately)
- The LMIU-1000-4C-24V when in normal mode can accept a maximum of 1000watts per circuit.
- Maximum 20 Emergency fixtures can be daisy chained to each RTS
- One RTS required for each circuit (Ordered separately)

For use of more than 4 RTS control devices contact factory

### Sealed maintenance-free battery

- 12V valve regulated Lead-Calcium (VRLA) batteries
- Provides minimum 90 minutes of emergency operation power requirements
- Choice of Voltage 120V input/120V output or 277V input/277V output operation, 60Hz

### Approvals

- UL 924 Standard
- Meets or exceeds all National Electric Code and Life Safety Code Emergency Lighting Requirements

**Warranty** (subject to proper installation and maintenance)

Unit has a three-year limited warranty

Detailed warranty terms located on **page 197** or online at: [www.lightalarms.com](http://www.lightalarms.com)



<sup>1</sup> When using hi-bay fixtures or screw-in type LED lamps, consult the factory.



**Replacement battery**

Series	Part number
LMIU-1000	4 X 860.0043

**Specifications**

Transfer time	Voltage regulation on emergency	Frequency regulation on emergency	Load power factor range	Operating temperature
Less than 1 second	+/- 3%	60 Hz +/- 1%	0.8 at 120V 1 at 277V	68°F to 86°F (20° to 30°C)

**Electrical characteristics and dimensions**

Power rating	Sine wave	Installation	Cabinet dimensions				Number of batteries	Weight	Weight w/o battery
			W"	H"	D"	120V & 277V		120V & 277V	
1000W	Pure	Floor/ Wall	24"	40.75"	10.5"	4	266 lbs	114 lbs	
1000W-4C	Pure	Floor/ Wall	24"	40.75"	14.5"	4	320 lbs	198 lbs	

Note: For wiring diagram, please refer to the specification sheets

**Power consumption and unit rating**

Model number	Ac specs	Emergency power available for load			
		90 minutes	2H	3H	4H
LMIU-1000	120 / 277VAC 12.8 / 5.3 Amps	1000W	807W	604W	489W

**Ordering format**

Series	Capacity	Voltage in/out	Diagnostic feature	Options
LMIU	-1000=1000W	Blank= 120/120VAC or 277/277VAC	Blank= Includes improved self-diagnostics (non-audible) <sup>1</sup> -ID= Improved self-diagnostics (audible) <sup>1</sup> -NID= No self-test/Self-diagnostic -NEX= Nexus® wired -NEXRF= Nexus® wireless	-D3= Time delay (15 minutes) -SAC= Service alarm contact <sup>2</sup> -4C= 4 output circuits -4C-24V= 4 output circuits with 24VDC output <sup>3</sup>

**Example: LMIU-1000-4C**

<sup>1</sup> Minimum load required: 10% of unit capacity

<sup>2</sup> Service alarm contact (SAC) shall be provided a 24V signal, the charger board will indicate a fault by closing a contact.

<sup>3</sup> Can only be used with RTS-0-10V-24-L for load shedding applications.

**RTS Series**

**0-10V dimming load shedding control**



**Ordering information**

Series
RTS-0-10V-24V-L= 24V 0-10V dimming load shedding control <sup>1</sup>

**Example: RTS-0-10V-24V-L**

<sup>1</sup> Can only be used with LMIU-1000-4C-24V



## Light Support Power Inverter Systems Features

### HIGHLIGHTS

#### Performance

The Light Support Power Systems works with any type of lighting load to provide full light output for minimum 90 min. It is designed to support incandescent, fluorescent, HID\*, quartz re-strike or halogen lamps. It will work into these loads at cold starts for all normally off circuits or normally on circuits. \*except IPS systems

#### True Sine waveform

Using a solid-state, pulse width modulation (PWM) inverter the systems produce pure sinusoidal output waveform with less than 3% maximum Total Harmonic Distortion (THD) for linear loads. Microprocessor and crystal controlled.

#### Reliability

The product is third generation inverter technology. Proven solid design with double ratings of all critical components. LVD (Low Voltage Disconnect) for long power outages eliminates battery drain.

#### Batteries

Front access connections for easy installation significantly reduce the footprint, installation and maintenance time while increasing safety. Automatic restart and recharge upon restoration of utility.

#### Approvals

- UL listed to UL924. Meets UL924, NFPA101, NFPA70, NFPA 110, OSHA, UBC, SBCCI.
- N.Y. City approved.

#### Applications

Light Support Power Systems can be used in almost every type of building, especially in architecturally sensitive applications or when maintenance costs and individual testing of unit equipment becomes very significant. Our systems are designed to work with power factor corrected as well as the most recent T5 and T5-HO electronic ballasts.

#### Options

A full range of options such as integrated output circuit breakers, bypass relays, dry contacts, etc., makes Light Support Power Systems an industry leader in emergency lighting central systems page 168.

### FEATURES

#### Self-Diagnostic/Self-Testing

Programmable monthly and annual self-testing. Proven self-diagnostic with over 120 parameters stored in separate memory logs for Test, Event and Alarm. Microprocessor monitoring and control.

#### Low heat dissipation

Very low heat loss technology in normal operating mode (see specifications for exact values). Convection cooling in normal mode with forced air during emergency mode. Battery cabinets: convection cooling only.

#### Maximum efficiency

- Highest efficiency in the industry, 98% at 100% load with no requirement for cooling in normal operating mode.
- Low input harmonic distortion <10%.

#### Versatile installation

Modular design, easy front access freestanding cabinets, fasten together when more than one cabinet is required. Optional seismic kit available. All wiring provided is pre cut and terminated, along with the necessary hardware and electrical fittings, for proper installation.

#### Complete protection

Input circuit breaker and fused battery circuit is standard. Systems offer overload capacity, short-circuit protection, current-limiting, low-battery disconnect, reverse polarity and brownout protection as standard.

#### Thermal performance

Bonded fin heat sink technology for maximum thermal performance. Cooling fans are energized only in inverter mode.

#### Monitoring and control

User friendly programmable interface with LED indicators and LCD display provides full metering values, easy program and control functions and a wide range of visual and audible alarms.

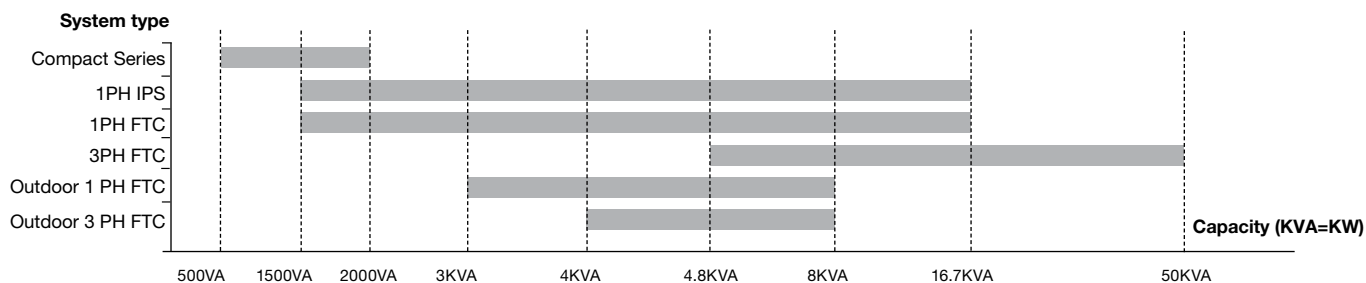

## Light Support Power Inverter Systems Benefits

### **BENEFITS**

#### **Compliance with NFPA101**

- The self-testing meets the requirements of NFPA and UL. User programmable time of testing.
- Test results, events or alarms can be downloaded from history logs. Load monitoring. Reduced testing/service time.

#### **Less air-conditioning**

Reduced costs for air-conditioning required to ensure the optimum operating temperature when compared with equivalent systems that dissipate much more heat. Higher reliability of fans and the electronic components.

#### **Lower energy bills**

Low consumption of the system itself will result in lower energy bills paid over the system life time. Comparative analysis available on request.

#### **Easy to install**

Quick installation and connection through flexible cable entries and fast access terminal blocks. Reduced footprint for systems with stackable cabinets. Low MTTR (<15 min.) due to modular design, quick disconnect means and frontal access.

#### **Reduced damage risks**

The full protection of the system will eliminate damage created by external events and will increase lifetime of the electronics and the batteries. Also will provide safety during maintenance.

#### **Increased MTBF**

- Increased reliability and reduced preventative maintenance.
- No air filters needed.

#### **Easy maintenance**

Easier diagnostic, troubleshooting, preventative maintenance and service through the indicators and display or by using the history logs. Remote versions available.



## Light Support Power Systems Compact Series

Single fast transfer emergency lighting, 1PH, inverter system 500VA – 2000VA



### Features

- 98% efficient at full load
- PWM/MOSFET technology
- Self-testing/Self-diagnostic
- User programmable with password protection
- Standard input circuit breaker
- Standard output circuit breaker
- Micro-processor controlled
- Floor or wall mountable
- Field upgradeable (500VA steps)
- 90 min. standard run time
- Electronic and magnetic ballast compatible
- Automatic event, test and alarm log
- LCD display
- Very small footprint (stackable cabinets)
- Maintenance free standard batteries
- Forced air cooling during emergency mode only

### Approvals

UL listed to UL924, Meets NFPA101, NFPA70, NFPA 110, OSHA, UBC, SBCCI. N.Y City approved



### Electrical/ mechanical characteristics<sup>4</sup> (data provided for standard lead calcium batteries)<sup>1,4</sup>

Power rating <sup>1</sup> VA=W	Effic. at full load	Max. input current (a)		Heat loss in normal mode (BTU/HR)	Batt. VDC	Batt. A	No. of batt.	UPS cabinet dimensions <sup>2,3</sup>			Battery cabinet dimensions <sup>2,3</sup>			No. of batt. cab	Batt. cab. weight lbs (empty)	UPS cab. weight lbs	Batt. weight lbs	Total system weight lbs
		120V	277V					W"	H"	D"	W"	H"	D"					
500	98	5.2	2.3	34	48	13.5	4	26	10	10	26	10	10	1	22	77	107	206
1000	98	10.5	4.5	68	48	26.5	8	26	10	10	26	10	10	2	22	77	214	335
1500	98	15.6	6.8	102	48	40	12	26	10	10	26	10	10	3	22	77	231	465
2000	98	20.8	9	136	48	52	16	26	10	10	26	10	10	4	22	77	428	592

<sup>1</sup> System capacity can be upgraded in the field up to 2000VA by adding more battery cabinets. Re-programming required by factory service technician

<sup>2</sup> Batteries are installed in separate modular cabinets

<sup>3</sup> Battery cabinets are stackable. Must be installed under the electronics cabinet

<sup>4</sup> Special voltages can change the size, weight or number of cabinets

### Ordering format

System type	Battery type	Input voltage <sup>3</sup>	VA/W rating	Output voltage <sup>3</sup>	Run time <sup>2</sup>	Input breaker	Output breakers <sup>4</sup>	Options <sup>1</sup>
<b>FTCM</b>	<b>-SC=</b> Sealed Lead-Calcium	<b>120=</b> 120VAC <b>277=</b> 277VAC	<b>C-</b> 500 <b>E-</b> 1000 <b>G-</b> 1500 <b>J-</b> 2000	<b>120</b> <b>277</b>	<b>90</b>	<b>ICB</b>	<b>OCBxxxx-</b> No trip alarm <b>OCAxxxx-</b> With trip alarmz	<b>FB-</b> Floor mount bracket <b>NOFF-</b> Normally OFF output <b>WB-</b> Wall mount bracket <b>DCS-</b> Dry summary alarm contacts <b>INVON-</b> Inverter on dry contact
								<b>VTD-</b> None variable <b>BPR-</b> Bypass relay <b>RMP-</b> Remote metering panel <b>RSAP-</b> Remote summary alarm panel <b>RS232-</b> Communicate interface <b>MOD-</b> Modem

**Example: FTCM-SC120G120-90-ICB-OCB0320-WB**

<sup>1</sup> See page 179 for options description

<sup>2</sup> Other run times available

<sup>3</sup> Special voltages may change the size, weight or number of cabinets

<sup>4</sup> Max. 3 more additional output breakers for a total of 4. See page 179 for output breakers details

**Specifications**

**GENERAL**

**Design**

Stand-by no break. PWM inverter type utilizing MOSFET technology with 2ms transfer time

**Control**

Microprocessor controlled, 2 x 20-character display with touch pad controls & functions

**Metering**

Input and output voltage, battery voltage, battery and output current, output VA, temperature, inverter wattage

**Communications**

Optional RS-232 port (DB9)

**ELECTRICAL INPUT**

**Voltage**

120 or 277VAC 1-phase 2-wire +10% - 15%. Contact factory for all other voltages.

**Input Power Walk-In**

- Limiting inrush current to less than 125%, 10 times for 1 line cycle
- Input frequency 60Hz, +/-3Hz
- Protection standard input circuit breaker
- Harmonic distortion <10%
- Power factor 0.5 lag/lead

**ELECTRICAL OUTPUT**

**Voltage**

120 or 277VAC 1-phase 2-wire. Contact factory for all other voltages.

**Static Voltage**

Load current change +/-2%, battery discharge +/-12.5%

**Dynamic Voltage**

- +/-2% for +/-25% load step change, +/-3% for a 50% load step change, recovery within 3 cycles
- Harmonic Distortion <3% THD for linear load
- Output Frequency 60Hz +/- 0.05Hz during emergency mode
- Load Power Factor 0.5 lag to 0.5 lead
- Inverter Overload 115% for 5 minutes
- Protection Standard Output Circuit Breaker (normally on)
- Crest Factor 2.8

**ENVIRONMENTAL CONDITIONS**

**Storage/Transport**

- -4°F to 158°F (-20°C to 70°C) without batteries
- -0°F to 104°F (-18°C to 40°C) with batteries (max. 3 months at 104° F (40° C)

**Operating temperature**

System operates safely from 32°F to 104°F (0°C to 40°C) but optimum operation is between 68° F and 86°F (20°C to 30°C). Battery performance can be affected by temperature.

**Altitude**

<10,000 feet (above sea level) without de-rating

**Relative Humidity**

- 0 to 95% non-condensing
- Audible noise 45 dBA @ 1m from surface in emergency mode

**Cabinets** Modular design, freestanding or wall mount NEMA type 1 steel cabinets powder coated for corrosion and scratch resistance. Front access design. Cabinets are stackable. Top and left side conduit entry with knockouts

**Inverter** - Using MOSFET/PWM technology the inverter converts the DC voltage supplied by the batteries to AC voltage of a precise stabilized amplitude and frequency, suitable for most sophisticated electrical equipment. True sinusoidal output waveform with very low distortion (less than 3% for linear loads). Overload capability of up to 150% for 12 line cycles.

**Charger** - Fully automatic, temperature compensated, microprocessor controlled charger recharges fully discharged batteries in maximum 24 hours at nominal AC input voltage. AC input current limiting and over-voltage protection included.

**Battery** - System is provided with 10 year, maintenance free, sealed valve regulated Lead-Calcium batteries. 90 min. standard discharge time at full load under normal operating temperature. Low Voltage Disconnect protection included. No special ventilation required.

**Supervision** - Automatic self-test consists of a 5-minute monthly and 90-minute annual function. The front-mounted control panel includes 5 LED indicators, a 2-line 20-character LCD display, a keypad to control and monitor the internal operation of the system. This allows the operator to easily "watch" system functions as they occur and check on virtually any aspect of the system's operation. Self-diagnostic function monitors, controls, generates alarms and memorizes events.

**Alarms** - High/Low Battery Charger Voltage, High/Low AC Input Voltage, Near Low Battery, Low Battery, Load Reduction Fault, Output Overload, High Ambient Temperature, Inverter Fault, Output Fault, Optional Output Circuit Breaker Trip

**Optional features** - Normally OFF output, Output Circuit Breakers, Output Trip Alarm, RS232 communication port, 12 Hours Fast Recharge, Remote Meter Panel, Remote Summary Alarm Panel, Summary Alarm Dry Form C Contact, Inverter on Dry Contacts, Variable Time Delay, Modem, Bypass Relays, Wall mount bracket

**Factory start-up** - Includes one additional year of warranty. See warranty conditions.

**Warranty** - Limited manufacturer warranty is one-year, parts and labor, for system electronics or two-year with factory start-up program. Battery warranty is one-year full plus 9 years pro-rata for a total of 10 years, under normal operating conditions. System must be put in service within 180 days from ship date in order to validate warranty.

Detailed warranty terms located on page 197 or online at: [www.lightalarms.com](http://www.lightalarms.com)

**Single line diagram**

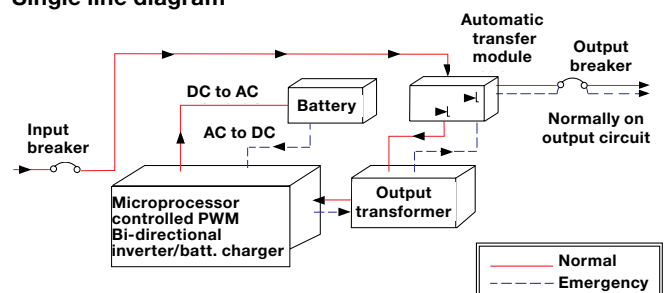

Characteristics, specifications or dimensions subject to change without notice.

## Light Support Power Systems IPS Single Phase Series

Interruptible emergency lighting inverter system 1.5KVA –16.7KVA



### Features

- 98% efficient at full load
- PWM/IGBT technology
- Self-testing/Self-diagnostic
- User programmable with password protection
- Standard input circuit breaker
- Standard internal bypass switch
- RS232 communication port
- Micro-processor controlled
- Automatic event and alarm log
- 90 min. standard run time
- Generator compatibility
- Available in Y or Δ input configuration
- Custom voltages available
- Automatic event, test and alarm log
- LCD display
- Reduced footprint
- Maintenance free standard batteries
- Forced air cooling during emergency only



### Electrical/ mechanical characteristics<sup>4</sup> (data provided for standard lead calcium batteries)<sup>1,4</sup>

Power rating <sup>1</sup> kVA=kW	Effic. at full load	Max. input current (a)		Heat loss in normal mode (BTU/HR)	Batt. VDC	Batt. A	No. of batt.	UPS cabinet			Battery cabinet dimensions <sup>2,3</sup>			No. of batt. cab	Batt. cab. weight lbs (empty)	UPS cab. weight lbs	Batt. system weight lbs	Total system weight lbs
		120V	277V					W"	H"	D"	W"	H"	D"					
1.5	98	16	7	102	48	39	4	30	47	25	N/A	N/A	N/A	N/A	N/A	296	296	546
2.25	98	24	11	153	72	38	6	30	47	25	N/A	N/A	N/A	N/A	N/A	444	444	709
3	98	32	14	204	96	38	8	30	47	25	N/A	N/A	N/A	N/A	N/A	592	592	887
3.75	98	39	17	255	120	37	10	30	47	25	N/A	N/A	N/A	N/A	N/A	740	740	1045
5	98	50	22	340	144	40	12	30	47	25	N/A	N/A	N/A	N/A	N/A	888	888	1203
6	98	63	27	408	180	40	15	30	47	25	30	47	25	1	210	1110	1110	1670
8	98	84	36	544	240	39	20	30	47	25	30	47	25	1	232	1480	1480	2087
10	98	105	45	680	144	82	24	30	47	25	30	47	25	1	420	1776	1776	2631
12.5	98	131	57	850	180	82	30	30	47	25	30	47	25	2	420	2220	2220	3105
16.7	98	174	76	1136	240	80	40	30	47	25	30	47	25	2	464	2960	2960	3954

<sup>1</sup> Consult factory for 20 year type batteries

<sup>2</sup> Batteries are installed in the electronics cabinet for 1.5 to 5kVA systems

<sup>3</sup> Battery cabinets are stackable. To be installed on the right side of the electronics cabinet

<sup>4</sup> Special voltages or batteries may change the size, weight or number of cabinets

### Ordering format

System type	Battery type	Input voltage <sup>3</sup>	VA/W rating	Output voltage <sup>3</sup>	Run time <sup>2</sup>	Input breaker	RS232 port	Output breakers <sup>4</sup>	Options <sup>1</sup>
IPS	SC= Sealed	120	G- 1500	120	90	ICB	RS232	OCBxxxx- No trip alarm	20Y- 20 yr sealed batteries
	Lead-	208	K- 2250	277				12HR- 12 hr fast recharge	VTD- Time delay, 15 min.
	Calcium	240	L- 3000	208				MBYP- Internal bypass switch	MOD- External modem
		277	M- 3750	120/240				OCAxxxx- With trip alarm	FAX- Fax modem
			P- 5000	120/277				EMBP- External bypass switch <sup>5</sup>	BPR- Bypass relays
			R- 6000					RMP- Remote metering panel	SEIS- Seismic mounting
			S- 8000					RSAP- Remote summary alarm panel	ZONEM- Zone monitoring
		T- 10000					DCS- Dry summary alarm contacts	BATM- Battery cycle warranty monitor	
		U- 12500					INVON- Inverter on dry contacts		
		V- 16700							

**Example: IPS-SC120S120-90-ICB-RS232-OCB0420-DCS-20Y**

<sup>1</sup> See page 179 for options description

<sup>2</sup> Other run times available

<sup>3</sup> Special voltages may change the size, weight or number of cabinets

<sup>4</sup> Max. 12 unsupervised single pole positions or 8 with trip alarm. For more output breakers please consult factory. See page 179 for output breakers option details.

<sup>5</sup> External bypass switch is not compatible with integrated output circuit breakers. Input/output voltage has to be the same

**Specifications**

**GENERAL**

**Design**

Stand-by. PWM inverter type utilizing IGBT technology with 50ms transfer time

**Control**

- Microprocessor controlled, 2 x 20-character display with touch pad controls & functions
- 5 LED indicators & alarm with ring-back feature

**Metering**

Input & Output Voltage, Battery Voltage, Battery & Output Current, Output VA, temperature, inverter wattage

**Communications**

RS-232 port (DB9)

**ELECTRICAL INPUT**

**Voltage**

120 or 277VAC 1-phase 2-wire +10% - 15%. Contact factory for all other voltages.

**Input Power Walk-In**

Limiting inrush current to less than 125%, 10 times for 1 line cycle

**Input Frequency**

- 60Hz, +/-3%, 50Hz available upon request
- Protection 60Hz, +/-3%, 50Hz available upon request
- Harmonic Distortion <10%
- Power Factor 0.5 lag/lead

**ELECTRICAL OUTPUT**

**Voltage**

120 or 277VAC 1-phase 2-wire. Contact factory for all other voltages.

**Static Voltage**

Load current change +/-2%, battery discharge +/-12.5%

**Dynamic Voltage**

- +/-2% for +/-25% load step change, +/-3% for a 50% load step change, recovery within 3 cycles
- Harmonic Distortion <3% THD for linear load
- Output Frequency 60Hz +/- 0.05Hz during emergency mode
- Inverter Overload 125% for 5 minutes
- Protection Optional Distribution Circuit Breaker
- Crest Factor 2.8

**ENVIRONMENTAL CONDITIONS**

**Storage/Transport**

- -4°F to 158°F (-20°C to 70°C) without batteries
- -0°F to 104°F (-18°C to 40°C) with batteries (max. 3 months at 104° F (40° C)

**Operating temperature**

System operates safely from 32°F to 104°F (0°C to 40°C) but optimum operation is between 68° F and 86°F (20°C to 30°C).

Battery performance can be affected by temperature.

**Altitude**

<10,000 feet (above sea level) without de-rating

**Relative Humidity**

0 to 95% non-condensing

**Audible noise**

45 dBA @ 1m from surface in emergency mode

**Cabinets** - Modular design, freestanding NEMA type 1 steel cabinets powder coated for corrosion and scratch resistance. Front access design through hinged lockable doors requires only 39" front clearance and 12" top clearance. Cabinets are stackable up to 16.7kVA, if required to further reduce the footprint. Top and left side conduit entry with knockouts up to 16.7kVA. Left side only for 24kVA and up.

**Inverter** - Using IGBT/PWM technology the inverter converts DC voltage supplied by the batteries to AC voltage of a precise stabilized amplitude and frequency, suitable for most sophisticated electrical equipment. True sinusoidal output waveform with very low distortion (less than 3% for linear loads). Overload capability of up to 150% for 12 line cycles.

**Charger** - Fully automatic, temperature compensated, microprocessor controlled charger recharges fully discharged batteries in maximum 24 hours at nominal AC input voltage. AC input current limiting and over-voltage protection included.

**Battery** - System is provided standard with 10 year, maintenance free, sealed valve regulated, front terminals Lead-Calcium batteries. 20 years life sealed Lead-Calcium battery also available. 90 min. standard discharge time at full load under normal operating temperature. Low Voltage Disconnect protection included. No special ventilation required.

**Supervision** - Automatic self tests consist of a 5-minute monthly and 90-minute annual function. The front-mounted control panel includes 5 LED indicators, a 2-line 20-character LCD display, a keypad to control and monitor the internal operation of the system. This allows the operator to easily "watch" system functions as they occur and check on virtually any aspect of the system's operation. Standard RS232 diagnostic interface.

**Alarms** - High/Low Battery Charger Voltage, High/Low AC Input Voltage, Near Low Battery, Low Battery, Load Reduction Fault, Output Overload, High Ambient Temperature, Inverter Fault, Output Fault, Optional Output Circuit Breaker Trip

**Optional features** - Output Circuit Breakers, Output Trip Alarms, 20 Years Sealed Batteries, 12 Hours Fast Recharge, Internal/External Maintenance Bypass Switch, Remote Meter Panel, Remote Summary Alarm Panel, Summary Alarm Dry Form C Contact, Inverter on Dry Contacts, Fax/Modem, Bypass Relays, Auto Dialer, Seismic Mounting.

**Factory start-up** - full limited warranty conditions available upon request) Includes one additional year of warranty. See warranty conditions.

**Warranty** (full limited warranty conditions available upon request)

Limited manufacturer warranty is one-year, parts and labor, for system electronics or two-year with factory start-up program. Battery warranty is one-year full plus 9 years pro-rata for a total of 10 years, under normal operating conditions. System must be put in service within 6 months from ship date in order to validate warranty. 2- Consult factory for other type batteries than the standard one.

Detailed warranty terms located on page 197 or online at: [www.lightalarms.com](http://www.lightalarms.com)

**Single line diagram**

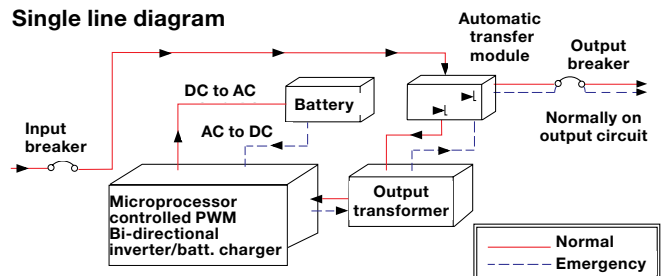

Characteristics, specifications or dimensions subject to change without notice.

## FTC Single Phase Series

Fast transfer emergency lighting inverter system 1.5KVA –16.7KVA



### Features

- 98% efficient @ full load
- PWM/IGBT technology
- Self-testing/Self-diagnostic
- User programmable with password protection
- Standard input circuit breaker
- RS232 communication port
- Micro-processor controlled
- Automatic event and alarm log
- 90 min. standard run time
- Generator compatibility
- Electronic and magnetic ballast compatible

- Custom voltages available
- Automatic event, test and alarm log
- LCD display
- Reduced footprint (stackable cabinets)
- Maintenance free standard batteries
- Forced air cooling during emergency mode only



### Electrical characteristics and dimensions<sup>4</sup> (data provided for standard lead calcium batteries)<sup>1,4</sup>

Power rating <sup>1</sup> kVA=kW	Effic. at full load	Max. input current (a)		Heat loss in normal mode (BTU/HR)	Batt. VDC	Batt. A	No. of batt.	UPS cabinet			Battery cabinet dimensions <sup>2,3</sup>			No. of batt. cab	Batt. cab. weight lbs (empty)	UPS cab. weight lbs	Batt. weight lbs	Total system weight lbs
		120V	277V					W"	H"	D"	W"	H"	D"					
1.5	98	16	7	102	48	39	4	30	47	25	N/A	N/A	N/A	N/A	N/A	250	296	546
2.25	98	24	11	153	72	38	6	30	47	25	N/A	N/A	N/A	N/A	N/A	265	444	709
3	98	32	14	204	96	38	8	30	47	25	N/A	N/A	N/A	N/A	N/A	295	592	887
3.75	98	39	17	255	120	37	10	30	47	25	N/A	N/A	N/A	N/A	N/A	305	740	1045
5	98	50	22	340	144	40	12	30	47	25	N/A	N/A	N/A	N/A	N/A	315	888	1203
6	98	63	27	408	180	40	15	30	47	25	30	47	25	1	210	350	1110	1670
8	98	84	36	544	240	39	20	30	47	25	30	47	25	1	232	375	1480	2087
10	98	105	45	680	144	82	24	30	47	25	30	47	25	1	420	435	1776	2631
12.5	98	131	57	850	180	82	30	30	47	25	30	47	25	2	420	465	2220	3105
16.7	98	174	76	1136	240	80	40	30	47	25	30	47	25	2	464	530	2960	3954

<sup>1</sup> Consult factory for 20 year type batteries

<sup>2</sup> Batteries are installed in the electronics cabinet for 1.5 to 5kVA systems

<sup>3</sup> Battery cabinets are stackable. To be installed on the right side of the electronics cabinet.

<sup>4</sup> Special voltages or batteries may change the size, weight or number of cabinets

### Ordering format

System type	Battery type	Input voltage <sup>3</sup>	VA/W rating	Output voltage <sup>3</sup>	Run time <sup>2</sup>	Input breaker	RS232 port	Output breakers <sup>4</sup>	Options <sup>1</sup>	
<b>FTC</b>	<b>SC=</b> Sealed Lead-Calcium	<b>120</b> <b>208</b> <b>240</b> <b>277</b>	<b>G-</b> 1500 <b>K-</b> 2250 <b>L-</b> 3000 <b>M-</b> 3750 <b>P-</b> 5000 <b>R-</b> 6000 <b>S-</b> 8000 <b>T-</b> 10000 <b>U-</b> 12500 <b>V-</b> 16700	<b>120</b> <b>277</b> <b>208</b> <b>120/240</b> <b>120/277</b>	<b>90</b>	<b>ICB</b>	<b>RS232</b>	<b>OCBxxxx-</b> No trip alarm <b>OCAXxxx-</b> With trip alarm	<b>20Y-</b> 20 yr sealed batteries <b>12HR-</b> 12 hr fast recharge <b>MBYP-</b> Internal bypass switch <b>EMBP-</b> External bypass switch <sup>5</sup> <b>RMP-</b> Remote metering panel <b>RSAP-</b> Remote summary alarm panel <b>DCS-</b> Dry summary alarm contacts <b>INVON-</b> Inverter on dry contacts	<b>MOD-</b> External modem <b>FAX-</b> Fax modem <b>BPR-</b> Bypass relays <b>SEIS-</b> Seismic mounting <b>ZONEM-</b> Zone monitoring <b>BATM-</b> Battery cycle warranty monitor <b>NOFF-</b> Normally Off output <sup>6</sup>

**Example: FTC-SC120M12090ICBRS232-OCB0420**

<sup>1</sup> See page 179 for options description

<sup>2</sup> Other run times available

<sup>3</sup> Special voltages may change the size, weight or number of cabinets

<sup>4</sup> Max. 12 unsupervised single pole positions or 8 with trip alarm. For more output breakers please consult factory. See page 179 for output breakers option details.

<sup>5</sup> External bypass switch is not compatible with integrated output circuit breakers. Input/output voltage has to be the same

<sup>6</sup> Normally Off loads cannot exceed 20% of total KVA rating with any combination of H.I.D loads



**Specifications**

**GENERAL**

**Design**

Stand-by. PWM inverter type utilizing IGBT technology with 2ms transfer time.

**Control**

- Microprocessor controlled , 2 x 20-character display with touch pad controls & functions
- 5 LED indicators & alarm with ring-back feature

**Metering**

Input and output Voltage, battery voltage, battery and output current, output VA, temperature, inverter wattage

**Communications** RS-232 port (DB9)

**ELECTRICAL INPUT**

**Voltage**

120 or 277VAC 1-phase 2-wire +10% - 15%. Contact factory for all other voltages.

**Input Power Walk-In**

Limiting inrush current to less than 125%, 10 times for 1 line cycle

**Input Frequency**

- 60Hz, +/-3%, 50Hz available upon request
- Protection Input Circuit Breaker
- Harmonic Distortion <10%
- Power Factor 0.5 lag/lead

**ELECTRICAL OUTPUT**

**Voltage**

120 or 277VAC 1-phase 2-wire. Contact factory for all other voltages.

**Static Voltage**

Load current change +/-2%, battery discharge +/-12.5%

**Dynamic Voltage**

- +/-2% for +/-25% load step change
- +/-3% for a 50% load step change, recovery within 3 cycles
- Harmonic Distortion <3% THD for linear load
- Output Frequency 60Hz +/- 0.05Hz during emergency mode
- Load Power Factor 0.5 lag to 0.5 lead
- Inverter Overload 125% for 5 minutes
- Protection Optional Distribution Circuit Breaker
- Crest Factor 2.8

**ENVIRONMENTAL CONDITIONS**

**Storage/Transport**

- -4°F to 158°F (-20°C to 70°C) without batteries
- -0°F to 104°F (-18°C to 40°C) with batteries (max. 3 months at 104° F (40° C)

**Operating temperature**

System operates safely from 32°F to 104°F (0°C to 40°C) but optimum operation is between 68° F and 86°F (20°C to 30°C). Battery performance can be affected by temperature.

**Altitude**

<10,000 feet (above sea level) without de-rating

**Relative Humidity**

0 to 95% non-condensing

**Audible noise**

45 dBA @ 1m from surface in emergency mode

**Cabinets** - Modular design, freestanding NEMA type 1 steel cabinets powder coated for corrosion and scratch resistance. Front access design through hinged lockable doors requires only 39" front clearance and 12" top clearance. Cabinets are stackable if required to further reduce the footprint. Top and left side conduit entry with knockouts.

**Inverter** - Using IGBT/PWM technology the inverter converts the DC voltage supplied by the batteries to AC voltage of a precise stabilized amplitude and frequency, suitable for most sophisticated electrical equipment. True sinusoidal output waveform with very low distortion (less than 3% for linear loads). Overload capability of up to 150% for 12 line cycles.

**Charger** - Fully automatic, temperature compensated, microprocessor controlled charger recharges fully discharged batteries in maximum 24 hours at nominal AC input voltage. AC input current limiting and over-voltage protection included.

**Battery** - System is provided standard with 10 year, maintenance free, sealed valve regulated, front terminals lead calcium batteries. 20 years life sealed lead calcium battery also available. 90 min. standard discharge time at full load under normal operating temperature. Low Voltage Disconnect protection included. No special ventilation required.

**Supervision** - Automatic self tests consist of a 5-minute monthly and 90-minute annual function. The front-mounted control panel includes 5 LED indicators, a 2-line 20-character LCD display, a keypad to control and monitor the internal operation of the system. This allows the operator to easily "watch" system functions as they occur and check on virtually any aspect of the system's operation. Standard RS232 diagnostic interface.

**Alarms** - High/Low Battery Charger Voltage, High Low AC Input Voltage, Near Low Battery, Low Battery, Load Reduction Fault, Output Overload, High Ambient Temperature, Inverter Fault, Output Fault, Optional Output Circuit Breaker Trip .

**Optional features** - Output Circuit Breakers, Output Trip Alarms, 20 Years Sealed Batteries, 12 Hours Fast Recharge, Internal/ External Maintenance Bypass Switch, Remote Meter Panel, Remote Summary Alarm Panel, Summary Alarm Dry Form C Contact, Inverter on Dry Contacts, Normally OFF output, Fax/Modem, Bypass Relays, Auto Dialer, Seismic Mounting.

**Factory start-up** - (Includes one additional year of warranty. See warranty conditions.

**Warranty** (full limited warranty conditions available upon request) Limited manufacturer warranty is one-year, parts and labor, for system electronics or two-year with factory start-up program. Battery warranty is one-year full plus 9 years pro-rata for a total of 10 years, under normal operating conditions. System must be put in service within 6 months from ship date in order to validate warranty. 2- Consult factory for other type batteries than the standard one

Detailed warranty terms located on page 197 or online at: [www.lightalarms.com](http://www.lightalarms.com)

**Single line diagram**

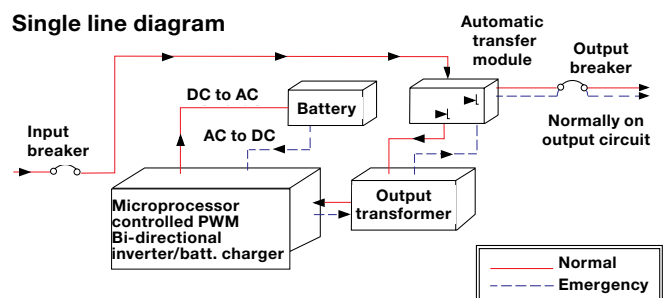

## Light Support Power Systems 3FTC Three Phase Series

Fast transfer emergency lighting inverter system 4.8KVA – 50KVA



### Features

- 98% efficient @ full load
- PWM/IGBT technology
- Self-testing/Self-diagnostic
- User programmable with password protection
- Standard input circuit breaker
- Standard internal bypass switch
- RS232 communication port
- Micro-processor controlled
- Automatic event and alarm log
- 90 min. standard run time
- Generator compatibility
- Available in Y or Δ input configuration
- Custom voltages available
- Automatic event, test and alarm log
- LCD display
- Reduced footprint (stackable cabinets)
- Maintenance free standard batteries
- Forced air cooling during emergency mode only



Electrical characteristics and dimensions<sup>4</sup> (data provided for standard lead calcium batteries)<sup>1,4</sup>

Power rating <sup>1</sup> kVA=kW	Effic. at full load %	Max. input current (a)		Heat loss in normal mode (BTU/HR)	Batt. VDC	Batt. A	No. of batt.	UPS cabinet			Battery cabinet dimensions <sup>2,3</sup>			No. of batt. cab	Batt. cab. weight lbs (empty)	UPS cab. weight lbs	Batt. system weight lbs	Total weight lbs
		120V/208V	277V/480V					W"	H"	D"	W"	H"	D"					
4.8	98	17	7	326	144	39	12	30	47	25	30	47	25	1	N/A	535	888	1633
6	98	21	9	408	180	39	15	30	47	25	30	47	25	1	N/A	535	1110	1855
8	98	28	12	544	240	39	20	30	47	25	30	47	25	1	N/A	535	1480	2247
10	98	35	15	680	144	81	24	30	47	25	30	47	25	1	N/A	639	1776	2835
12.5	98	43	19	850	180	81	30	30	47	25	30	47	25	2	N/A	639	2220	3279
16.7	98	58	25	1136	240	81	40	30	47	25	30	47	25	2	210	639	2960	4063
24	98	84	36	1632	240	117	60	30	72	31	48	72	31	1	232	1250	4440	6390
33	98	115	50	2244	240	160	40	30	72	31	48	72	31	2	420	1250	6080	8630
40	98	139	60	2720	240	194	100	30	72	31	48	72	31	2	420	1250	7400	10150
50	98	174	75	3400	240	243	60	30	72	31	48	72	31	2	464	1250	9120	11980

<sup>1</sup> Consult factory for 20 year type batteries

<sup>2</sup> Batteries are installed in the electronics cabinet for 1.5 to 5KVA systems

<sup>3</sup> Battery cabinets are stackable. To be installed on the right side of the electronics cabinet.

<sup>4</sup> Special voltages or batteries may change the size, weight or number of cabinets

### Ordering format

System type	Battery type	Input voltage <sup>3</sup>	VA/W rating	Output voltage <sup>3</sup>	Run time <sup>2</sup>	Input breaker	RS232 port	Internal Bypass Switch	Output breakers <sup>4</sup>	Options <sup>1</sup>
<b>3FTC</b>	<b>SC=</b> Sealed Lead- Calcium	<b>120/208</b> <b>277/480</b>	<b>N-</b> 4800 <b>R-</b> 6000 <b>S-</b> 8000 <b>T-</b> 10000 <b>U-</b> 125000 <b>V-</b> 167000 <b>X-</b> 24000 <b>Z-</b> 40000 <b>W-</b> 50000	<b>120/208</b> <b>277/480</b>	<b>90</b>	<b>ICB</b>	<b>RS232</b>	<b>MBYP</b>	<b>OCBxxx-</b> No trip alarm  <b>OCAxxx-</b> With trip alarm	<b>20Y-</b> 20 yr sealed batteries <b>12HR-</b> 12 hr fast recharge <b>NOFF-</b> Normally Off output 1PH <sup>6</sup> <b>EMBP-</b> External bypass switch <sup>5</sup> <b>RMP-</b> Remote metering panel <b>RSAP-</b> Remote summary alarm panel <b>DCS-</b> Dry summary alarm contacts <b>INVON-</b> Inverter on dry contacts <b>NOFF3-</b> Normally OFF output 3PH <sup>3</sup> <b>MOD-</b> External modem <b>FAX-</b> Fax modem <b>BPR-</b> Bypass relays <b>BATM-</b> Battery cycle warranty monitor
										<b>MOD-</b> External modem <b>FAX-</b> Fax modem <b>BPR-</b> Bypass relays <b>SEIS-</b> Seismic mounting <b>ZONEM-</b> Zone monitoring

**Example: 3FTC-SC277/480V277/480-90-ICB-RS232-MBYP-OCB1220-DCS-20Y**

<sup>1</sup> See page 179 for options description. Summary alarm dry contacts and seismic brackets are standard

<sup>2</sup> Other run times available

<sup>3</sup> 1PH are input voltages available for 1 phase systems. 2PH are input voltages available for 3 phase systems.

<sup>4</sup> Max. 14 unsupervised single pole positions or 8 with trip alarm. See page 179 for output breakers option details.

<sup>5</sup> Not available in 3 Phase version

<sup>6</sup> Normally Off loads cannot exceed 20% of total KVA rating with any combination of H.I.D loads

**Specifications**

**GENERAL**

**Design**

Stand-by. PWM inverter type utilizing IGBT technology with 2ms transfer time.

**Control**

- Microprocessor controlled , 2 x 20-character display with touch pad controls & functions
- 5 LED indicators & alarm with ring-back feature

**Metering**

Input & Output Voltage, Battery Voltage, Battery & Output Current, Output VA, temperature, communications

**Communications** RS-232 port (DB9)

**ELECTRICAL INPUT**

**Voltage**

120/208 or 277/480 3 phase 4-wire +10% - 15%. Contact factory for all other voltages.

**Input Power Walk-In**

Limiting inrush current to less than 125%, 10 times for 1 line cycle

**Input Frequency**

- 60Hz, +/-3%, 50Hz available upon request
- Protection Input Circuit Breaker
- Harmonic Distortion <10%
- Power Factor 0.5 lag/lead

**ELECTRICAL OUTPUT**

**Voltage**

120 or 277VAC 1-phase 2-wire. Contact factory for all other voltages.

**Static Voltage**

Load current change +/-4%, battery discharge +/-4%

**Dynamic Voltage**

- +/-3% for +/-25% load step change,
- +/-6% load step change, recovery within 3 cycles
- Harmonic Distortion <3% THD for linear load
- Output Frequency 60Hz +/- 0.05Hz during emergency mode
- Load Power Factor 0.5 lag to 0.5 lead
- Inverter Overload 115% for 5 minutes
- Protection Optional Distribution Circuit Breaker
- Crest Factor 2.8

**ENVIRONMENTAL CONDITIONS**

**Storage/Transport**

- -4°F to 158°F (-20°C to 70°C) without batteries (max. 3 months at 104° F (40° C)
- -0°F to 104°F (-18°C to 40°C) with batteries

**Operating temperature**

System operates safely from 32°F to 104°F (0°C to 40°C) but optimum operation is between 68° F and 86°F (20°C to 30°C). Battery performance can be affected by temperature.

**Altitude**

<10,000 feet (above sea level) without de-rating

**Relative Humidity**

0 to 95% non-condensing

**Audible noise**

45 dBA @ 1m from surface in emergency mode

**Cabinets** - Modular design, freestanding NEMA type 1 steel cabinets powder coated for corrosion and scratch resistance. Front access design through hinged lockable doors requires only 39" front clearance and 12" top clearance. Cabinets are stackable up to 16.7kVA, if required to further reduce the footprint. Top and left side conduit entry with knockouts up to 16.7kVA. Left side only for 24kVA and up.

**Inverter** - Using IGBT/PWM technology the inverter converts the DC voltage supplied by the batteries to AC voltage of a precise stabilized amplitude and frequency, suitable for most sophisticated electrical equipment. True sinusoidal output waveform with very low distortion (less than 3% for linear loads). Overload capability of up to 150% for 12 line cycles.

**Charger** - Fully automatic, temperature compensated, microprocessor controlled charger recharges fully discharged batteries in maximum 24 hours at nominal AC input voltage. AC input current limiting and over-voltage protection included

**Battery** - System is provided standard with 10 year, maintenance free, sealed valve regulated, front terminals lead calcium batteries. 20 years life sealed lead calcium battery also available. 90 min. standard discharge time at full load under normal operating temperature. Low Voltage Disconnect protection included. No special ventilation or filters required.

**Supervision** - Automatic self tests consist of a 5-minute monthly and 90-minute annual function. The front-mounted control panel includes 5 LED indicators, a 2-line 20-character LCD display, a keypad to control and monitor the internal operation of the system. This allows the operator to easily "watch" system functions as they occur and check on virtually any aspect of the system's operation. Standard RS232 diagnostic interface

**Alarms** - High/Low Battery Charger Voltage, High/Low AC Input Voltage, Near Low Battery, Low Battery, Load Reduction Fault, Output Overload, High Ambient Temperature, Inverter Fault, Output Fault, Optional Output Circuit Breaker Trip.

**Optional features** - Output Circuit Breakers, Output Trip Alarms, 20 Years Sealed Batteries, 12 Hours Fast Recharge, External Maintenance Bypass Switch, Remote Meter Panel, Remote Summary Alarm Panel, Summary Alarm Dry Form C Contact, Inverter on Dry Contacts, Normally OFF output, Fax/Modem, Bypass Relays, Auto Dialer, Seismic Mounting.

**Factory start-up** - (Includes one additional year of warranty. See warranty conditions.

**Warranty** Limited manufacturer warranty is one-year, parts and labor, for system electronics or two-year with factory start-up program. Battery warranty is one year full plus 9 years pro-rata for a total of 10 years, under normal operating conditions. System must be put in service within 6 months from ship date in order to validate warranty. 2- Consult factory for other type batteries than the standard one.

Detailed warranty terms located on page 197 or online at: [www.lightalarms.com](http://www.lightalarms.com)

**Single line diagram**

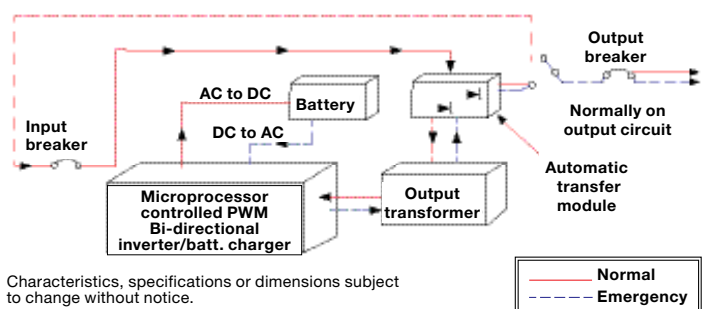

Characteristics, specifications or dimensions subject to change without notice.

## Light Support Power Systems FTC3R & 3FTC3R

Outdoor fast transfer emergency lighting Inverter system 3KVA – 8KVA



### Features

- 98% efficient @ full load
- PWM/IGBT technology
- Self-testing/Self-diagnostic
- Standard input circuit breaker
- Standard internal bypass switch
- RS232 communication port
- Standard seismic zone 4 brackets
- Standard summary dry contacts
- Automatic event and alarm log
- NEMA 3R cabinet for outdoors
- 90 min. standard run time

- Generator compatibility
- Custom voltages available
- Automatic event, test and alarm log
- LCD display
- One size cabinet
- Maintenance free standard 5 year
- Temperature controlled cooling fans



### Electrical characteristics and dimensions<sup>4</sup> (data provided for standard lead calcium batteries)<sup>1, 4</sup>

Power rating <sup>1</sup> kVA=kW	Effic. at full load	Heat loss in normal mode		Batt. VDC	Batt. A	No. of Batt. <sup>2</sup>	UPS cabinet dimensions			Batt. cab. weight lbs (empty)	UPS cab. weight lbs	Batt. weight lbs	Total system weight lbs
		BTU/HR	BTU				W" <sup>3</sup>	H"	D"				
3 (1PH)	98	255	120	120	37	10	48	76	30	N/A	535	888	1633
4 (1PH)	98	340	144	144	40	12	48	76	30	N/A	535	1110	1855
5 (1PH)	98	408	180	180	40	15	48	76	30	N/A	535	1480	2247
6.5 (1PH)	98	544	240	240	39	20	48	76	30	N/A	639	1776	2835
8 (1PH)	98	680	144	144	82	24	48	76	30	N/A	639	2220	3279
4 (3PH)	98	326	144	144	39	12	48	76	30	210	639	2960	4063
5 (3PH)	98	408	180	180	39	15	48	76	30	232	1250	4440	6390
6.5 (3PH)	98	544	240	240	39	20	48	76	30	420	1250	6080	8630
8 (3PH)	98	680	144	144	81	24	48	76	30	420	1250	7400	10150

<sup>1</sup> Factory installed floor mount brackets; add 2.5" to each side (total 53")

<sup>2</sup> Standard batteries are 5 year life expectancy.

Batteries are installed in the same cabinet with electronics

<sup>3</sup> UL rated for 90 min. run time for temperatures: 50°F to 104°F (10°C to 40°C) or -4°F to 104°F (-20°C to 40°C) with optional heater

<sup>4</sup> NEMA type 3R, freestanding, two-door powder coat cold rolled steel cabinet standard. Stainless steel enclosure is optional.

### Ordering format

System type	Battery type	Input voltage <sup>3</sup>	VA/W rating <sup>5</sup>	Output voltage <sup>3</sup>	Run time <sup>2</sup>	Input breaker	RS232 port	Internal bypass switch	Output breakers <sup>4</sup>	Options <sup>7</sup>	
FTC3R- single phase	SC= Sealed	120, 1PH	L- 3000	120	90	ICB	RS232	MBYP	OCBxxxx- No trip alarm OCAxxxx- With trip alarm	10Y- 10 yr sealed batteries 12HR- 12 hr fast recharge NOFF- Normally off output <sup>6</sup> EMBP- External bypass switch <sup>5</sup> RMP- Remote metering panel RSAP- Remote summary alarm panel	HTR- Heater INVON- Inverter on dry contacts MOD- External modem FAX- Fax modem BPR- Bypass relays SS- Stainless steel enclosure
	Lead-	208, 1PH	M- 3750	208							
	Calcium	240, 1PH	P- 5000	277							
3FTC3R- 3 phase		277, 1PH 120/208, 3PH 277/480, 3PH	R- 6000 S- 8000	120/208 277/480							

**Example: FTC3R-SC277P277-90-ICB-RS232-MBYP-OCB1020-10Y**

<sup>1</sup> 1PH are input voltages available for 1 phase systems. 3PH are input voltages available for 3phase systems.

<sup>2</sup> Other run times available

<sup>3</sup> 1PH are input voltages available for 1 phase systems. 3PH are input voltages available for 3phase systems.

<sup>4</sup> Max. 14 unsupervised single pole positions or 8 with trip alarm. For more output breakers please consult factory. See page 179 for output breakers option details.

<sup>5</sup> Not available in 3 phase version

<sup>6</sup> Normally Off loads cannot exceed 20% of total KVA rating with any combination of H.I.D loads

<sup>7</sup> See page 179 for options description. Summary alarm dry contacts and seismic brackets are standard.

## Light Support Power Systems Options

-OCB	12	20			
<b>Trip Alarm</b>	<b>Number of Circuit Breakers</b>	<b>Breaker Rating (Amps)</b>	<b>Number of poles</b>	<b>Breaker Voltage</b>	
<b>OCB - No Breaker Trip Alarm</b>	Combination of 1 pole, 2 pole and 3 pole breakers available.			Blank - matches system output voltage	
<b>OCA - With Breaker Trip Alarm</b>	*For max. number of circuit breakers available please consult factory	*Various ratings available	<b>Blank - 1 pole</b>	<b>-120VAC</b>	<b>-208VAC</b>
			<b>-2P - 2 poles</b>	<b>-240VAC</b>	<b>-277VAC</b>
			<b>-3P - 3poles</b>	<b>-480VAC</b>	
					<b>Operation Mode</b>
					<b>Blank:</b> Normally-On
					<b>-NOFF:</b> Normally-Off

Distribution circuit breakers are for output load protection. Protection for the normally on and/or for the normally off loads. All circuit breakers are rated for 10,000 AIC. If ordered, an audible and visual alarm activates when an output distribution circuit breaker is open or has tripped.

### (-20YR) 20 year Sealed Lead Calcium Batteries

Maintenance free battery requires no addition of water over the life of the battery. The battery cells are housed in protective, modular steel trays. Life expectancy is designed for 20-years at 77°F (25°C).

### (-12HR) 12 hourfast recharge

Battery charger upgrade option which decreases the time required to return a fully discharged battery to the fully charged state. The normal 24 hour recharge cycle is reduced to a 12 hour period.

### (-MBYP) Internal maintenance bypass switch

Internally mounted device permits maintenance personnel to easily bypass the protected equipment directly to the AC utility power. The manual make before break switch isolates the system to perform routine maintenance or servicing without interruption of utility power to the connected load.

### (-EMBP) External Maintenance bypass switch

The external maintenance bypass switch is mounted in a 20"H x 16"W x 9"D NEMA 1 separate enclosure, used to completely isolate the inverter system from the connected load and AC utility input. This option allows the system to be safely powered down for maintenance or service. The option may not be used on systems with more than one single pole output circuit breaker which must be sized for the total system output current.

### (-RMP) Remote meter panel

The panel allows monitoring of parameters and control from remote locations up to 150 feet away from the inverter system. Also, the remote panel provides a complete touch pad interface allowing the user to monitor, control and program the inverter system.

### (-RSAP) Remote summary alarm panel

Wall mountable box provides visual and audible alarms with silent switch. The panel consists of LED indicators and built in audible alarm and may be located up to 1,000 feet away from the inverter system.

### (-DCS) Summary alarm dry contacts

Form C dry contacts for remote monitoring purposes. Rated at 5 amps max. (250VAC/30VDC), the contacts will change state when any of the following alarms: High/Low Battery Charger Voltage, High/Low AC Input Voltage, Near Low Battery Voltage, Low Battery Voltage, Load Reduction Fault, High Ambient Temperature, Inverter Fault, Output Fault, Output Overload or Optional circuit breaker trip alarms, occurs. (-INVON) Inverter On Dry Contacts

### (-INVON) Inverter on drycontacts

Form C dry contacts that will change state when the system transfers to battery operation

### (-VTD) Time delay, 15 minutes (for normally off circuits)

After a return of AC utility power, delays retransfer of the inverter for up to 15 min. and continues to supply emergency power to the normally off circuits.

### (-NOFF) Normally Off output

This output circuit is dedicated for the emergency only equipment. Emergency only equipment operates during power outages and

when the system is on battery back up. This option leaves the normally off load circuits off during normal utility power conditions. A 1-pole circuit breaker is provided. For 3 phase systems, 3 pole normally off circuits are available as well.

### (-MOD) External modem

External modem device is designed to boost the signal level of the RS-232 diagnostic interface to remote monitoring locations located more than 100 feet away from the system.

### (-FAX) Internal fax modem

The internal fax modem enables the system to send a fax automatically to several pre-programmed numbers when one of the following conditions occurs: utility failure, output failure or any alarm. The Fax Modem option requires a user supplied dedicated phone line.

### (-BPR) Bypass relays

Internal bypass relays will allow overriding circuits that can be switched on/off, so in case of a power failure the emergency circuits will be supplied from the inverter system whatever the position of the switching device. Please consult factory for more details.

### (-SEIS) Seismic mounting kit

The seismic mounting kit option is designed to prevent system movement during seismic events. Heavy duty brackets are provided to secure system cabinetry to floor surfaces. Meets Zone 4 requirements.

### (-ZONEM) Zone monitoring

Allows voltage monitoring of different circuits than the standard AC utility input. When the voltage of one of these circuits drops, the inverter system will go into battery back-up operation mode. Number and voltage of the monitored circuits to be specified.

### (-RS232) Diagnostic interface

A microprocessor-based data acquisition system designed to monitor all the system parameters remotely. Monitors alarm log, event log and automatic test log. User can command the system to perform a battery test and review all system parameters. Access is through a DB9 connector and transmits at 9600 baud.

### (-BATM) Battery cycle warranty monitor

Device providing battery monitoring at string level or cell level. Please consult factory for more details.

## Light Support Power Systems Options - Control Panel & Display Functions

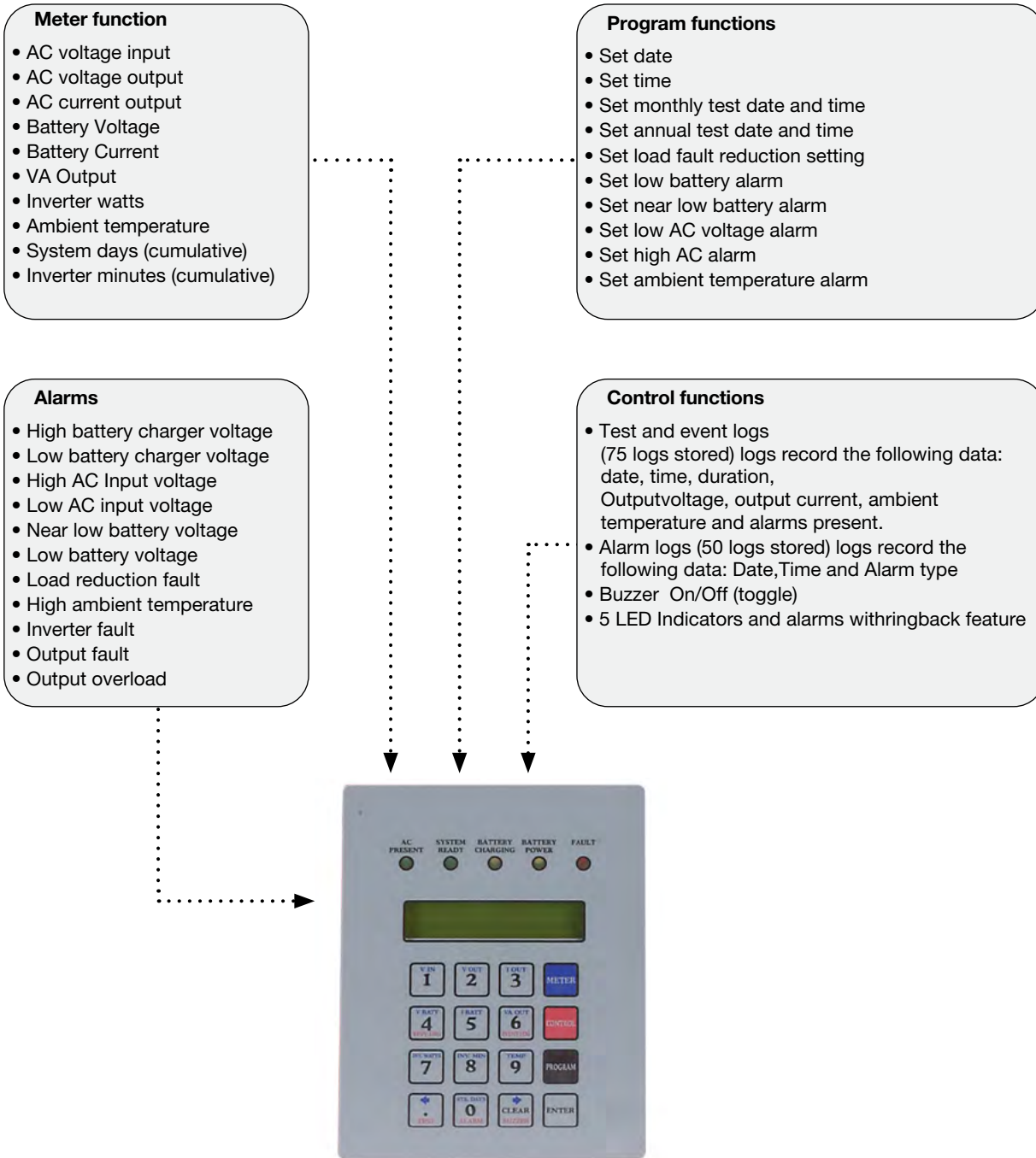

### System Testing

Systems provide one manual and two automatic test functions. Manual tests of system may be performed at any time using the control panel test key. Automatic self-diagnostic tests consist of a 5-minute monthly and 90-minute annual function (the user can program the date and time of day the test is to take place). The microprocessor automatically records the last 75 test events in its own separate test result log.

## Light Support Power Systems Options - AC Central Systems Request Data

### 1) Input voltage

Single phase (2 wire + ground)    120VAC                       208VAC                       240VAC                       277VAC   
 Three phase (4 wire + ground, Y)    120/208VAC                       277/480V   
 Three phase (3 wire + ground, Δ)    208VAC                       480VAC

### 2) Output voltage

Single phase (2 wire + ground)    120VAC                       208VAC                       277VAC   
 Single phase (3 wire + ground)    120/240V                       120/277   
 Three phase (4 wire + ground, Y)    120/208VAC                       277/480V

### 3) System capacity

KVA rating: \_\_\_\_\_ System series type \_\_\_\_\_

- a) Please consider power consumption and maximum current of the complete lamp fixture not just the lamp wattage (ie: ballasts consumption)
- b) Please consider loads power factor
- c) Even if the systems can run with 100% load, it is recommended as standard practice to use a system with a capacity at least 10% over maximum connected load

### 4) Type of loads

Incandescent                       Fluorescent                       H.I.D (metal halide, high pressure sodium, etc.)

Others \_\_\_\_\_

### 5) Mode of operation

Normally ON (24/7)                       Normally OFF (emergency only)                       Switched loads ON/OFF

- a) Please consider internal bypass relays or external override relays for switched On/Off loads.  
Each switched output circuit will require a bypass relay. Maximum 20 A per circuit.

### 6) Integrated output circuit breakers

# of CB \_\_\_\_\_ Amps \_\_\_\_\_ Voltage \_\_\_\_\_ # of poles \_\_\_\_\_ NON                       NOFF                       Trip alarm

#of CB \_\_\_\_\_ Amps \_\_\_\_\_ Voltage \_\_\_\_\_ # of poles \_\_\_\_\_ NON                       NOFF                       Trip alarm

### 7) Type of batteries (check availability for each type system)

10 yr sealed lead calcium                       20 yr sealed lead calcium

### 8) Options (refer to available options for each type system)

- 12HR- 12 hr fast recharge
- MBYP- internal bypass switch
- EMBP- external bypass switch
- RMP- remote metering panel
- RSAP- remote summary alarm panel
- DCS- dry summary alarm contacts
- INVON- inverter on dry contacts
- RS232- diagnostic interface
- WB- wall mount bracket
- NOFF – normally OFF output
- MOD- external modem
- FAX- fax modem
- BPR- bypass relays How many \_\_\_\_\_
- SEIS- seismic mounting
- ZONEM- zone monitoring
- VTD- Time delay, 15 min.
- BATM – battery cycle warranty monitor







#### LAMP DATA AND ACCESSORIES

Choose from different MR16 LED voltages and wattages to provide required illumination levels. Light levels must take into account the mounting height needed, surface reflectance, and preferred spacing for each installation. Accessories such as wire guards and mounting plates meet specific installation requirements.

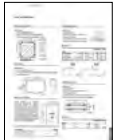
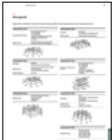

# Table of contents

## Accessories & General Information

			
<b>Lamp data</b>	<b>Unit accessories</b>	<b>Wire guards</b>	<b>National Electrical Code</b>
184	185	186-188	189-192
			
<b>Life Safety Code</b>	<b>Limited warranty</b>	<b>Product index</b>	
193-196	197	198	

## Lamp Data

### Important considerations when choosing the proper lamp

Emergency Lighting is required to provide illumination for a minimum of 90 minutes or an hour and a half during an emergency situation. Emergency Lighting lamps powered from a DC battery source must be powered by a battery that has the capacity to power all the lamps using that battery source for a minimum of 90 minutes. It is important to choose the correct lumen output lamp to meet the required illumination at the floor level on a path of egress. It is equally important to match the lamp and the battery voltages. If you do not have a battery that is the same voltage as the lamp and with enough wattage capacity to illuminate all the lamps, then the lamps will not provide adequate lumen output for 90 minutes to meet the required illumination at floor level along the path of egress.

First, match voltage. The voltage of the lamp **MUST** exactly match the voltage of the battery powering that lamp. If the voltage of the battery is lower than the voltage of the lamp, the lamp may not illuminate. If the voltage of the battery is higher than the voltage of the lamp, the lamp may “pop”.

Second, consider total wattage. The wattage of each individual lamp drawing from a battery during emergency operation, including the lamps mounted on the unit as well as all remote lamps wired to that unit, added together, **CAN NOT EXCEED** the total wattage capacity of that battery within 90 minutes of operation. A unit's battery wattage capacities are shown in the Unit Rating Chart of each particular unit.

Available lamp types are shown on the Lamp Selection Chart on the catalog page for each head style or fixture type. Lamp Selection Chart information refers to a single lamp. If you are using a double or triple lamp type head or fixture, the wattage draw of that head or fixture will be the total number of lamps used. For example, if you are using a double lamp fixture with a 12W lamp, that fixture will have a 24W draw (two lamps of 12W each, 12W + 12W = 24W total).

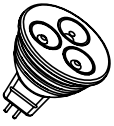
Lamp Type	Part number	Lamp suffix	Voltage	Watts	Average lumen	Total candle power (CP)	Lamp #	Bulb type
MR16 LED Lamps 	580.0097-L	LD1	6	4	199	600	24	MR16
	580.0122-L	LD2	6	5	415	1300	24	MR16
	580.0093-L	LD7	12	4	222	440	30	MR16
	580.0104-L	LD9	12	5	340	900	24	MR16
	580.0106-L	LD10	12	6	540	1800	25	MR16
	580.0098-L	LD13	24	4	223	900	24	MR16
	580.0100-L	LD14	24	6	590	1939	24	MR16
	580.0095-L	LD25	120	4	200	900	24	MR16

## Unit accessories

### Polycarbonate shields

#### VRC Series

- VRC = Vandal Resistant
- VRC-4X = NEMA-4X Vandal Resistant (including a gasket and breather vent)

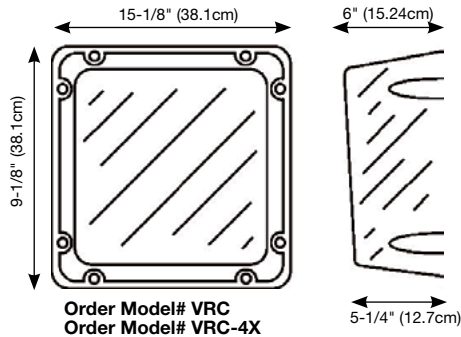

#### CPS Series

- CPS = Vandal Resistant
- CPS-4X = NEMA-4X Vandal Resistant (including a gasket and breather vent)

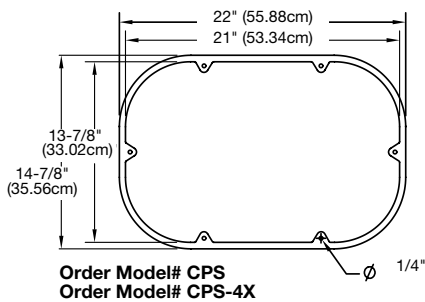

#### Remote test switch

Make testing your ceiling mounted equipment easier with the remote test switch. Compatible with 120 or 277VAC circuits, the remote test switch will interrupt the line voltage to your equipment by means of a momentary push button switch. AC on/Charge status indicator lamp assures that power is going to your emergency lighting.

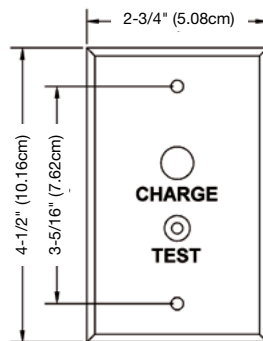

### Mounting platforms

#### MP Series

- 14 gauge steel
- Corrosion resistant undercoat
- Oven baked finish
- 1/2" retaining lip on three sides
- Keyhole slots for easy mounting



#### Dimensions

Model	Dimensions (inches)						
	a	b	c	d	e	f	g
MP-PQB (Mist)	17	7-3/4	12-1/4	16	3/4	5/16	5/8
MP-A (Gray)	17	7-3/4	12-1/4	16	3/4	5/16	5/8
MP-PQA (Mist)	16-3/8	5-3/4	10-1/4	12-1/2	7/8	5/16	7/16
MP12 (Mist white)	27-1/2	7-3/4	12-1/4	16	1-5/8	3/16	5/16

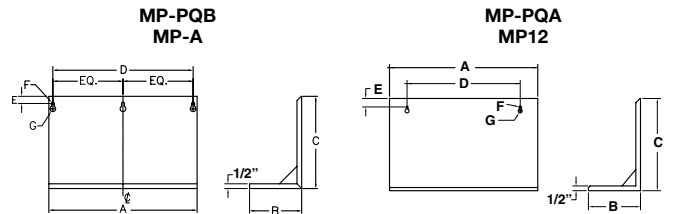

### Mounting brackets

#### MB Series

- 16 gauge steel
- Corrosion resistant undercoat
- Oven baked finish
- Supplied with rubber stand-offs for unit and machine screws to secure unit to bracket

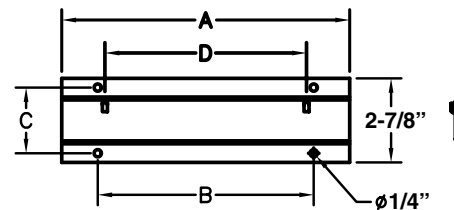

#### Dimensions

Model	Dimensions (inches)			
	a	b	c	d
MB-A	10	7-3/4	2-3/16	7
MB-B	14-1/4	11-3/4	2-3/16	12-5/8

Description	Part no.
Remote Test Switch (Chrome)	PSW
Remote Test Switch (Plastic)	PSW1

## Wire guards

Designed to increase the protection level and deter vandalism to Exit signs, Battery units and Remote fixtures

Catalog Number WG1-L	
Exit signs (wall mount)	GX, GXE Series (6" only) XD, XDN Series TX, TXE Series UX4 Series, GRANDE™ Exit Series QLX500, QLXN500 Series XT Series
Battery units	Grande™ battery unit (wall mount) MG Series (ELF3, DR1130 Heads)

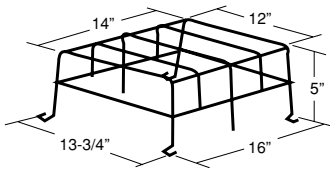

Catalog Number WG4-L	
Exit signs	QLXN2SQ (Combination Unit, Wall Mount)
Battery units	S12E5, S12E6 & S24E4 Series

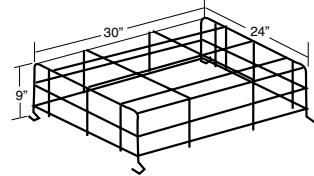

Catalog Number WG2-L	
Exit signs	Grande™ (combination unit, wall mount)
Battery units	PG & P12G Series PN & P12N Series (A cabinet)
Remote fixtures	DR 3130

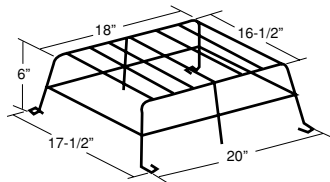

Catalog Number WG5-L	
Exit signs (ceiling & end mount)	GX, GXE Series (6" only) XD, XDN Series TX, TXE Series UX4 Series, GRANDE™ Exit Series QLX500, QLXN500 Series XT Series

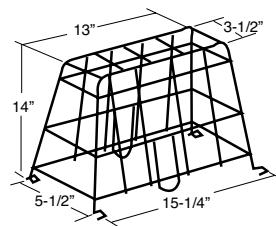

Catalog Number WG3-L	
Battery units	PN & P12N Series (B Cabinet) PQ & P12Q Series S12E4 Series

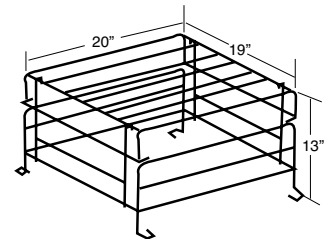

Catalog Number WG6-L	
Exit signs	UX4 (combination unit, wall mount)
Battery units	RD Series

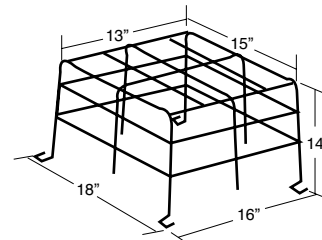

Catalog Number WG8-L	
Remote fixtures	DR1130, DR 2130; ELF3, ELF3D, ELF3T

## Wire guards

Designed to increase the protection level and deter vandalism to Exit signs, Battery units and Remote fixtures

### Catalog Number WG10-L

Battery units

LCA-2 SQ Series  
LCA-2 LED Series

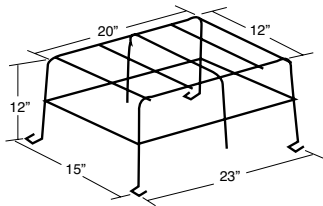

### Catalog Number WG13-L

Exit signs (wall mount)

GX, GXE Series (6" only)  
XD, XDN Series  
XL Series  
TX, TXE Series  
UX4 Series  
GRANDE™ Exit Series  
QLX500, QLXN500 Series  
XT Series

Battery units

LCA-2 SQ Series  
LCA-2 LED Series

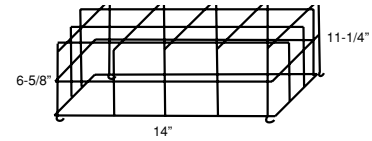

### Catalog Number WG11-L

Exit signs (wall mount)

Floor proximity recessed exit  
TX, TXE Series

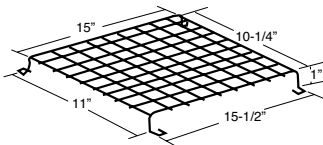

### Catalog Number WG14-L

Exit signs (ceiling mount)

GX, GXE Series (6" & 8")  
XD, XDN Series  
TX, TXE Series  
UX4 Series  
GRANDE™ Exit Series  
QLX500, QLXN500 Series

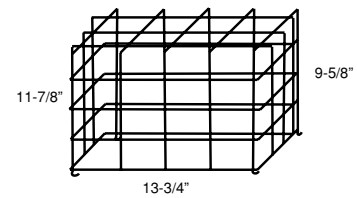

### Catalog Number WG12-L

Exit signs (wall mount)

XD, XDN Series  
TX, TXE Series  
UX4 Series,  
GRANDE™ Exit Series  
QLX500, QLXN500 Series  
XT Series

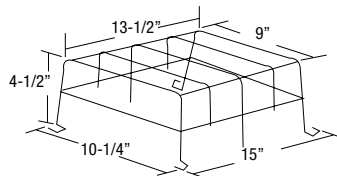

### Catalog Number WG15-L

Exit signs (wall mount)

GX, GXE Series (6" & 8")  
XD, XDN Series  
TX, TXE Series  
UX4 Series,  
GRANDE™ Exit Series  
QLX500, QLXN500 Series

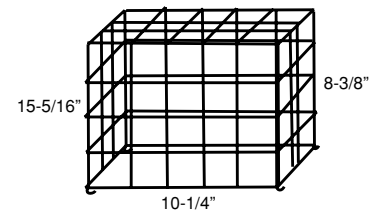

## Wire guide

### Determining Wire Size

The following information is provided to assist in designing proper emergency lighting systems effectively and economically by using the smallest permissible wire size for load circuits. When remote lighting fixtures and/or Exit Signs are connected to emergency lighting units, circuit runs must be of sufficient size to maintain a proper operating voltage to all lamps. The National Electrical Code limits voltage to drop to a maximum of 5% of nominal. The table below gives the maximum length or wire run based on systems voltage, wire gauge and total wattage on the run. To determine the maximum length of a wire run not listed, divide the value of the load in watts into the constant listed at the bottom of each row. Example, the maximum wire run for #10 wire on a 12 volt system, with a 54 watt load, is  $3397 \div 54$  or 62 feet.

Conversely, to determine the maximum load on a run of known length, divide the length into the constant. Example, a 36 foot run of #12 wire on a 6 volt systems can be loaded to,  $534 \div 36$ , or 14 watts; on #10 wire, 23 watts.

Total watts on wire run	6 volt wire size				12 volt wire size					24 volt wire size			
	#12	#10	#8	#6	#12	#10	#8	#6	#4	#12	#10	#8	#6
6	89	141	225	357	356	566	900	1431	+	1425	+	+	+
8	66	106	168	268	267	424	675	1073	1707	1068	1698	+	+
9	59	94	150	238	237	377	600	954	1517	949	1509	+	+
10	53	84	135	214	213	339	540	859	1366	854	1358	+	+
12	44	70	112	178	178	283	450	715	1138	712	1132	1801	+
16	33	53	84	134	133	212	337	536	853	534	849	1350	+
18	29	47	75	119	118	188	300	477	758	474	754	1200	1909
24	22	35	56	89	89	141	225	357	569	356	566	900	1431
25	21	33	54	85	85	135	216	343	546	341	543	864	1374
27	19	31	50	79	79	125	200	318	505	316	503	800	1272
30	17	28	45	71	71	113	180	286	455	284	452	720	1145
36	14	23	37	59	59	94	150	238	379	237	377	600	954
42	12	20	32	51	50	80	128	204	325	203	323	514	818
45	11	18	30	47	47	75	120	190	303	189	301	480	763
48	11	17	28	44	44	70	112	178	284	178	283	450	715
50	10	16	27	42	42	67	108	171	273	170	271	432	687
75	7	11	18	28	28	45	72	114	182	113	181	288	458
100	5	8	13	21	21	33	54	85	136	85	135	216	343
150	-	5	9	14	14	22	36	57	91	56	90	144	229
200	-	-	6	10	10	16	27	42	68	42	67	108	171
250	-	-	5	8	8	13	21	34	54	34	54	86	137
300	-	-	-	7	7	11	18	28	45	28	45	72	114
400	-	-	-	5	5	8	13	21	34	21	33	54	85
500	-	-	-	-	-	6	10	17	27	17	27	43	68
<b>Constant</b>	534	849	1350	2148	2137	3397	5403	8590	13660	8548	13588	21613	34363

Wiring distance in feet (Maximum voltage drop 5%)

### Longer Wire Runs

The wiring distances give the maximum length of a battery circuit, assuming that the entire load is concentrated at the end of the circuit. If loads are uniformly spaced along the circuit path (equal watts, equal distances), the lengths in the table may be increased, based on number of fixtures on a given circuit, by means of the chart and formula below.

Number of Fixtures	2	3	4	5	6	N
<b>Multiply By Feet</b>	1.33	1.5	1.6	1.67	1.71	$2n/(n+1)$

For example, a 36 foot long, 6 volt circuit has (3) 9 watt heads spaced 12 feet apart. According to the wire run table, # 8 wire must be used (at 50 feet for a 5% voltage drop.) but, by multiplying the 31 feet for #10 wire by 1.5, a 46 1/2 foot wire run is acceptable, so #10 wire may be used and still meet the 5% voltage drop limitation.

Note: According to the National Electrical Code, Article 720-Y, the smallest permissible wire size for systems under 50 volts is the #12 wire gauge.

## National Electrical Code

### ARTICLE 700 – EMERGENCY SYSTEMS

#### I. General

700.1. Scope. The provisions of this article apply to the electrical safety of the installation, operation, and maintenance of emergency systems consisting of circuits and equipment intended to supply, distribute, and control electricity for illumination or power, or both, to required facilities when the normal electrical supply or system is interrupted.

(FPN No. 1): For further information regarding wiring and installation of emergency systems in health care facilities, see Article 517.

(FPN No. 2): For further information regarding performance and maintenance of emergency systems in health care facilities, see Standard for Health Care Facilities, NFPA 99-2012.

(FPN No. 3): Emergency systems are generally installed in places of assembly where artificial illumination is required for safe exiting and for panic control in buildings subject to occupancy by large numbers of persons, such as hotels, theaters, sports arenas, health care facilities, and similar institutions. Emergency systems may also provide power for such functions as ventilation where essential to maintain life, fire detection and alarm systems, elevators, fire pumps, public safety communications systems, industrial processes where current interruption would produce serious life safety or health hazards, and similar functions.

(FPN No. 4): For specification of locations where emergency lighting is considered essential to life safety, see Life Safety Code, NFPA 101-2012.

(FPN No. 5): For further information regarding performance of emergency and standby power systems, see Standard for Emergency and Standby Power Systems, NFPA 110-1999.

#### 700.2. Definitions

**Emergency Systems.** Those systems legally required and classed as emergency by municipal, state, federal or other codes, or by any governmental agency having jurisdiction. These systems are intended to automatically supply illumination, power or both, to designated areas and equipment in the event of failure of the normal supply or in the event of accident to elements of a system intended to supply, distribute, and control power and illumination essential for safety to human life.

Informational Note: Emergency systems are generally installed in places of assembly where artificial illumination is required for safe exiting and for panic control in buildings subject to occupancy by large numbers of persons, such as hotels, theatres, sports, arenas, health care facilities, and similar institutions. Emergency systems may also provide power for such functions as ventilation where essential to maintain life, fire detection and alarm systems, elevators, fire pumps, public safety communications systems, industrial processes where current interruption would produce serious life safety or health hazards, and similar functions.

**Relay automatic Load Control.** A device used to set normally dimmed or normally-off switched emergency lighting equipment to full power illumination levels in the event of a loss of the normal supply by bypassing the dimming/switching controls, and to return the emergency lighting equipment to normal status when the device senses the normal supply has been restored.

Informational Note: See ANSI/UL 924, Emergency Lighting and Power Equipment, for the requirements covering automatic load control relays.

#### 700.3. Tests and Maintenance.

(A) **Conduct or Witness Test.** The authority having jurisdiction shall conduct or witness a test of the complete system upon installation and periodically afterward.

(B) **Tested Periodically.** Systems shall be tested periodically on a schedule acceptable to the authority having jurisdiction to ensure the systems are maintained in proper operating condition.

(C) **Battery Systems Maintenance.** Where battery systems or unit equipment are involved, including batteries used for starting, control, or ignition in auxiliary engines, the authority having jurisdiction shall require periodic maintenance.

(D) **Written Record.** A written record shall be kept of such tests and maintenance.

(E) **Testing Under Load.** Means for testing all emergency lighting and power systems during maximum anticipated load conditions shall be provided.

For information on testing and maintenance of emergency power supply systems (EPSSs), see NFPA 110-2013, Standard for Emergency and Standby Power Systems.

#### 700.4. Capacity.

(A) **Capacity and Rating.** An emergency system shall have adequate capacity and rating for all loads to be operated simultaneously. The emergency system equipment shall be suitable for the maximum available fault current at its terminals.

(B) **Selective Load Pickup, Load Shedding, and Peak Load Shaving.** The alternate power source shall be permitted to supply emergency, legally required standby, and optional standby system loads where the source has adequate capacity or where automatic selective load pickup and load shedding is provided as needed to ensure adequate power to (1) the emergency circuits; (2) the legally required standby circuits; and (3) the optional standby circuits, in that order of priority.

The alternate power source shall be permitted to be used for peak load shaving, provided the above conditions are met.

Peak load shaving operation shall be permitted for satisfying the test requirement of Section 700.3(B), provided all other conditions of Section 700.3 are met. A portable or temporary alternate source shall be available whenever the emergency generator is out of service for major maintenance or repair.

#### 700.5. Transfer Equipment.

(A) **General.** Transfer equipment, including automatic transfer switches, shall be automatic and identified for emergency use and approved by the authority having jurisdiction. Transfer equipment shall be designed and installed to prevent the inadvertent interconnection of normal and emergency sources of supply in any operation of the transfer equipment. Transfer equipment and electric power production systems installed to permit operation in parallel with the normal source shall meet the requirements of article 705.

(B) **Bypass Isolation Switches.** Means shall be permitted to bypass and isolate the transfer equipment. Where bypass isolation switches are used, inadvertent parallel operation shall be avoided.

(C) **Automatic transfer switches** shall be electrically operated and mechanically held. Automatic transfer switches, rated 1000 VAC and below, shall be listed for emergency system use.

(D) **Use.** Transfer equipment shall supply only emergency loads.

**700-6. Signals.** Audible and visual signal devices shall be provided, where practicable, for the following purposes described in 700.6(A) through (D).

(A) **Derangement.** To indicate derangement of the emergency source.

(B) **Carrying Load.** To indicate that the battery is carrying load.

(C) **Not Functioning.** To indicate that the battery charger is not functioning.

(D) **Ground Fault.** To indicate a ground fault in solidly grounded wye emergency systems of more than 150 volts to ground and circuit protective devices rated 1000 amperes or more. The sensor for the ground-fault signal devices shall be located at, or ahead of, the

## National Electrical Code

main system disconnecting means for the emergency source, and the maximum setting of the signal devices shall be for a ground-fault current of 1200 amperes. Instructions on the course of action to be taken in event of indicated ground fault shall be located at or near the sensor location.

Informational Note: For signals for generator sets, see NFPA 110-2013, Standard for Emergency and Standby Power Systems

### 700.7. Signs.

**(A) Emergency Sources.** A sign shall be placed at the service entrance equipment indicating type and location of on-site emergency power sources. Exception: A sign shall not be required for individual unit equipment as specified in Section 700-12(F).

**(B) Grounding.** Where removal of a grounding or bonding connection in the normal power source equipment interrupts the grounding electrode conductor connection to the alternate power source(s) grounded conductor, a warning sign shall be installed at the normal power source equipment stating:

#### WARNING

**SHOCK HAZARD EXISTS IF GROUNDING ELECTRODE CONDUCTOR OR BONDING JUMPER CONNECTION IN THIS EQUIPMENT IS REMOVED WHILE ALTERNATE SOURCE(S) IS ENERGIZED. The warning sign(s) or label(s) shall comply with 110.21(B).**

### 700.8

**Emergency Sources.** A listed SPD shall be installed in or on all emergency systems switchboards and panelboards.

## II. CIRCUIT WIRING

### 700-10. Wiring, Emergency System.

**(A) Identification.** All boxes and enclosures (including transfer switches, generators, and power panels) for emergency circuits shall be permanently marked so they will be readily identified as a component of an emergency circuit or system.

**(B) Wiring.** Wiring of two or more emergency circuits supplied from the same source shall be permitted in the same raceway, cable, box, or cabinet. Wiring from an emergency source distribution overcurrent protection to emergency loads shall be kept entirely independent of all other wiring and equipment, unless otherwise permitted in 700.10(B) (1) through (5):

**(1)** Wiring from the normal power source located in transfer equipment enclosures.

**(2)** Wiring supplied from two sources in exit or emergency luminaires

**(3)** Wiring from two sources in a listed load control relay supplying exit or emergency luminaires, or in a common junction box, attached to exit or emergency luminaires

**(4)** Wiring within a common junction box attached to unit equipment, containing only the branch circuit supplying the unit equipment and the emergency circuit supplied by the unit equipment.

**(5)** Wiring from an emergency source to supply emergency and other loads in accordance with 700.10(B)(5)a, b, c, and d as follows:

a. Separate vertical switchgear sections or separate vertical switchboard sections, with or without a common bus, or individual disconnects mounted in separate enclosures shall be used to separate emergency loads from all other loads.

b. The common bus of separate sections of the switchgear, separate sections of the switchboard, or the individual enclosures shall be permitted to be supplied by single or multiple feeders without overcurrent protection at the source.

Exception to (5)b: Overcurrent protection shall be permitted at the source or for the equipment, provided the overcurrent protection complies with the requirements of 700.28.

c. Emergency required and optional standby circuits shall not originate from the same vertical switchgear section, panel board enclosure, or individual disconnect enclosure as emergency circuits.

d. It shall be permissible to utilize single or multiple feeders to supply distribution equipment between an emergency source and the point where the emergency loads are separated from all other loads.

**(C) Wiring Design and Location.** Emergency wiring circuits shall be designed and located to minimize the hazards that might cause failure due to flooding, fire, icing, vandalism, and other adverse conditions.

**(D) Fire Protection.** Emergency systems shall meet the following additional requirements (D)(1) through (D)(3) in assembly occupancies for not less than 1000 persons or in buildings above 23 m (75 ft) in height.

**(1) Feeder-circuit wiring** shall meet one of the following conditions:

(1) Be installed in spaces or areas that are fully protected by an approved automatic fire suppression system.

(2) Be listed electrical circuit protective system with a minimum 2-hour fire rating Informational note: UL guide information for electrical circuit protective systems (FHIT) contains information on proper installation requirements to maintain the fire rating

(3) Be protected by a listed thermal barrier system for electrical system components with a minimum 2-hour fire rating.

(4) Be protected by a listed fire-rated assembly that has a minimum fire rating of 2 hours and contains only emergency wiring circuits

(5) Be encased in a minimum of 50 mm (2 in) of concrete

**(2) Feeder-Circuit Equipment.** Equipment for feeder circuits (transfer switches, transformers, panel boards) shall be either located in spaces fully protected by approved automatic fire suppression systems (including sprinklers and carbon dioxide systems) or in spaces with a 2-hour fire resistance rating.

**(3) Generator Control Wiring.** Control conductors installed between the transfer equipment and the emergency generator shall be kept entirely independent of all other wiring and shall meet the conditions of 700.10(D) (1)

## III. SOURCES OF POWER

**700.12. General Requirements.** Current supply shall be such that, in the event of failure of the normal supply to, or within, the building or group of buildings concerned, emergency lighting, emergency power, or both will be available within the time required for the application but not to exceed 10 seconds. The supply system for emergency purposes, in addition to the normal services to the building and meeting the general requirements of this section, shall be one or more of the types of systems described in 700.12(A) through (D) below. Unit equipment in accordance with Section 700.12(E) shall satisfy the applicable requirements of this article.

In selecting an emergency source of power, consideration shall be given to the occupancy and the type of service to be rendered, whether of minimum duration, as for evacuation of a theater, or longer duration, as for supplying emergency power and lighting due to an indefinite period of current failure from trouble either inside or outside the building.

Equipment shall be designed and located to minimize the hazards that might cause complete failure due to flooding, fires, icing, and vandalism. Equipment for sources of power as described in Sections 700.12(A) through (E) where located within assembly occupancies for greater than 1000 persons or in buildings above 23 m (75 ft) in height with any of the following occupancy classes: assembly, educational, residential, detention and correctional, business, and mercantile, shall be installed either in spaces fully protected by approved automatic fire suppression systems (sprinklers, carbon dioxide systems, and so forth), or in spaces with a 1-hour fire rating.

Informational note No. 1: For definition of Occupancy Classification, see Section 6.1 of NFPA 101-2012, Life Safety Code.



## National Electrical Code

Informational note No. 2: For further information, see ANSI/IEEE 493-2007, Recommended Practice for the Design of Reliable Industrial and Commercial Power Systems.

**(A) Storage Battery.** Storage batteries used as source of power for emergency systems shall be of suitable rating and capacity to supply and maintain the total load for a period of 1 1/2 hours minimum, without the voltage applied to the load falling below 87 1/2 percent of normal. Batteries, whether of the acid or alkali type, shall be designed and constructed to meet the requirements of emergency service and shall be compatible with the charger for that particular installation.

For a sealed battery, the container shall not be required to be transparent. However, for the lead acid battery that requires water additions, transparent or translucent containers shall be furnished.

Automotive-type batteries shall not be used.

An automatic battery charging means shall be provided.

### **(B) Generator Set.**

(1) **Prime Mover-Driven.** For a generator set driven by a prime mover acceptable to the authority having jurisdiction and sized in accordance with Section 700-4. Means shall be provided for automatically starting the prime mover on failure of the normal service and for automatic transfer and operation of all required electrical circuits. A time-delay feature permitting a 15-minute setting shall be provided to avoid retransfer in case of short-time reestablishment of the normal source.

(2) **Internal Combustion Engines as Prime Movers.** Where internal combustion engines are used as the prime mover an on-site fuel supply shall be provided with an on-premise fuel supply sufficient for not less than 2 hours full-demand operation of the system. Where power is needed for the operation of the fuel transfer pumps to deliver fuel to a generator set dry tank, this pump shall be connected to the emergency power system.

(3) **Dual Supplies.** Prime movers shall not be solely dependent upon a public utility gas system for their fuel supply or municipal water supply for their cooling systems. Means shall be provided for automatically transferring from one fuel supply to another where dual fuel supplies are used.

Exception: Where acceptable to the authority having jurisdiction, the use of other than on-site fuels shall be permitted where there is a low probability of a simultaneous failure of both the off-site fuel delivery system and power from the outside electrical utility company.

(4) **Where a storage battery** is used for control or signal power, or as the means of starting the prime mover, it shall be suitable for the purpose and shall be equipped with an automatic charging means independent of the generator set. Where the battery charger is required for the operation of the generator set, it shall be connected to the emergency system. Where power is required for the operation of dampers used to ventilate the generator set, the dampers shall be connected to the emergency system.

(5) **Auxiliary Power Supply.** Generator sets that require more than 10 seconds to develop power shall be permitted is an auxiliary power supply energizes the emergency system until the generator can pick up the load.

(6) **Outdoor Generator Sets.** Where an outdoor housed generator set is equipped with a readily accessible disconnecting means in accordance with 445.18, and the disconnecting means is located within sight of the building or structure supplied, an additional disconnecting means shall not be required where ungrounded conductors serve or pass through the building or structure. Where the generator supply conductors terminate at a disconnecting means in or on a building or structure, the disconnecting means shall meet the requirements of 225.36.

Exception: For installations under single management where conditions of maintenance and supervision ensure that only qualified persons will monitor and service the installation and where documented safe switching procedures are established and maintained for disconnection,

the generator set disconnecting means shall not be required to be located within sight of the building of structure served.

**(C) Uninterruptible Power Supplies.** Uninterruptible power supplies used to provide power for emergency systems shall comply with the applicable provisions of Sections 700-12(A) and (B).

**(D) Separate Service.** Where acceptable to the authority having jurisdiction as suitable for use as an emergency source of power, an additional service shall be permitted. This service shall be in accordance with the applicable provisions of Article 230 and following additional requirements.

(1) Separate overhead service conductors, service drops, underground service conductors, or service laterals shall be installed.

(2) The service conductors for the separate service shall be installed sufficiently remote electrically and physically from any other service conductors to minimize the possibility of simultaneous interruption of supply.

**(E) Fuel Cell System.** Fuel Cell Systems used as a source of power for emergency systems shall be of suitable rating and capacity to supply and maintain the total load for not less than 2 hours of full demand operation.

### **(F) Unit Equipment**

**(1) Components of Unit Equipment.** Individual unit equipment for emergency illumination shall consist of the following:

(1) A rechargeable battery

(2) A battery charging means

(3) Provisions for one or more lamps mounted on the equipment, or shall be permitted to have terminals for remote lamps, or both and

(4) A relaying device arranged to energize the lamps automatically upon failure of the supply to the unit equipment.

**(2) Installation of Unit Equipment.** Unit equipment shall be installed in accordance with 700.12(F)(2)(1) through (6).

(1) The batteries shall be of suitable rating and capacity to supply and maintain at not less than 87-1/2 percent of the nominal battery voltage for the total lamp load associated with the unit for a period of at least 1-1/2 hours, or the unit equipment shall supply and maintain not less than 60 percent of the initial emergency illumination for a period of at least 1-1/2 hours. Storage batteries, whether of the acid or alkali type, shall be designed and constructed to meet the requirements of emergency service.

(2) Unit equipment shall be permanently fixed in place (i.e., not portable) and shall have all wiring to each unit installed in accordance with the requirements of any of the wiring methods in Chapter 3. Flexible cord and plug connection shall be permitted, provided that the cord does not exceed 3 ft (900 mm) in length.

(3) The branch circuit feeding the unit equipment shall be the same branch circuit as that serving the normal lighting in the area and connected ahead of any local switches.

Exception : In a separate and uninterrupted area supplied by a minimum of three normal lighting circuits, a separate branch circuit for unit equipment shall be permitted if it originates from the same panelboard as that of the normal lighting circuits and is provided with a lock-on feature.

(4) The branch circuit that feeds unit equipment shall be clearly identified at the distribution panel.

(5) Emergency luminaire's (illumination fixtures) that obtain power from a unit equipment and are not part of the unit equipment shall be wired to the unit equipment as required by Section 700-10 and by one of the wiring methods of Chapter 3.

## National Electrical Code

- (6) Remote heads providing lighting for the exterior of an exit door shall be permitted to be supplied by the unit equipment serving the area immediately inside the exit door

### IV. Emergency System Circuits for Lighting and Power

**700.15. Loads on Emergency Branch Circuits.** No appliances and no lamps, other than those specified as required for emergency use, shall be supplied by emergency lighting circuits.

**700.16. Emergency illumination.** Emergency illumination shall include all required means of egress lighting, illuminated exit signs, and all other lights specified as necessary to provide required illumination.

Emergency lighting systems shall be designed and installed so that the failure of any individual lighting element, such as the burning out of a light bulb, cannot leave in total darkness any space that requires emergency illumination.

Where high-intensity discharge lighting such as high- and low-pressure sodium mercury vapor, and metal halide is used as the sole source of normal illumination, the emergency lighting system shall be required to operate until normal illumination has been restored.

Where an emergency system is installed, emergency illumination shall be provided in the area of the disconnecting means required by 225.31 and 230.70, as applicable, where the disconnecting means are installed indoors.

Exception: Where alternative means that ensure the emergency lighting illumination level is maintained shall be permitted.

**700.17. Branch Circuits for Emergency Lighting.** Branch circuits that supply emergency lighting shall be installed to provide service from a source complying with Section 700-12 when the normal supply for lighting is interrupted. Such installations shall provide either one of the following:

(1) An emergency lighting supply, independent of the normal lighting supply, with provisions for automatically transferring the emergency lights upon the event of failure of the normal lighting branch circuit

(2) Two or more branch circuits supplied from separate and complete systems with independent power sources. One of the two power sources and systems shall be part of the emergency system and the other shall be permitted to be part of the normal power source and system. Each system shall provide sufficient power for emergency lighting purposes.

Unless both systems are used for regular lighting purposes and are both kept lighted, means shall be provided for automatically energizing either system upon failure of the other. Either or both systems shall be permitted to be a part of the general lighting of the protected occupancy if circuits supplying lights for emergency illumination are installed in accordance with other sections of this article.

**700.18. Circuits for Emergency Power.** For branch circuits that supply equipment classed as emergency, there shall be an emergency supply source to which the load will be transferred automatically upon the failure of the normal supply.

**700.19. Multiwire Branch Circuits.** The branch circuit serving emergency lighting and power circuits shall not be part of a multiwire branch circuit.

### V. CONTROL—EMERGENCY LIGHTING CIRCUITS

**700.20. Switch Requirements.** The switch or switches installed in emergency lighting circuits shall be arranged so that only authorized persons will have control of emergency lighting.

Exception No. 1: Where two or more single-throw switches are connected in parallel to control a single circuit, at least one of these switches shall be accessible only to authorized persons.

Exception No. 2: Additional switches that act only to put emergency lights into operation but not disconnect them shall be permissible.

Switches connected in series or 3- and 4-way switches shall not be used.

**700.21. Switch Location.** All manual switches for controlling emergency circuits shall be in locations convenient to authorized persons responsible for their actuation. In facilities covered by Articles 518 and 520, a switch for controlling emergency lighting systems shall be located in the lobby or at a place conveniently accessible thereto.

In no case shall a control switch for emergency lighting be placed in a motion-picture projection booth or on a stage or platform.

Exception: Where multiple switches are provided, one such switch shall be permitted in such locations where arranged so that it can energize the circuit only, but cannot deenergize the circuit.

**700.22. Exterior Lights.** Those lights on the exterior of a building that are not required for illumination when there is sufficient daylight shall be permitted to be controlled by an automatic light-actuated device.

**700.23 Dimmer and Relay Systems.** A dimmer or relay system containing more than one dimmer or relay and listed for use in emergency systems shall be permitted to be used as a control device for energizing emergency lighting circuits. Upon failure of normal power, the dimmer or relay system shall be permitted to selectively energize only those branch circuits required to provide minimum emergency illumination. All branch circuits supplied by the dimmer or relay system cabinet shall comply with the wiring methods of Article 700.

**700.24 Directly Controlled Luminaires.** Where emergency illumination is provided by one or more directly controlled luminaires that respond to an external control input to bypass normal control upon loss of normal power, such luminaires and external bypass controls shall be individually listed for use in emergency systems.

**700.25 Automatic Load Control Relay.** If an emergency lighting load is automatically energized upon loss of the normal supply, a listed automatic load control relay shall be permitted to energize the load. The load control relay shall not be used as transfer equipment.

### VI. OVERCURRENT PROTECTION

**700-26. Accessibility.** The branch-circuit overcurrent devices in emergency circuits shall be accessible to authorized persons only.

**700-27. Ground-Fault Protection of Equipment.** The alternate source for emergency systems shall not be required to have ground-fault protection of equipment with automatic disconnecting means. Ground-fault indication of the emergency source shall be provided in accordance with 700.6(D) if ground-fault protection of equipment with automatic disconnecting means is not provided. Exception: Selective coordination shall not be required between two overcurrent devices located in series if no loads are connected in parallel with the downstream device.

National Electrical Code® 2014 National Electrical Code® is a registered trademark of the National Fire Protection Association

## Life Safety Code

### 7.8 ILLUMINATION OF MEANS OF EGRESS.

#### 7.8.1 General.

**7.8.1.1\*** Illumination of means of egress shall be provided in accordance with Section 7.8 for every building and structure where required in Chapters 11 through 43. For the purposes of this requirement, exit access shall include only designated stairs, aisles, corridors, ramps, escalators, and passageways leading to an exit. For the purposes of this requirement, exit discharge shall include only designated stairs, aisles, corridors, ramps, escalators, walkways, and exit passageways leading to a public way.

**7.8.1.2** Illumination of means of egress shall be continuous during the time that the conditions of occupancy require that the means of egress be available for use, unless otherwise provided in 7.8.1.2.2.

**7.8.1.2.1** Artificial lighting shall be employed at such locations and for such periods of time as are necessary to maintain the illumination to the minimum criteria values herein specified.

**7.8.1.2.2** Unless prohibited by Chapters 11 through 43, automatic lighting control devices shall be permitted to temporarily turn off the illumination within the means of egress, provided that each lighting control device complies with all of the following:

- (1) In new installations, the lighting control device is listed.
- (2) The lighting control device is equipped to automatically energize the controlled lights upon loss of normal power and is evaluated for this purpose.
- (3) Illumination timers are provided and are set for a minimum 15-minute duration.
- (4) The lighting control device is activated by any occupant movement in the area served by the lighting units.
- (5) In new installations, the lighting control device is activated by activation of the building fire alarm system, if provided.
- (6) The lighting control device does not turn off any lights relied upon for activation of photoluminescent exit signs or path markers.
- (7) The lighting control device does not turn off any battery equipped emergency luminaires, unit equipment, or exit signs.

**7.8.1.2.3\*** Energy-saving sensors, switches, timers, or controllers shall be approved and shall not compromise the continuity of illumination of the means of egress required by 7.8.1.2.

**7.8.1.3\*** The floors and other walking surfaces within an exit and within the portions of the exit access and exit discharge designated in 7.8.1.1 shall be illuminated as follows:

- (1) During conditions of stair use, the minimum illumination for new stairs shall be at least 10 ft-candle (108 lux), measured at the walking surfaces.
- (2) The minimum illumination for floors and other walking surfaces, other than new stairs during conditions of stair use, shall be to values of at least 1 ft-candle (10.8 lux), measured at the floor.
- (3) In assembly occupancies, the illumination of the walking surfaces of exit access shall be at least 0.2 ft-candle (2.2 lux) during periods of performances or projections involving directed light.
- (4) \*The minimum illumination requirements shall not apply where operations or processes require low lighting levels.

**7.8.1.4\*** Required illumination shall be arranged so that the failure of any single lighting unit does not result in an illumination level of less than 0.2 ft-candle (2.2 lux) in any designated area.

**7.8.1.5** The equipment or units installed to meet the requirements of Section 7.10 also shall be permitted to serve the function of illumination

of means of egress, provided that all requirements of Section 7.8 for such illumination are met.

#### 7.8.2 Sources of Illumination.

**7.8.2.1\*** Illumination of means of egress shall be from a source considered reliable by the authority having jurisdiction.

**7.8.2.2** Battery-operated electric lights and other types of portable lamps or lanterns shall not be used for primary illumination of means of egress. Battery-operated electric lights shall be permitted to be used as an emergency source to the extent permitted under Section 7.9.

### 7.9 EMERGENCY LIGHTING.

#### 7.9.1 General.

**7.9.1.1\*** Emergency lighting facilities for means of egress shall be provided in accordance with Section 7.9 for the following:

- (1) Buildings or structures where required in Chapters 11 through 43
- (2) Underground and limited access structures as addressed in Section 11.7
- (3) High-rise buildings as required by other sections of this Code
- (4) Doors equipped with delayed-egress locks
- (5) Stair shafts and vestibules of smokeproof enclosures, for which the following also apply:
  - (a) The stair shaft and vestibule shall be permitted to include a standby generator that is installed for the smokeproof enclosure mechanical ventilation equipment.
  - (b) The standby generator shall be permitted to be used for the stair shaft and vestibule emergency lighting power supply.
- (6) New access-controlled egress doors in accordance with 7.2.1.6.2.

**7.9.1.2** For the purposes of 7.9.1.1, exit access shall include only designated stairs, aisles, corridors, ramps, escalators, and passageways leading to an exit. For the purposes of 7.9.1.1, exit discharge shall include only designated stairs, ramps, aisles, walkways, and escalators leading to a public way.

**7.9.1.3** Where maintenance of illumination depends on changing from one energy source to another, a delay of not more than 10 seconds shall be permitted.

#### 7.9.2 Performance of System.

**7.9.2.1** Emergency illumination shall be provided for a minimum of 1-1/2 hours in the event of failure of normal lighting.

**7.9.2.1.1** Emergency lighting facilities shall be arranged to provide initial illumination that is not less than an average of 1 ft-candle (10.8 lux) and, at any point, not less than 0.1 ft-candle (1.1 lux), measured along the path of egress at floor level.

**7.9.2.1.2** Illumination levels shall be permitted to decline to not less than an average of 0.6 ft-candle (6.5 lux) and, at any point, not less than 0.06 ft-candle (0.65 lux) at the end of 1-1/2 hours.

**7.9.2.1.3** The maximum-to-minimum illumination shall not exceed a ratio of 40 to 1.

**7.9.2.3** Emergency lighting facilities shall be arranged to provide initial illumination that is not less than an average of 1 ft-candle (10.8 lux) and, at any point, not less than 0.1 ft-candle (1.1 lux), measured along the path of egress at floor level. Illumination levels shall be permitted to decline to not less than an average of 0.6 ft-candle (6.5 lux) and, at any point, not less than 0.06 ft-candle (0.65 lux) at the

## Life Safety Code

end of 1 1/2 hours. A maximum-to-minimum illumination uniformity ratio of 40 to 1 shall not be exceeded.

**7.9.2.2** New emergency power systems for emergency lighting shall be at least Type 10, Class 1.5, Level 1, in accordance with NFPA 110, Standard for Emergency and Standby Power Systems..

**7.9.2.3\*** The emergency lighting system shall be arranged to provide the required illumination automatically in the event of any interruption of normal lighting due to any of the following:

- (1) Failure of a public utility or other outside electrical power supply
- (2) Opening of a circuit breaker or fuse
- (3) Manual act(s), including accidental opening of a switch controlling normal lighting facilities

**7.9.2.4** Emergency generators providing power to emergency lighting systems shall be installed, tested, and maintained in accordance with NFPA 110, Standard for Emergency and Standby Power Systems. Stored electrical energy systems, where required in this Code, other than battery systems for emergency luminaires in accordance with 7.9.2.5, shall be installed and tested in accordance with NFPA 111, Standard on Stored Electrical Energy Emergency and Standby Power Systems.

**7.9.2.5** Unit equipment and battery systems for emergency luminaires shall be listed to ANSI/UL 924, Standard for Emergency Lighting and Power Equipment.

**7.9.2.6\*** Existing battery-operated emergency lights shall use only reliable types of rechargeable batteries provided with suitable facilities for maintaining them in properly charged condition. Batteries used in such lights or units shall be approved for their intended use and shall comply with NFPA 70, National Electrical Code.

**7.9.2.7** The emergency lighting system shall be either continuously in operation or shall be capable of repeated automatic operation without manual intervention.

### 7.9.3 Periodic Testing of Emergency Lighting Equipment.

**7.9.3.1** Required emergency lighting systems shall be tested in accordance with one of the three options offered by 7.9.3.1.1, 7.9.3.1.2, or 7.9.3.1.3.

**7.9.3.1.1** Testing of required emergency lighting systems shall be permitted to be conducted as follows:

- (1) Functional testing shall be conducted monthly, with a minimum of 3 weeks and a maximum of 5 weeks between tests, for not less than 30 seconds, except as otherwise permitted by 7.9.3.1.1(2).
- (2)\* The test interval shall be permitted to be extended beyond 30 days with the approval of the authority having jurisdiction.
- (3) Functional testing shall be conducted annually for a minimum of 1-1/2 hours if the emergency lighting system is battery powered.
- (4) The emergency lighting equipment shall be fully operational for the duration of the tests required by 7.9.3.1.1(1) and (3).
- (5) Written records of visual inspections and tests shall be kept by the owner for inspection by the authority having jurisdiction.

**7.9.3.1.2** Testing of required emergency lighting systems shall be permitted to be conducted as follows:

- (1) Self-testing/self-diagnostic battery-operated emergency lighting equipment shall be provided.
- (2) Not less than once every 30 days, self-testing/self-diagnostic battery-operated emergency lighting equipment shall automatically perform a test with a duration of a minimum of 30 seconds and a diagnostic routine.

(3) Self-testing/self-diagnostic battery-operated emergency lighting equipment shall indicate failures by a status indicator.

(4) A visual inspection shall be performed at intervals not exceeding 30 days.

(5) Functional testing shall be conducted annually for a minimum of 1 1/2 hours.

(6) Self-testing/self-diagnostic battery-operated emergency lighting equipment shall be fully operational for the duration of the 1 1/2-hour test.

(7) Written records of visual inspections and tests shall be kept by the owner for inspection by the authority having jurisdiction.

**7.9.3.1.3** Testing of required emergency lighting systems shall be permitted to be conducted as follows:

(1) Computer-based, self-testing/self-diagnostic battery-operated emergency lighting equipment shall be provided.

(2) Not less than once every 30 days, emergency lighting equipment shall automatically perform a test with a duration of a minimum of 30 seconds and a diagnostic routine.

(3) The emergency lighting equipment shall automatically perform annually a test for a minimum of 1 1/2 hours.

(4) The emergency lighting equipment shall be fully operational for the duration of the tests required by 7.9.3.1.3(2) and (3).

(5) The computer-based system shall be capable of providing a report of the history of tests and failures at all times.

## 7.10 MARKING OF MEANS OF EGRESS.

### 7.10.1 General.

**7.10.1.1** Where Required. Means of egress shall be marked in accordance with Section 7.10 where required in Chapters 11 through 43.

### 7.10.1.2 Exits.

**7.10.1.2.1\*** Exits, other than main exterior exit doors that obviously and clearly are identifiable as exits, shall be marked by an approved sign that is readily visible from any direction of exit access.

**7.10.1.2.2\*** Horizontal components of the egress path within an exit enclosure shall be marked by approved exit or directional Exit Signs where the continuation of the egress path is not obvious.

**7.10.1.3 Exit Door Tactile Signage.** Tactile signage shall be provided to meet all of the following criteria, unless otherwise provided in 7.10.1.4:

- (1) Tactile signage shall be located at each exit door requiring an Exit Sign.
- (2) Tactile signage shall read as follows: EXIT.
- (3) Tactile signage shall comply with ICC/ANSI A117.1, American National Standard for Accessible and Usable Buildings and Facilities.

**7.10.1.4 Existing Exemption.** The requirements of 7.10.1.3 shall not apply to existing buildings, provided that the occupancy classification does not change.

### 7.10.1.5 Exit Access.

**7.10.1.5.1** Access to exits shall be marked by approved, readily visible signs in all cases where the exit or way to reach the exit is not readily apparent to the occupants.

**7.10.1.5.2\*** New sign placement shall be such that no point in an exit access corridor is in excess of the rated viewing distance or 100 ft (30 m), whichever is less, from the nearest sign.

## Life Safety Code

**7.10.1.6\*** Floor Proximity Exit Signs. Where floor proximity Exit Signs are required in Chapters 11 through 43, such signs shall comply with 7.10.3, 7.10.4, 7.10.5, and 7.10.6 for externally illuminated signs and 7.10.7 for internally illuminated signs. Such signs shall be located near the floor level in addition to those signs required for doors or corridors. The bottom of the sign shall be not less than 6 in. (150 mm), but not more than 18 in. (455 mm), above the floor. For exit doors, the sign shall be mounted on the door or adjacent to the door, with the nearest edge of the sign within 4 in. (100 mm) of the door frame.

**7.10.1.7\*** Floor Proximity Egress Path Marking. Where floor proximity egress path marking is required in Chapters 11 through 43, an approved floor proximity egress path marking system that is internally illuminated shall be installed within 18 in. (455 mm) of the floor. Floor proximity egress path marking systems shall be listed in accordance with ANSI/UL 1994, Standard for Luminous Egress Path Marking Systems. The system shall provide a visible delineation of the path of travel along the designated exit access and shall be essentially continuous, except as interrupted by doorways, hallways, corridors, or other such architectural features. The system shall operate continuously or at any time the building fire alarm system is activated. The activation, duration, and continuity of operation of the system shall be in accordance with 7.9.2. The system shall be maintained in accordance with the product manufacturing listing.

**7.10.1.8\* Visibility.** Every sign required in Section 7.10 shall be located and of such size, distinctive color, and design that it is readily visible and shall provide contrast with decorations, interior finish, or other signs. No decorations, furnishings, or equipment that impairs visibility of a sign shall be permitted. No brightly illuminated sign (for other than exit purposes), display, or object in or near the line of vision of the required Exit Sign that could detract attention from the Exit Sign shall be permitted.

**7.10.1.9 Mounting Location.** The bottom of new egress markings shall be located at a vertical distance of not more than 6 ft 8 in. (2030 mm) above the top edge of the egress opening intended for designation by that marking. Egress markings shall be located at a horizontal distance of not more than the required width of the egress opening, as measured from the edge of the egress opening intended for designation by that marking to the nearest edge of the marking.

### 7.10.2 Directional Signs.

**7.10.2.1\*** A sign complying with 7.10.3, with a directional indicator showing the direction of travel, shall be placed in every location where the direction of travel to reach the nearest exit is not apparent.

**7.10.2.2** Directional Exit Signs shall be provided within horizontal components of the egress path within exit enclosures as required by 7.10.1.2.2.

**7.10.3\*** Sign Legend.

**7.10.3.1** Signs required by 7.10.1 and 7.10.2 shall read as follows in plainly legible letters, or other appropriate wording shall be used:

**EXIT**

**7.10.3.2\*** Where approved by the authority having jurisdiction, pictograms in compliance with NFPA 170, Standard for Fire Safety and Emergency Symbols, shall be permitted.

**7.10.4\*** Power Source. Where emergency lighting facilities are required by the applicable provisions of Chapters 11 through 43 for individual occupancies, the signs, other than approved self-luminous signs and listed photoluminescent signs in accordance with 7.10.7.2, shall be illuminated by the emergency lighting facilities. The level of illumination of the signs shall be in accordance with 7.10.6.3 or 7.10.7 for the required emergency lighting duration as specified in 7.9.2.1. However, the level of illumination shall be permitted to decline to 60 percent at the end of the emergency lighting duration.

### 7.10.5 Illumination of Signs.

**7.10.5.1\*** General. Every sign required by 7.10.1.2, 7.10.1.5, or 7.10.8.1, other than where operations or processes require low lighting levels, shall be suitably illuminated by a reliable light source. Externally and internally illuminated signs shall be legible in both the normal and emergency lighting mode.

#### 7.10.5.2\* Continuous Illumination.

**7.10.5.2.1** Every sign required to be illuminated by 7.10.6.3, 7.10.7, and 7.10.8.1 shall be continuously illuminated as required under the provisions of Section 7.8, unless otherwise provided in 7.10.5.2.2.

**7.10.5.2.2\*** Illumination for signs shall be permitted to flash on and off upon activation of the fire alarm system.

### 7.10.6 Externally Illuminated Signs.

#### 7.10.6.1\* Size of Signs.

**7.10.6.1.1** Externally illuminated signs required by 7.10.1 and 7.10.2, other than approved existing signs, unless otherwise provided in 7.10.6.1.2, shall read EXIT or shall use other appropriate wording in plainly legible letters sized as follows:

- (1) For new signs, the letters shall be not less than 6 in. (150 mm) high, with the principal strokes of letters not less than 3/4 in. (19 mm) wide.
- (2) For existing signs, the required wording shall be permitted to be in plainly legible letters not less than 4 in. (100 mm) high.
- (3) The word EXIT shall be in letters of a width not less than 2 in. (51 mm), except the letter I, and the minimum spacing between letters shall be not less than 3/8 in. (9.5 mm).
- (4) Sign legend elements larger than the minimum established in 7.10.6.1.1(1) through (3) shall use letter widths, strokes, and spacing in proportion to their height.

7.10.6.1.2 The requirements of 7.10.6.1.1 shall not apply to marking required by 7.10.1.3 and 7.10.1.7.

#### 7.10.6.2\* Size and Location of Directional Indicator.

**7.10.6.2.1 Directional indicators**, unless otherwise provided in 7.10.6.2.2, shall comply with all of the following:

- (1) The directional indicator shall be located outside of the EXIT legend, not less than 3/8 in. (9.5 mm) from any letter.
- (2) The directional indicator shall be of a chevron type, as shown in Figure 7.10.6.2.1.
- (3) The directional indicator shall be identifiable as a directional indicator at a distance of 40 ft (12 m).
- (4) A directional indicator larger than the minimum established for compliance with 7.10.6.2.1(3) shall be proportionately increased in height, width, and stroke.
- (5) The directional indicator shall be located at the end of the sign for the direction indicated.

## Life Safety Code



### 7.10.6.2.1 Chevron Type Indicator.

**7.10.6.2.2** The requirements of 7.10.6.2.1 shall not apply to approved existing signs.

**7.10.6.3\*** Level of Illumination. Externally illuminated signs shall be illuminated by not less than 5 ft-candles (54 lux) at the illuminated surface and shall have a contrast ratio of not less than 0.5.

### 7.10.7 Internally Illuminated Signs.

**7.10.7.1 Listing.** Internally illuminated signs shall be listed in accordance with ANSI/UL 924, Standard for Emergency Lighting and Power Equipment, unless they meet one of the following criteria:

- (1) They are approved existing signs.
- (2) They are existing signs having the required wording in legible letters not less than 4 in. (100 mm) high.
- (3) They are signs that are in accordance with 7.10.1.3 and 7.10.1.6.

**7.10.7.2\* Photoluminescent Signs.** The face of a photoluminescent sign shall be continually illuminated while the building is occupied. The illumination levels on the face of the photoluminescent sign shall be in accordance with its listing. The charging illumination shall be a reliable light source, as determined by the authority having jurisdiction. The charging light source, shall be of a type specified in the product markings.

### 7.10.8 Special Signs.

#### 7.10.8.1 Sign Illumination.

**7.10.8.1.1** Where required by other provisions of this Code, special signs shall be illuminated in accordance with 7.10.5, 7.10.6.3, and 7.10.7.

**7.10.8.1.2** Where emergency lighting facilities are required by the applicable provisions of Chapters 11 through 43, the required illumination of special signs shall additionally be provided under emergency lighting conditions.

**7.10.8.2** Characters. Special signs, where required by other provisions of this Code, shall comply with the visual character requirements of ICC/ANSI A117.1, American National Standard for Accessible and Usable Buildings and Facilities.

### 7.10.8.3\* No Exit.

**7.10.8.3.1** Any door, passage, or stairway that is neither an exit nor a way of exit access and that is located or arranged so that it is likely to be mistaken for an exit shall be identified by a sign that reads as follows:

**NO EXIT**

**7.10.8.3.2** The NO EXIT sign shall have the word NO in letters 2 in. (51 mm) high, with a stroke width of 3/8 in. (9.5 mm), and the word EXIT in letters 1 in. (25 mm) high, with the word EXIT below the word NO, unless such sign is an approved existing sign.

**7.10.8.4 Elevator Signs.** Elevators that are a part of a means of egress (see 7.2.13.1) shall have both of the following signs with a minimum letter height of 5/8 in. (16 mm) posted in every elevator lobby:

- (1) \*Signs that indicate that the elevator can be used for egress, including any restrictions on use
- (2) \*Signs that indicate the operational status of elevators

**7.10.8.5\* Evacuation Diagram.** Where a posted floor evacuation diagram is required in Chapters 11 through 43, floor evacuation diagrams reflecting the actual floor arrangement and exit locations shall be posted and oriented in a location and manner acceptable to the authority having jurisdiction.

### 7.10.9 Testing and Maintenance.

**7.10.9.1 Inspection.** Exit Signs shall be visually inspected for operation of the illumination sources at intervals not to exceed 30 days or shall be periodically monitored in accordance with 7.9.3.1.3.

**7.10.9.2 Testing.** Exit Signs connected to, or provided with, a battery-operated emergency illumination source, where required in 7.10.4, shall be tested and maintained in accordance with 7.9.3.

NFPA 101® Life Safety Code®  
2015 Edition

©2015, NFPA, All Right Reserved  
Life Safety Code® and NFPA 101® are registered trademarks of the National Fire Protection Association, Inc.

## Limited warranty

- 1.1 Lightalarms® 6, 12 and 24 volt Emergency Lighting Unit Equipment (excluding lamps and fuses) and Exit Signs are fully warranted to be free of defects in material and workmanship under normal use for a period of three years from date of installation (see Paragraph 2.1). (For MR16 LED light source, see Paragraph 3.3)
- 1.2 Lightalarms® 6, 12 and 24 volt Emergency Lighting Unit Equipment (excluding lamps and fuses) and Exit Signs listed below are fully warranted to be free of defects in material and workmanship under normal use for a period of five years from date of installation (see Paragraph 2.1). (For MR16 LED light source, see Paragraph 3.3)

Architectural	Commercial	Industrial	Remote
Camray™ LED Series	Grande™ Battery Series	Severe™ XV12E, XV24E Series	Camray™ LED Series
Phantom™ Series	Grande™ Combo Series	Severe™ XV, XVE Series	Phantom™ Series
Mini-Phantom™ Series	Grande™ Exit Series	Severe™ VH Series	Mini-Phantom™ Series
Simplicity™ SLED, SPLED Series Edge-Lit	Galaxy™ XD, XDN Die-Cast Series	Severe™ SVXH Series	SP High Performance Series
Genesis™ GX, GXE Series	Galaxy™ XDPC Series	Severe™ XVH, XVH12N, XVH12H Series	ELF650 Remote Series
Genesis™ Floor Proximity Series	Galaxy™ Slim TX, TXE Series	SP High Performance Series	SPRL Remote Series
TBR Battery series	Grande™ Compact Series	EXP6N & EXP12N Battery & Combo Series	ELF650 Remote Series
RD Battery series	Simplicity™ Economizer Series	X402 Exit Series	SPRL Remote Series
		EPF401 Series	
		SPHRL Remote Series	
		SPH Battery Series	

- 1.3 Lightalarms® 3.6 volt Emergency Lighting Unit Equipment (excluding lamps, and fuses) are fully warranted to be free of defects in material and workmanship under normal use for a period of three from date of installation (see Paragraph 2.1).
- 1.4 Lightalarms® 6, 12 and 24 volt Unit Equipment Batteries are warranted as follows (Warrant below includes the full warranty on entire unit as called out in Paragraph 1.1–1.3).

**\*Maximum Storage life. Must Be Recharged If Not Placed in Service Or Battery Warranty Void**

Battery type	Life expectancy	Shelf life*	Full warranty	Pro rata warranty
Sealed Lead-Calcium	8 years	6 months	3 years	3 years
High Temperature Lead-Calcium	8 years	6 months	5 years	3 years
Sealed Nickel-Cadmium	10 years	1 year	5 years	5 years
Nickel-Metal Hydride	10 years	1 year	5 years	5 years

- 2.1 The full warranty period begins on the date of installation or 90 days from date of shipment, whichever date is earlier.
- 2.2 Should a defect appear in the equipment or batteries listed in Paragraphs 1.1–1.4 above within the specified full warranty period, Lightalarms® will repair or replace equipment without charge (see Paragraph 3.3). Such repair or replacement shall be the purchaser's exclusive remedy.
- 2.3 The Pro Rata Warranty Period for batteries begins on the date the full warranty period ends.
- 2.4 A battery determined to be defective during the Pro Rata Warranty Period shall be repaired or replaced at a cost equal to the net price in effect at the time, reduced by the percentage obtained in multiplying 10% by the number of full years remaining in the total warranty period. Such repair or replacement at this adjusted price shall be the purchaser's exclusive remedy.
- 3.1 All warranties are subject to proper installation and maintenance in accordance with the instructions supplied.
- 3.2 Any material deemed defective must be returned, freight prepaid, to the factory for evaluation (see Paragraph 5.1–5.3). Any changes in circuitry or components by other than authorized Lightalarms® personnel or its service companies will void the warranty.
- 3.3 All warranties are limited to the repair and/or replacement or parts or equipment, which, upon examination at our plant, are determined to be defective and in our judgement are subject to repair or replacement under warranty. Replacement of lamps and fuses is not included in the warranty except for MR16 LED lamps are warranted to be free of defects in material and workmanship under normal use for a period of five (5) years when purchased and used with Lightalarms® Battery Units, Combination Units or Remotes. The full warranty period begins on the date of installation or ninety (90) days from the date of shipment, whichever date is earlier.
- 3.4 If new replacement parts are shipped before defective goods are received for evaluation, the replacement parts will be invoiced at the net price in effect at that time. These charges will be credited if, upon receipt and evaluation of goods, a defect is determined. Only replacement parts will be shipped under these circumstances, if field replacement is possible. Lightalarms® FACTORY ONLY RESERVES THE RIGHT TO SHIP NEW UNIT EQUIPMENT FOR REPLACEMENT PURPOSES. Units returned after installation cannot be restored to 100% saleable condition.
- 4.1 In no event shall Lightalarms® be liable for backcharges of any kind, including, without limitation, labor charges for field repair or late penalties.
- 4.2 This warranty does not cover damages caused by improper maintenance of installation or damage due to installation in areas with other than normal temperatures and environmental conditions per application specifications. Lightalarms® assumes no responsibility for any damage to people, property, apparatus or otherwise resulting from improper installation or maintenance of its Emergency Lighting Unit Equipment.
- 4.3 This warranty does not cover damages caused by abuse, fire or Act of God.
- 4.4 In no event shall Lightalarms® be liable for incidental or consequential damages.
- 4.5 The foregoing warranty is in lieu of all other warranties, expressed or implied, or merchantability, fitness for a particular purpose or any other thing. Except as stated in this warranty, Lightalarms® shall not be liable for any defects in, or breach of any contract relating to, the quality of performance of Lightalarms® Equipment under any theory of law including, without limitation, contract, negligence, strict liability or misrepresentation.
- 4.6 Lightalarms® warranty coverage shall not apply to any equipment of another manufacturer used in conjunction with Lightalarms® Equipment.
- 4.7 Some states do not allow limitation on how long an implied warranty lasts, so the above limitation may not apply to you. Some states do not allow the exclusion or limitation of incidental or consequential damages, so the above limitation or exclusion may not apply to you. This written warranty gives you specific legal rights and you may also have other rights which vary from state to state.
- 5.1 No returned defective materials will be accepted without a Returned Goods Authorization issued in writing by an authorized Lightalarms® employee.
- 5.2 Purchaser is responsible for secure packing of returned materials to provide best possible assurance against damage in shipment.
- 5.3 Defective batteries of any kind must not be returned to Lightalarms® factory without strict adherence to special instructions for handling and shipping. WARNING Never ship a refillable wet battery in any type of emergency lighting equipment. Failure to adhere to this policy will void warranty.
- 5.4 Defective goods returned to the factory must be shipped prepaid. COLLECT RETURNED SHIPMENT WILL BE REFUSED. Freight charges to return repaired equipment or ship replacement equipment to the purchaser to be paid by Lightalarms®. Factory will return repaired goods via same shipping method as received.

**FAILURE TO COMPLY WITH ANY OF THE STIPULATIONS SET FORTH WILL VOID THE WARRANTY. ANY EXCEPTIONS TO THE FOREGOING WARRANTY MUST BE REQUESTED AND ACCEPTED IN WRITING PRIOR TO SHIPMENT. LIGHTALARMS® EQUIPMENT NOT LISTED IN PARAGRAPHS 1.1–1.4 IS WARRANTED AS DESCRIBED ON ITS INDIVIDUAL DATA SHEET WITH THE STIPULATIONS AS STATED IN PARAGRAPHS 2.1–5.4.**

## Product index

Series	Page	Series	Page	Series	Page	Series	Page
12PMR2	128	GR624M	39	PG2	99	V12G1	103
24PMR2	128	GRA6	91	PH	75	V12G2	103
2XT	61	GRAN	37	PHG	75	V12G3	<b>103</b>
3FTC	176	GRN2	91	PT10	83	V12H1	<b>103</b>
3FTC3R	178	GX	27	PT18	83	V12N1	<b>103</b>
8SE	19	GXE	27	QLX500	40, 41	V12N2	103
8SEN	19	GXEM	25	QLXN500	40, 41	VG1	103
8SES	19	GXM	25	RD12C4	81	VH12G1	113
CAM	93, 131	IPS	172	RD12M3	81	VH12G2	113
CPS	185	LADL12	152	RD6M1	81	VH12G3	113
DR1130	132	LADL20-N	153	RP	71	VHG1	113
DR2130	132	LADL30-N	152	RPR	123	VRC	185
DR3130	132	LADL32	152	RSTH18R	127	WG1-L	186
ELF3	133	LADL7	152	RSTH19	127	WG10-L	187
ELF612	43, 45, 85, 135	LALDR	149, 151	RTS-0-10V-24V-L	167	WG11-L	187
ELF612D	43, 45, 85	LAXC	42	S12E5	101	WG12-L	187
ELF640	136	LCA	87, 117	S12E6	101	WG13-L	187
ELF640D	136	LCAB	85	S24E4	101	WG14-L	187
ELF640P	136	LCAC	45	SAF-2	129	WG15-L	187
ELF640PD	136	LCAR	45, 85, 134	SE	17	WG2-1	186
ELF650	137	LMILC	163	SEN	17	WG3-L	186
ELF650D	137	LMIU	165, 167	SES	17	WG4-L	186
ELF650P	137	LSCN	73, 125	SLEDN	15	WG5-L	186
ELF650PD	137	M12G1	97	SP12	105	WG6-L	186
ELF651	141	M12G1SP	95	SP12G3	105	WG8-L	186
ELF651D	141	M12N1	97	SP12G6	105	X402	57
ELF652	47, 87	M12N1SP	95	SP12N4	105	XD21	29
EPC-2-D-L	158	M12N2	97	SP24N9	105	XD22	29
EPC-2-FM-D-L	156	M12N2SP	95	SPH12G3	109	XDA	29
EPC-2-FM-L	156	MB	185	SPH12G6	109	XDC	29
EPC-2-L	158	MG1	97	SPH12N4	109	XDN	29
EPF401	143	MG18	97	SPH24N9	109	XDNEX	29
EXP	59, 115	MGR12A1	89	SPHRL	111	XDNEXRF	29
FPGXLD	25	MGR12H1	89	SPLLEDN	15	XDPC	31
FTC	174	MGR12H2	89	SPRL	107, 139	XLD	33
FTC3R	178	MGRA1	89	T12BRCO	79	XLED	33
FTCM	170	MGRA12A2	89	T12RBC2	79	XT	61
GR1224H	39	MGRH1	89	TBRCO	79	XV	49
GR1224M	39	MP	185	TS	57	XV12E	51
GR1240H	39	MPH	77	TX	32	XV24E	51
GR1250H	39	MPHG	77	TXE	32	XVE	49
GR12A4	91	P12G1	99	UEA	21	XVEHZ	53
GR12A7	91	P12Q1	99	UEN	21, 23	XVH	55
GR12N4	91	P12Q2	99	UQLXN500	47	XVH12N	55
GR612H	39	PG1	99	UX4	35	XVHZ	53
GR612M	39						









# Lightalarms

Inside Sales | Customer Support

Tel : 1-888-935-3610

Fax: 1-888-867-1566

Technical Support

Tel : 1-888-552-6467

Fax: 1-800-316-4515

[lightalarms.com](http://lightalarms.com)

---

**by ABB**

All information and specifications contained in this catalog are subject to change due to engineer design, errors and omissions.  
Illustrations and diagrams within this catalog may vary from actual products.

© 2021 ABB. All rights reserved.  
Order no. LACONDCAT-US

